



## SEL-551 Overcurrent/Reclosing Relay

# Distribution Protection and Control



*Distribution protection and control for new installations and retrofits.*

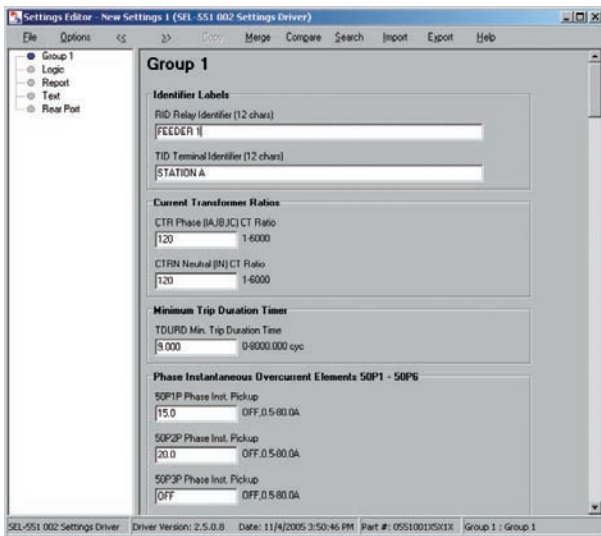

Develop settings using acSELEATOR® QuickSet™ SEL-5030 Software.

## Features and Benefits

### ■ Complete Overcurrent Protection

Protect lines and equipment using a sensitive and secure mix of phase, negative-sequence, and ground overcurrent elements. Have complete ground fault protection with residual ground and neutral ground overcurrent elements. Provide high-speed operation, even with severe CT saturation, using the SEL Adaptive Overcurrent Element.

### ■ Multishot Reclosing With Sequence Coordination

Program up to a four-shot reclose sequence with reclose initiate supervision, skip-shot sequencing, and stall-open interval timing.

### ■ Integration

Integrate into industrial protection and control schemes with Modbus® RTU protocol. Order the serial communications port as either EIA-232 or EIA-485.

### ■ Field-Proven With Robust I/O

Program the two inputs and five outputs to meet your application needs using SELogic® control equations. A wide operating temperature range (-40° to +85°C) allows for installation in a control building or outdoor enclosure. Hardware options of high-current interrupting output contacts and plug-in connectors provide high reliability and ease of installation/removal.

### ■ Programmable Logic and Local/Remote Controls

Use acSELEATOR® QuickSet™ SEL-5030 Software to configure traditional or advanced protection and control schemes. Quickly make logic changes or improvements without rewiring. Use the front panel or serial port to actuate separate control switches.

***Making Electric Power Safer, More Reliable, and More Economical®***

# SEL-551 Overcurrent/Reclosing Relay

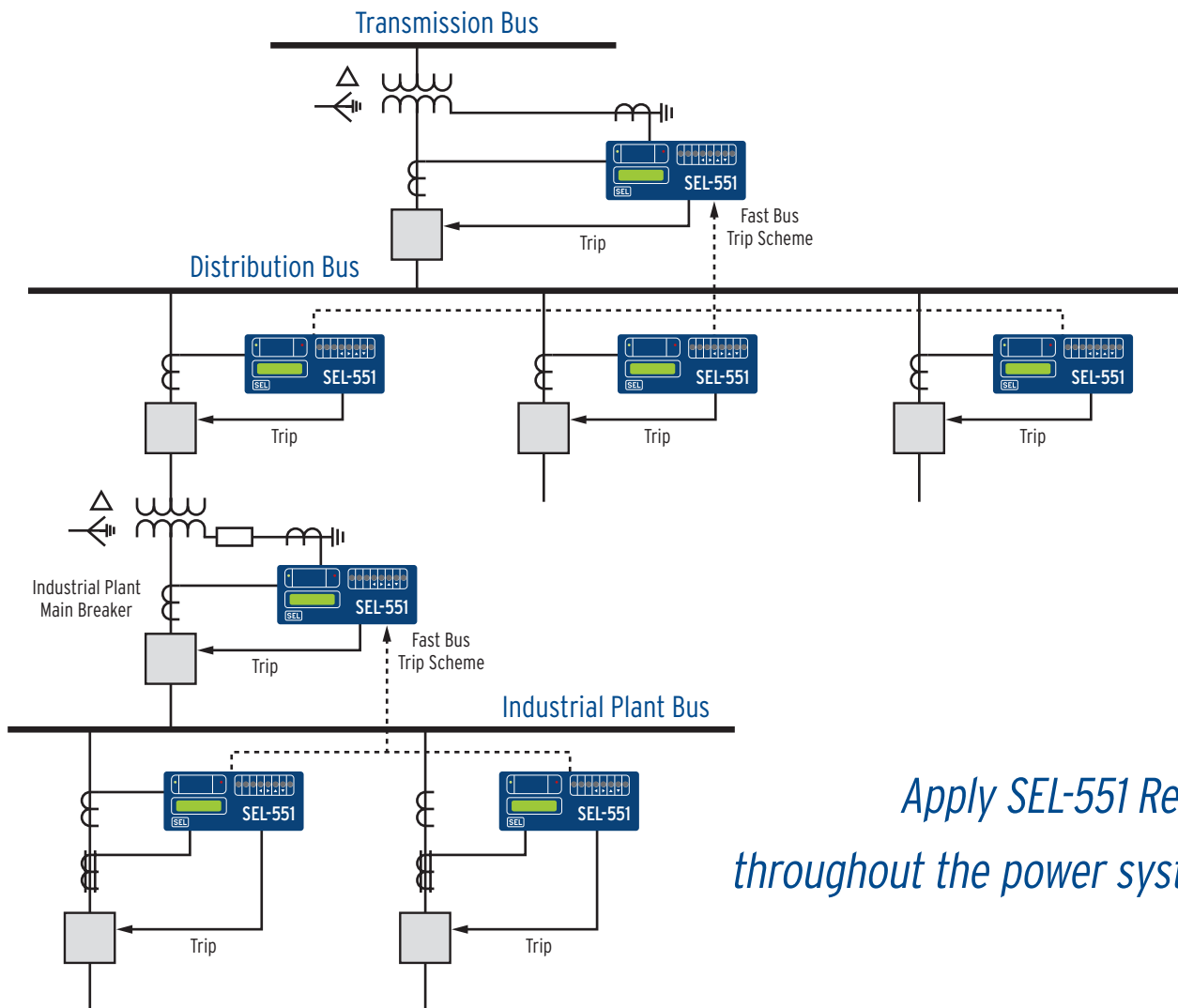

*Apply SEL-551 Relays  
throughout the power system.*

## Windows®-Based Graphical User Interface

- Save engineering time while keeping flexibility. Communicate with the SEL-551 Overcurrent/Reclosing Relay through any ASCII terminal, or use the acSELEATOR QuickSet Software graphical user interface.
- Develop settings offline with a menu-driven interface and completely documented help screens. Speed installation by copying existing settings files and modifying application-specific items.
- Simplify the settings procedure with rules-based architecture to automatically check interrelated settings. The software highlights out-of-range or conflicting settings for correction.
- Transfer settings files using a PC communications link with the SEL-551 Overcurrent/Reclosing Relay.



Pullman, Washington USA  
Tel: +1.509.332.1890 • Fax: +1.509.332.7990 • [www.selinc.com](http://www.selinc.com) • [info@selinc.com](mailto:info@selinc.com)

© 2000-2003, 2008 by Schweitzer Engineering Laboratories, Inc. PF00037 • 20080212

