

SEL-501 Dual Universal Overcurrent Relay

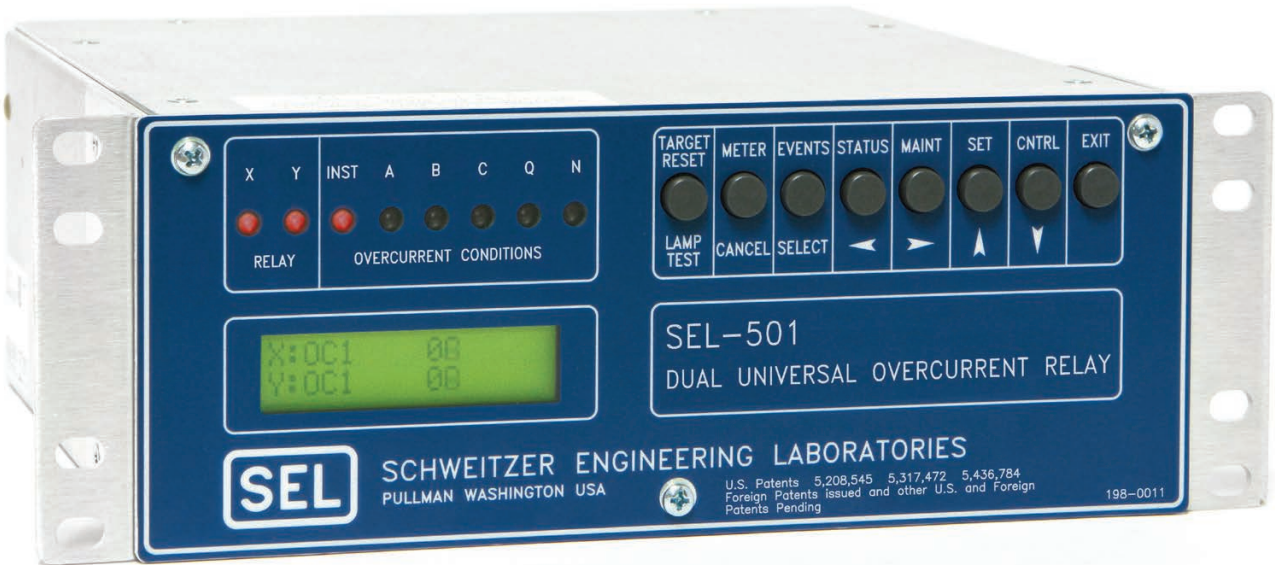

Dual Relays in a Single, Compact Package



Two complete and independent groups of protection in one low-cost unit.

Features and Benefits

Protection for Feeders, Buses, Transformers, Motors, and Breakers

Use preconfigured applications settings to simplify system installation. The SEL Adaptive Overcurrent Element provides high-speed operation, even in cases with severe CT saturation.

Patented Motor Thermal Modeling

Set using basic motor nameplate data to quickly implement complete thermal motor protection.

Control System Integration

Interconnect with automated control networks using the Modbus® RTU protocol. Select either an EIA-232 or EIA-485 serial communications port.

Easy Connections

Select either terminal block or plug-in Connectorized® terminations to speed up panel installation.

Field-Proven Hardware

Install the SEL-501 in a control house or outdoor enclosure with a wide operating temperature range (-40° to +85°C) for increased reliability.

Making Electric Power Safer, More Reliable, and More Economical®

Dual Relay Concept

The SEL-501 Dual Universal Overcurrent Relay provides two complete and independent groups of protection functions in one compact unit. The unit contains Relay X and Relay Y, each having separate optoisolated inputs, output contacts, and three-phase current inputs.

	Input	Output Contacts	Current Inputs
Relay X	XIN	XOUT1, XOUT2	IAX, IBX, ICX
Relay Y	YIN	YOUT1, YOUT2	IAY, IBY, ICY

Select the relay functions independently for Relays X and Y. Choose from five relay functions.

Five Relay Functions

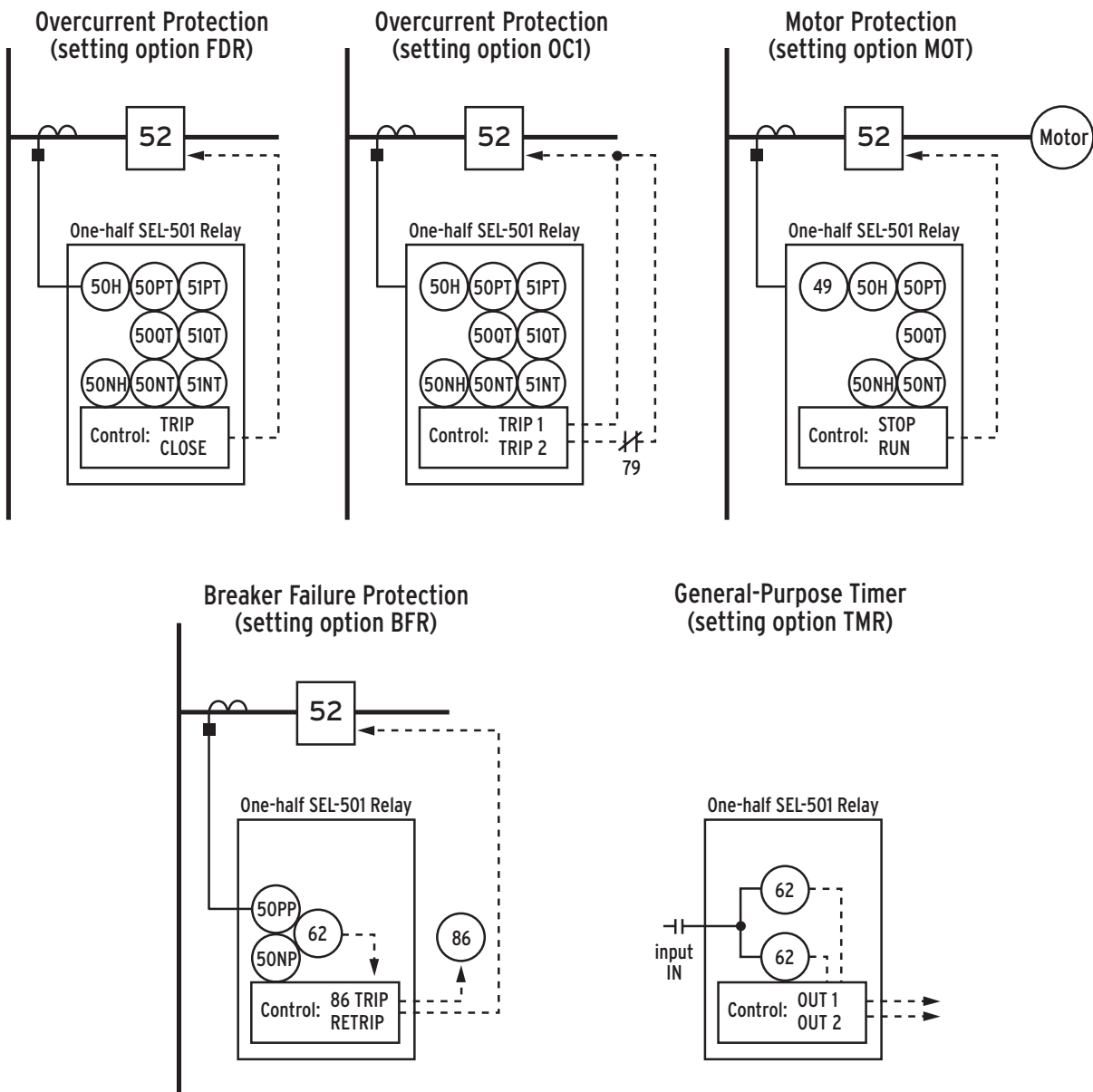

Motor Protection Elements

Elements	Instantaneous	Definite-Time
Phase (I _a , I _b , I _c)	50H	50PT
Negative-Sequence		50QT
Residual (I _R =I _a +I _b +I _c)	50NH	50NT
Ranges (A secondary)		
5 A Model	0.5–80 A	0.5–80 A
1 A Model	0.1–16 A	0.1–16 A
Timing		0–16,000 Cycles

Thermal Model (49) provides locked-rotor, unbalance, and overload protection.

Motor operation monitors include load-jam trip, load-loss trip, and starts-per-hour limit.

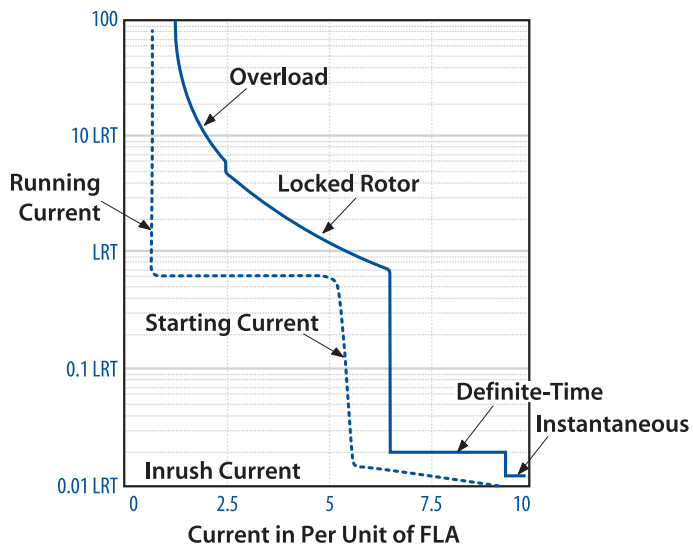

Motor characteristics plotted with motor starting current.

Additional Motor Protection Features

Unbalance Protection

Protection for motor unbalance current is provided in two ways. First, the motor thermal model accounts for the added heating caused by negative-sequence current. The relay automatically accounts for these effects during overload and starting conditions. Additionally, the relay offers a definite-time negative-sequence overcurrent element for tripping during single-phasing or other very high unbalance conditions.

Load-Jam and Load-Loss Tripping

A definite-time undercurrent function provides tripping on loss of load. Definite-time overcurrent load-jam function protects the motor during these conditions. Both functions are only enabled while the motor is running, alleviating motor start coordination concerns.

Starts-Per-Hour Limit

The relay detects starts and trips if a start exceeds a settable limit for starts within the past 60 minutes.

General Specifications

AC Input Currents

I_N: 1 A or 5 A nominal; 3 · I_N continuous; 100 · I_N for 1 second; measurement linear to 20 · I_N, symmetrical. 60 Hz and 50 Hz models available.

Output Contacts

30 A make per IEEE C37.90-1989
 6 A carry; MOV protected
 100 A for one second
 270 Vac/360 Vdc MOV for differential surge protection

Logic Input Ratings

Field selectable: 24 Vdc, 48 Vdc, 125 Vdc, 250 Vdc (in conventional terminal block version). Contact SEL for logic input ratings in Connectorized version.

Power Supply Ratings

24 Volt 16–36 Vdc
 48/125 Volt 36–200 Vdc or 85–140 Vac
 125/250 Volt 85–350 Vdc or 85–264 Vac
 3.5 watts nominal, 5.5 watts maximum

EIA-232 or EIA-485 Serial Communications

Rear-panel, 9-pin, sub-D connector; 300, 1200, 2400, 4800, 9600, 19200, and 38400 bps; settable bps rate and data bit protocols.

Protocols

ASCII
 Distributed Port Switch Protocol (LMD)
 Modbus RTU
 SY/MAX (only available in SEL-501-1 Relay)

Metering Functions

Instantaneous and demand ammetering functions
 Measurement accuracy: ±2% at nominal input

Operating Temperature

–40° to +85°C (–40° to +185°F)

SEL-501 Dual Universal Overcurrent Relay

Rear Panel

All screws are size #6-32. This relay is also available in a Connectorized version.

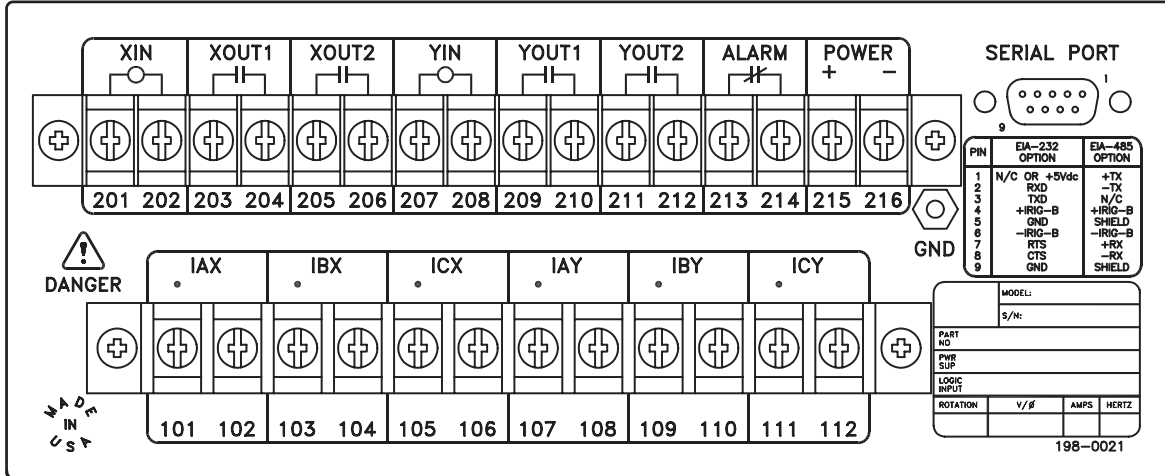

SEL-501 Relay Dimensions, Panel Cutout, and Drill Plan

19-inch rack-mounting options (see instruction manual):

- Two relays side by side
- One relay with a side mounting plate

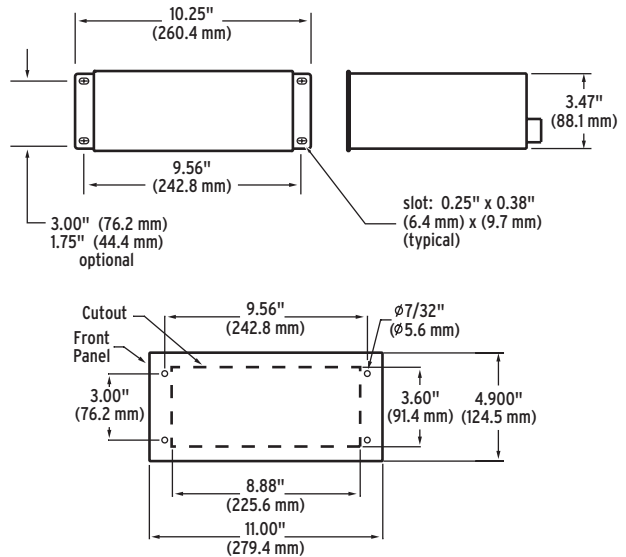
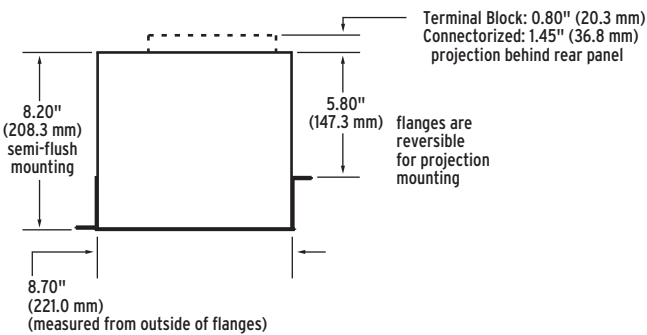

Pullman, Washington USA
Tel: +1.509.332.1890 • Fax: +1.509.332.7990 • www.selinc.com • info@selinc.com

© 2003–2012 by Schweitzer Engineering Laboratories, Inc. PF00035 • 20121112

