

SEL-487B

Bus Differential and Breaker Failure Relay



Advanced bus protection with built-in breaker failure detection

- Protect busbars with up to 21 terminals using high-speed, low-impedance bus differential elements.
- Implement distributed bus protection and simplify copper wiring using Time-Domain Link (TiDL™) technology.
- Improve system testing and post-fault analysis with comprehensive monitoring, metering, and event recording capabilities.



Functional Overview

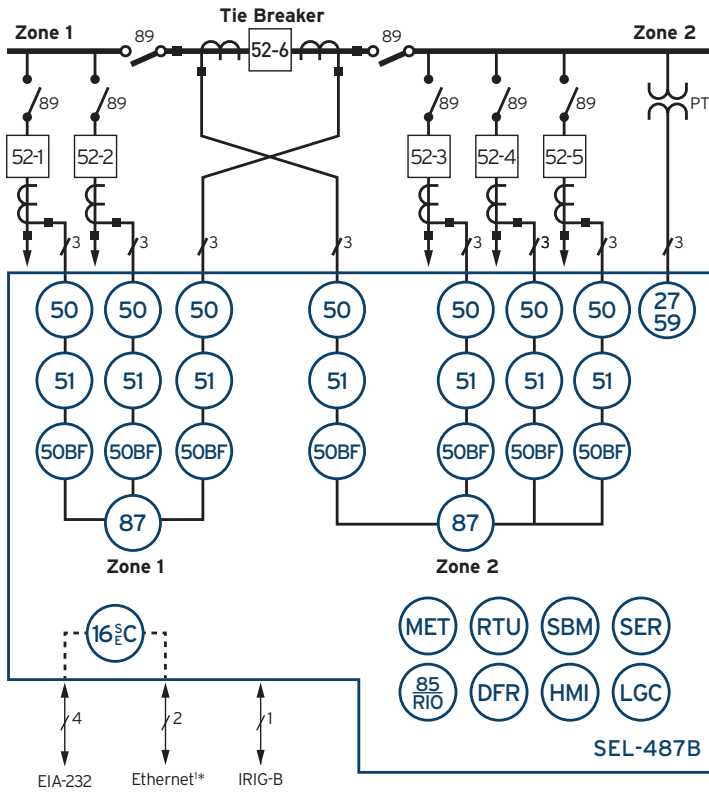

ANSI Number/Acronyms and Functions

16 SEC	Access Security (Serial, Ethernet)
27/59	Over-/Undervoltage
50	Overcurrent
50BF	Breaker Failure Overcurrent
51	Time-Overcurrent
85 RIO	SEL MIRRORED BITS® Communications
87	Current Differential
DFR	Event Reports
HMI	Operator Interface
LGC	Expanded SELogic® Control Equations
MET	High-Accuracy Metering
RTU	Remote Terminal Unit
SER	Sequential Events Recorder

Additional Functions

SBM	Station Battery Monitor
TiDL	Time-Domain Link Technology*

¹Copper or fiber-optic *Optional feature



Key Features

Low-Impedance Bus Differential Protection

The SEL-487B Bus Differential and Breaker Failure Relay protects bus systems with up to 21 terminals (21 CTs per relay, 63 CTs with a three-relay scheme), 6 protection zones, and 3 independent check zones. To optimize protection security, each check zone supervises a designated phase in the system and a patented open-CT detection algorithm blocks potential misoperations during open- or shorted-CT conditions. Differential and directional current elements provide increased security and fast fault detection. You can also reduce protection costs with built-in breaker failure protection.

Flexibility

Implement different ratio CTs and nondedicated CTs with the SEL-487B. The flexibility built into the settings allows you to eliminate complex wiring by using CT ratios that differ by up to a factor of 10:1. Take advantage of the same CTs for differential protection, metering, backup relaying, and other functions.

TiDL Technology

Modernize your substation by applying the TiDL-enabled SEL-487B with SEL-2240 Axion® TiDL nodes. This simple and secure digital secondary system solution is easy to implement, with no external time source or network engineering required. Replacing copper wires with fiber-optic cables increases safety, reduces costs associated with using copper wires, and limits the impact of electromagnetic interference.

Distributed Bus Protection

Apply the SEL-487B in a distributed bus protection scheme using TiDL technology. In a TiDL system, the Axion TiDL node is located out in the yard and acts as a field module. It digitizes analog signals and transports the data over a point-to-point fiber-optic cable to the TiDL-enabled SEL-487B located in the control house. The Axion's modular architecture allows you to select the number of analog, digital input, and digital output modules to match the application. The settings in the TiDL-enabled SEL-487B are the same as those in the standard SEL-487B, providing consistency and simplicity in commissioning.

Monitoring and Metering

The SEL-487B provides accurate, timely monitoring and metering of busbar, feeder, and substation signals. Terminal currents, breaker and disconnect positions, station dc voltage levels, and three-phase voltage are continuously monitored and updated. The relay also provides event reports and Sequential Events Recorder (SER) reports to simplify post-fault event analysis.



Product Overview

EIA-232 front serial port is quick and convenient for system setup and local access.

LCD automatically scrolls between custom displays.



Easy-to-use keypad aids simple navigation.

Front-panel LEDs indicate custom alarms and provide fast and simple information to assist dispatchers and line crews with rapid power restoration.



Programmable operator pushbuttons with user-configurable labels allow front-panel customization.

Choose from a horizontal panel-mount or rack-mount chassis and different size options.

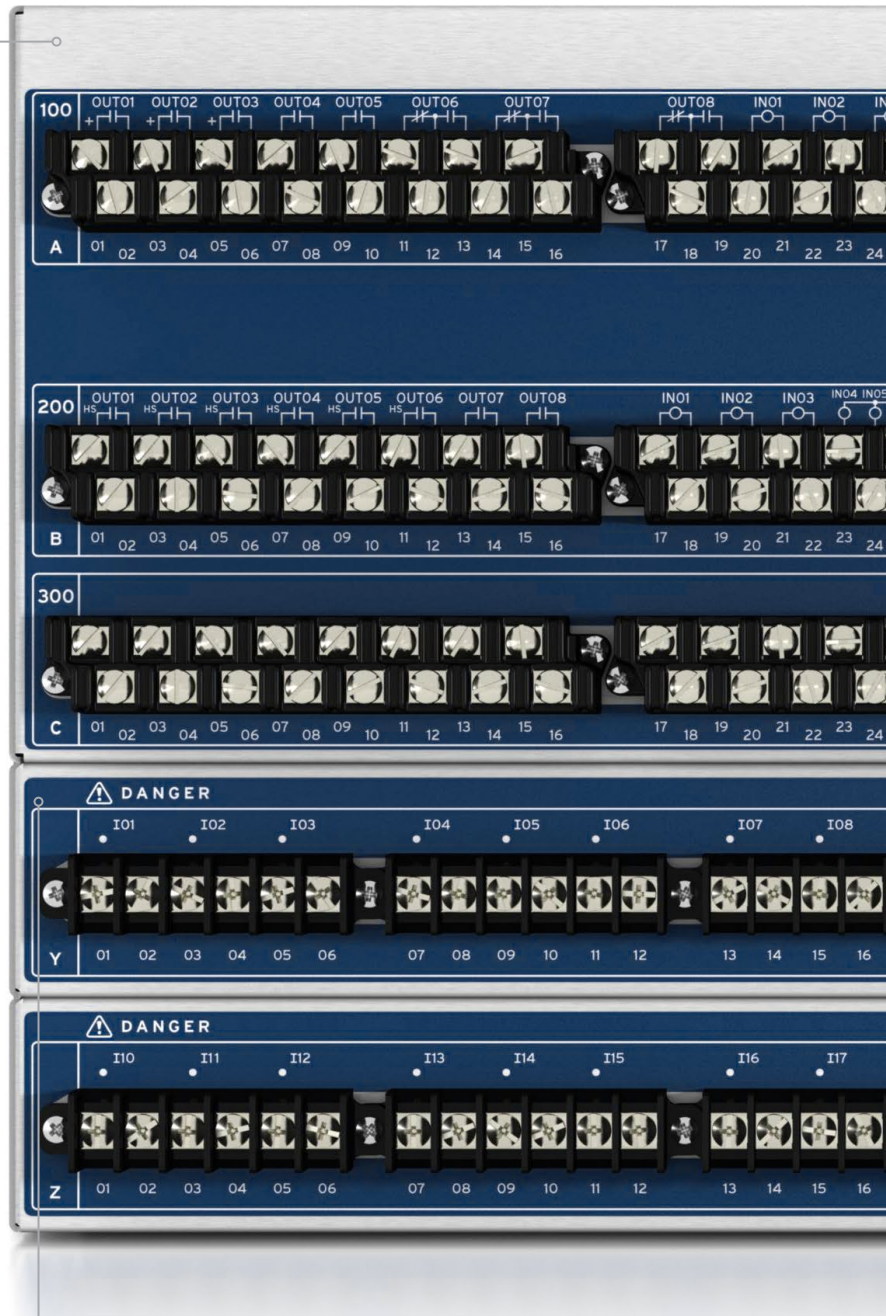

21 current and 3 voltage channels accommodate different busbar configurations.

Use one front and three rear EIA-232 ports for MIRRORRED BITS communications, DNP3, SCADA, and engineering access.



Communications protocols include FTP, Telnet, DNP3 LAN/WAN, the Parallel Redundancy Protocol (PRP), the IEEE 1588 Precision Time Protocol Version 2 (PTPv2),** and IEC 61850 Edition 2.*

Choose from power supply options such as 24–48 Vdc; 48–125 Vdc or 110–120 Vac; or 125–250 Vdc or 110–240 Vac.

*Optional

**For PTP implementation, Ports 5A and 5B must be ordered as an option.

Product Overview—TiDL Option

4U chassis with horizontal mounting options (panel or rack) accommodates your application needs.

Commission button usage prompts the relay to communicate with the Axion TiDL nodes.

LEDs indicate a valid configuration and successful commissioning.



LEDs indicate the connection status to a remote Axion TiDL node on a per-port basis.

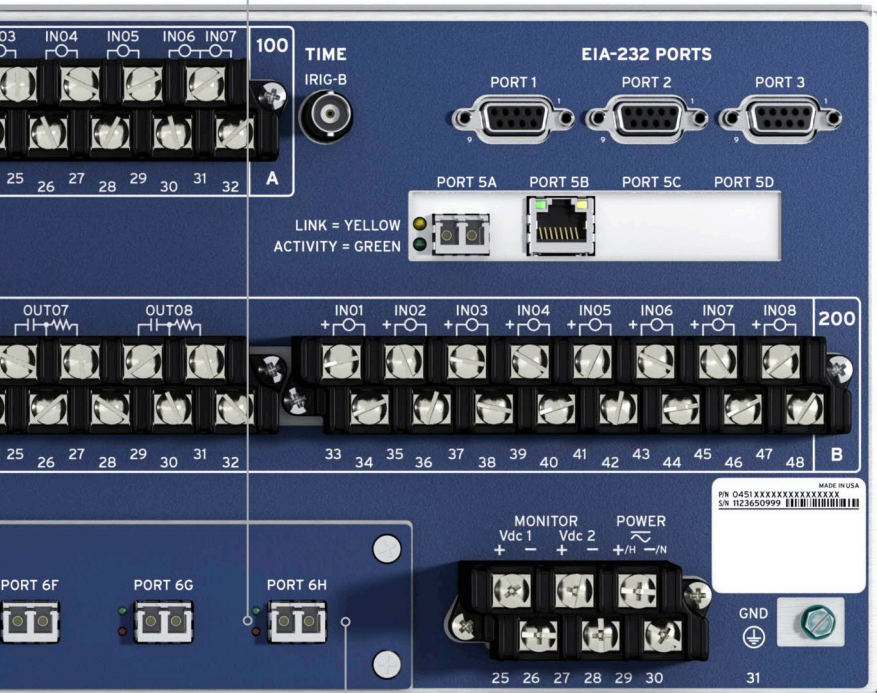

Eight 100 Mbps fiber-optic ports allow the TiDL-enabled relay to connect with eight remote Axion TiDL nodes and to receive remote analog and digital data.

Applications

Differential Protection

The SEL-487B includes six independent current differential elements, and each one provides:

- Fast operate times for all busbar faults.
- Security for external faults with heavy CT saturation.
- Security with subsidence current present.
- High sensitivity to busbar faults.
- Minimum delay for faults evolving from external to internal.

CT Supervision

For each zone, sensitive current differential elements detect differential current resulting from a differential

element that is not well-balanced (i.e., has wrong CT ratios). If the conditions persist for longer than a user-specified delay, the element asserts an alarm that you can use to generate an external alarm and/or block the zone.

Advanced Open-CT Detection Logic

The patented open-CT detection logic improves the security of the current differential element. It ensures current differential bus zones will not misoperate due to terminals that cannot be properly measured. This advanced logic blocks differential element misoperations that occur under open- or shorted-CT conditions. The open-CT detection logic monitors the CT terminals in every bus zone to detect when a contributing CT fails.

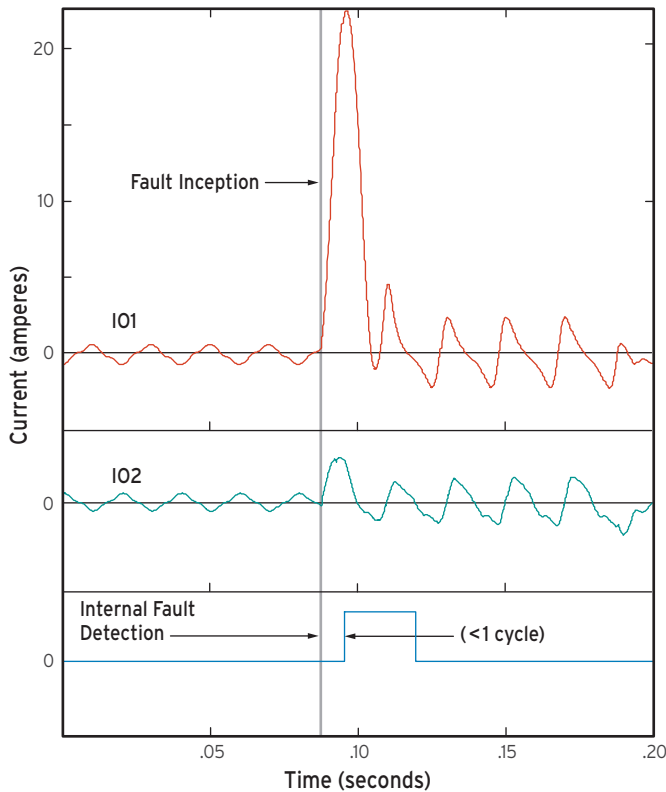

Differential element operates in less than one cycle for internal faults.

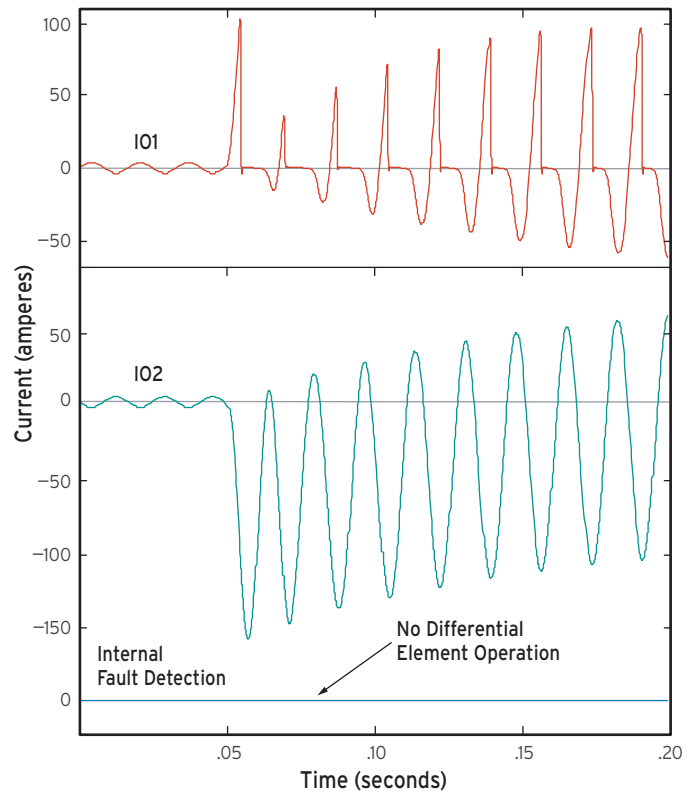

Differential element remains secure for external faults with heavy CT saturation.

Voltage Elements

Supervise current differential tripping within the relay by using voltage elements. Three separate voltage elements consist of two levels of phase under- and overvoltage elements and two levels of negative- and zero-sequence overvoltage elements for each of the three analog voltage quantities measured.

Integrated Overcurrent Protection

Ten overcurrent curves are available for each current input. Each torque-controlled time-overcurrent element has two reset characteristics. There is also one level of instantaneous and definite-time elements available for each current input.

Breaker Failure Detection

The SEL-487B includes complete breaker failure protection, with retrip capability for each terminal. Internal breaker failure is determined by predefined protection schemes that allow different types of trip signals and current flow conditions. You can set any terminal to either internal or external breaker failure protection; the inputs can provide individual or identical responses to each breaker failure condition.

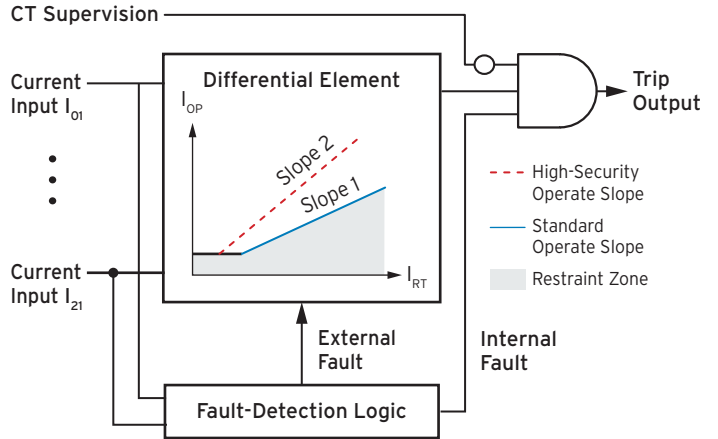

When the relay directional elements detect an external fault, the relay enters a high-security mode and dynamically selects a higher slope for the differential elements, making them more secure during the fault.

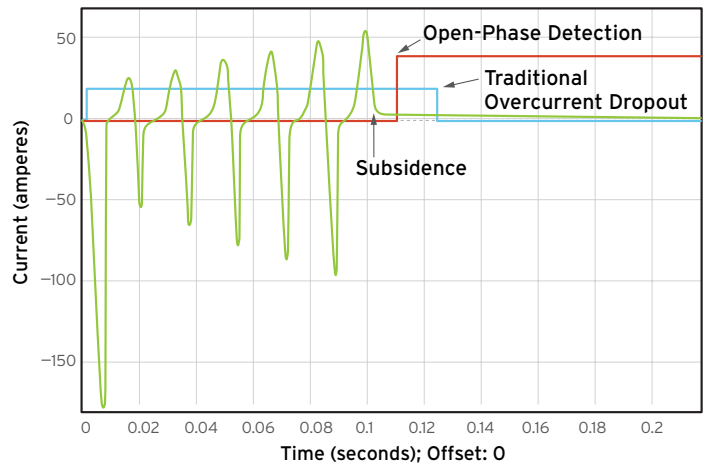

High-speed open-pole detection logic detects open-pole conditions in fewer than 0.75 cycles to reduce breaker failure coordination times.

Dynamic Zone Configuration

The SEL-487B dynamically assigns the input currents to the correct differential elements without the need for additional auxiliary relays. Connect the digital inputs from the busbar disconnect and breaker auxiliary contacts directly to the relay. SELogic control equations and zone selection logic will correctly assign the currents to the differential elements, even for complex bus arrangements (see top example).

Note that the SEL-487B automatically includes the Zone 4 currents in Zone 3 when disconnect switch DS3 is closed (see middle example).

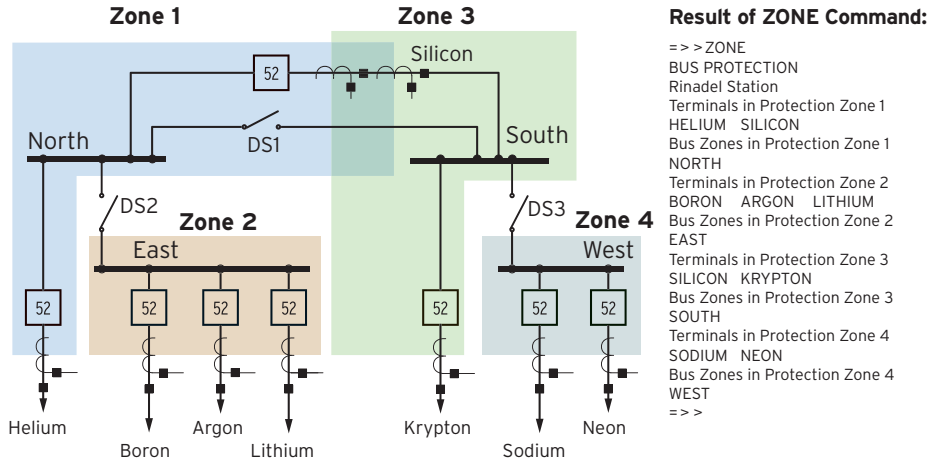

Three Independent Check Zones Supervise up to Six Differential Bus Zones

In complex busbar layouts, the SEL-487B uses disconnect auxiliary contact status to define current differential bus zones and supervises these zones on a per-phase basis with the independent "check zone" feature to prevent misoperation due to a discrepancy.

The check zone feature:

- Allows you to create your own custom applications using powerful SELogic control equations.
- Provides secure supervision for bus zones.
- Supervises bus zones on a per-phase basis, independent of the terminal auxiliary disconnect status.
- Processes its logic independently of all bus zones.
- Fits a wide variety of applications and protection philosophies, with independent pickup and slope settings.

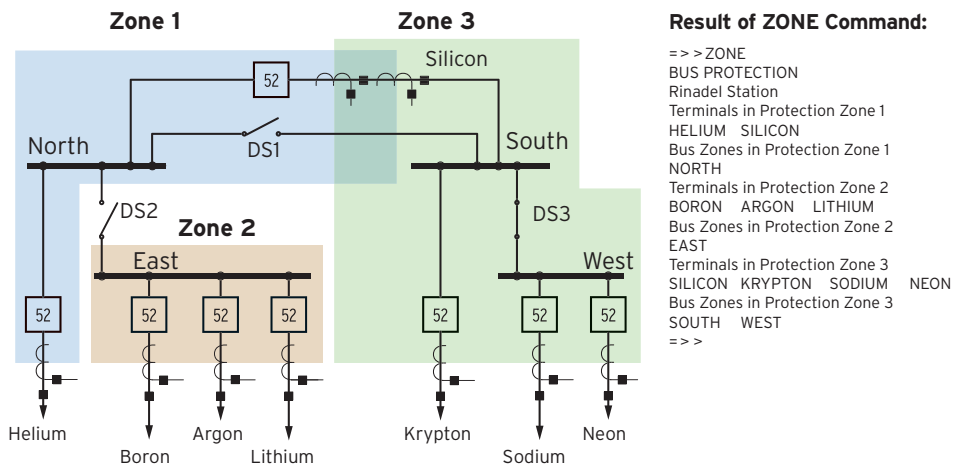

Three-Relay Bus Protection Application—For up to 21 Terminals

You can configure a check zone for every phase, encompassing all terminals at the station (except bus coupler and sectionalizing breakers), independent of the disconnect auxiliary contact status.

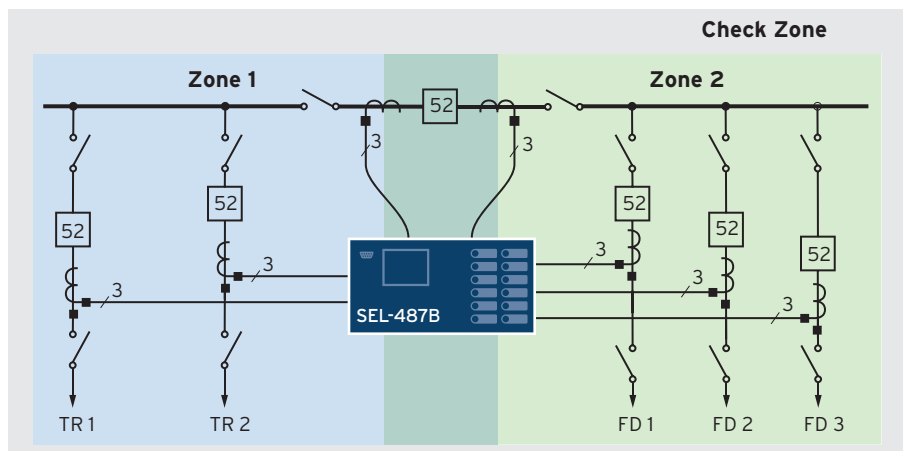

This example shows a single SEL-487B protecting a system with two 3-phase bus zones and increasing security by applying a check zone per phase.

Distributed Bus Protection Using TiDL Technology

SEL TiDL technology provides a simple and secure solution, enabling you to:

- Eliminate complexity—no network engineering or external time reference is required.
- Achieve strong cybersecurity by using point-to-point fiber connections, an isolated network, and no Ethernet switches.
- Implement state-of-the-art protection using the familiar SEL-487B settings and protection schemes.

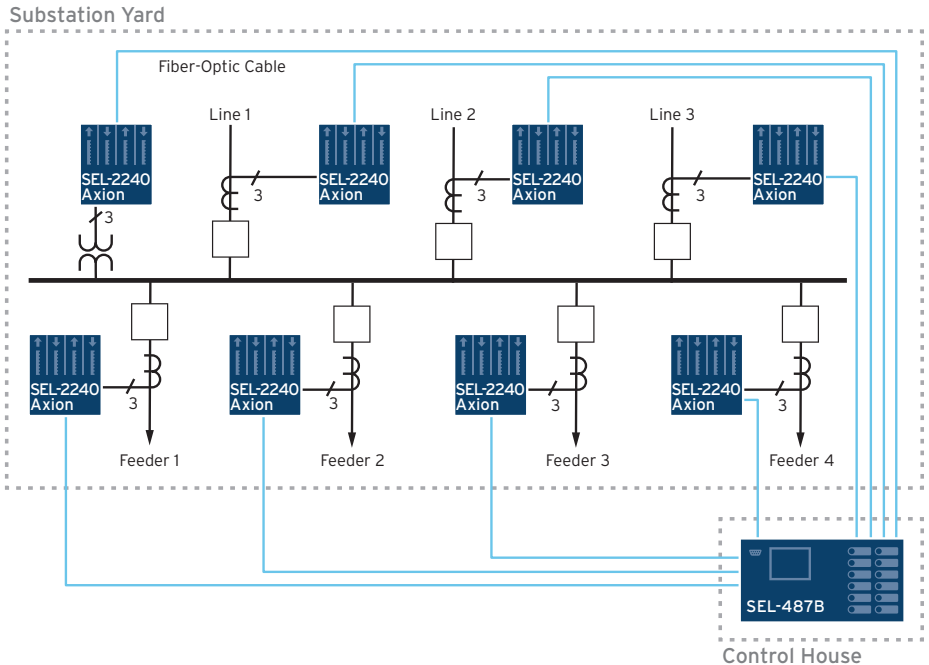

Automation and Control

With 32 local control points, the SEL-487B helps eliminate traditional panel control switches. You can set, clear, or pulse local control points with the programmable front-panel pushbuttons and display. Using SELoGic control equations, you can program the local control points to implement your control scheme.

The 32 remote control points help eliminate remote terminal unit (RTU)-to-relay wiring. Using serial port commands, you can set, clear, or pulse remote control points. You can also incorporate the remote control points into your control scheme via SELoGic control equations and apply remote control points for SCADA-type control operations, such as trip and group selection.

The SEL-487B control logic can replace the following:

- Traditional panel control switches
- RTU-to-relay wiring
- Traditional latching relays
- Traditional indicating panel lights
- Panel meters

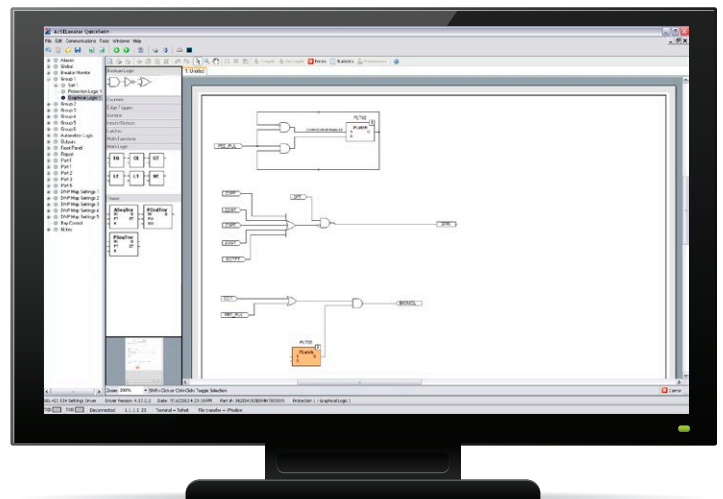

Simplified System Setup

Develop SEL-487B settings and busbar configurations offline with ACSELERATOR QuickSet® SEL-5030 Software. The system automatically checks interrelated settings and highlights out-of-range settings. You can transfer settings created offline to the SEL-487B by using a PC communications link.

The GLE in QuickSet simplifies the process of configuring your SEL-487B. With the GLE, you can view SELoGic equations graphically, making it easier to document settings files for validation and commissioning. You can also convert existing SELoGic control equations to easy-to-read diagrams and save diagrams with your QuickSet settings.

Accessibility and Communications

Simplify System Testing and Post-Fault Analysis

The SEL-487B event-reporting capabilities help improve understanding of even the most complex protective scheme operations. With the oscillographic and binary COMTRADE event reports and SER reporting in the SEL-487B, you can eliminate the need for external recorders or meters.

View SER Records

Gain a broad perspective of relay element operation with the SER in the SEL-487B. Items that trigger an SER entry are selectable and can include as many as 250 monitoring points, such as input/output change of state or element pickup/dropout. The relay SER stores the latest 1,000 events, which are available through the SER command. The latest 200 events are also viewable via the front-panel LCD.



SEL-5601-2 SYNCHROWAVE® Event Software provides powerful analytic capabilities.

Access Useful Information

The SEL-487B makes it easy to access useful information when and where you need it.

- Metering quantities include primary and secondary voltage and current magnitudes as well as angles for each terminal.
- Zone information displays the primary or secondary current and voltage for each terminal. The polarity of each CT and the bus zones in each of the protective zones at the station are also included.
- Differential metering shows the operating and restraint currents for each zone as well as the reference current.
- Battery monitoring provides warning and alarm thresholds that you can monitor with the SEL-2032 Communications Processor and the SEL-3530 Real-Time Automation Controller (RTAC). You can also set up the system to send status messages to a local display, phones, or other devices.



SYNCHROWAVE Event displays individual operate and restraint currents for three different protection zones.

Integrate the SEL-487B With Ethernet Networks

You can apply SEL-487B Relays with Ethernet directly to a local network or through an SEL communications processor.

- Use DNP3 LAN/WAN or Modbus® TCP to quickly send information through your networks.
- Provide information to the right people for improved system performance.
- Transfer data with high-speed Ethernet for fast HMI updates and file uploads.
- Use popular Telnet applications for easy terminal communication with SEL relays and other devices.
- Combine IEC 61850 Edition 2 technology, an Ethernet network, and the SEL-487B for the fastest overall performance of IEC 61850 relays for substation automation and control.
- Access basic relay information on a standard Ethernet network with the built-in web server. You can view the relay status, SER reports, metering information, and settings. Web server access requires the relay password and is limited to read-only viewing of information.
- Simplify wiring and installation by receiving a time signal over existing Ethernet networks. The Simple Network Time Protocol (SNTP) makes a good backup to more accurate IRIG-B time synchronization, or you can use optional high-accuracy PTPv2 in place of IRIG-B.
- Support seamless failover for Ethernet communications with PRP, which allows communications network redundancy using two separate but identical LANs.

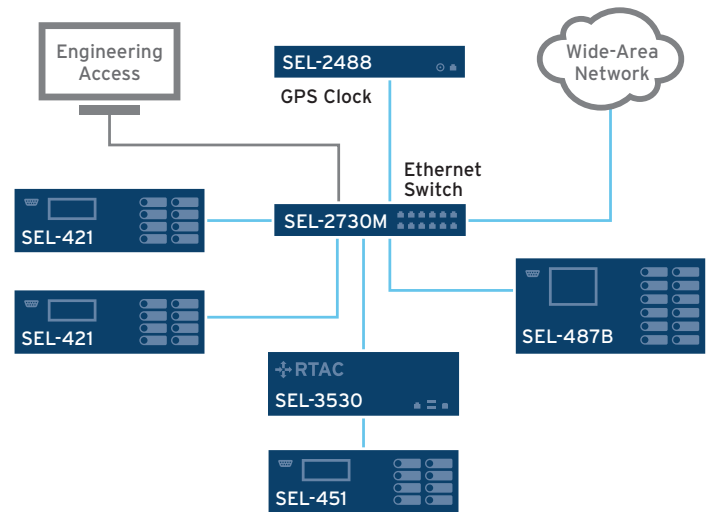

Typical Ethernet network configuration.

Specifications

General	
AC Current Inputs (21 total)	5 A nominal 1 A nominal
AC Voltage Inputs (3 total)	300 V _{L-N} continuous, 600 Vac for 10 seconds
Serial	1 front-panel and 3 rear-panel EIA-232 serial ports 300–57,600 bps
Ethernet	Communications protocols include FTP, Telnet, DNP3 LAN/WAN, PRP, PTPv2, and IEC 61850 Edition 2 (optional). Choose from the following port options: Two 10/100BASE-T twisted-pair network ports Two 100BASE-FX fiber-optic network ports One 10/100BASE-T twisted-pair network port and one 100BASE-FX fiber-optic network port
TiDL Ports	Fiber-optic ports: 8 Range: ~2 km Data rate: 100 Mbps
Precise-Time Input	Demodulated IRIG-B time input and PTPv2
Processing	AC voltage and current inputs: 8,000 samples per second Protection and control processing: 12 times per power system cycle
Power Supply	24–48 Vdc 48–125 Vdc or 110–120 Vac 125–250 Vdc or 110–240 Vac
Operating Temperature	–40° to +85°C (–40° to +185°F) Note: LCD contrast is impaired for temperatures below –20°C (–4°F) and above +70°C (+158°F).

SCHWEITZER ENGINEERING LABORATORIES

Making Electric Power Safer, More Reliable, and More Economical
Tel: +1.509.332.1890 | Email: info@selinc.com | Web: www.selinc.com

