



SEL-411L Data Sheet

Line Current Differential Protection Automation and Control System



Major Features and Benefits

The SEL-411L Protection, Automation, and Control System combines high-speed line current differential, distance, and directional protection with complete control for a two-breaker bay.

- **Line Current Differential Protection.** The 87L function of the SEL-411L provides protection for any transmission line or cable with as many as three terminals over serial communications and as many as four terminals over Ethernet communications, in three-pole or single-pole tripping modes. Each terminal can be connected in a dual breaker arrangement. The SEL-411L applies a generalized Alpha Plane algorithm that you can use for such applications as multiple currents in the differential zone, applications with harmonic restraint or blocking for in-line transformers, and line-charging current compensation.
- **Dual Current Input.** For breaker-and-a-half, ring-bus, or double-bus double-breaker bus applications, the SEL-411L provides proper security for the 87L function by supporting two current inputs for individual measurements of each breaker. Through the use of SELOGIC[®] control equations, you can dynamically include or exclude each current input from the differential zone. With this capability, you can use the SEL-411L in such advanced applications as breaker substitution in double-bus single-breaker or transfer bus configurations.
- **Generalized Alpha Plane.** Phase-segregated (87LP), negative-sequence (87LQ), and zero-sequence (87LG) differential elements use patented generalized Alpha Plane comparators. Combined with over-current supervision, external fault detection, optional charging current compensation, and disturbance detection logic, these provide the 87L function with exceptional security and sensitivity. An adaptive feature increases security of the 87L function if:
 - An external fault is detected
 - Communications synchronization is degraded
 - Charging current compensation is enabled but momentarily impossible because of loss-of-potential (LOP) or other conditions

The generalized Alpha Plane principle is similar to the two-terminal SEL-311L. However, the SEL-311L and SEL-411L are two completely independent hardware and firmware platforms. They are not compatible to be applied in a line-current differential scheme.

- **Inclusion of Power Transformers in the Protective Zone.** The SEL-411L allows for in-line power transformer applications by compensating for transformer vector group, ratio, and zero-sequence current. The 87L function supports both harmonic blocking and/or harmonic restraint for stabilization during transformer inrush conditions. During over-excitation conditions, the SEL-411L uses fifth harmonic current to secure the 87L elements. The 87L function can protect multiwinding transformers.
- **Charging Current Compensation.** Line-charging current compensation enhances sensitivity of the 87L elements in applications of the SEL-411L for protection of long, extra high voltage lines or cables. Charging current is calculated by using the measured line terminal voltages. This value is then subtracted from the measured phase current. This compensation method results in accurate compensation for both balanced and unbalanced system conditions. This method works for line pickup even when uneven breaker operation occurs. The line-charging current algorithm has built-in fallback logic in the event of an LOP condition.
- **External Fault Detector.** An external fault detection algorithm secures the 87L elements against CT errors when the algorithm detects one of the two following conditions:
 - An increase in the through current of the protected zone that is not accompanied by an increase in the differential current of the protected zone (typical of an external fault)
 - The dc component of any current exceeds a preset threshold compared with the ac component without the differential current having a significant change (typical when energizing a line reactor or a power transformer)
- **Communications Protocols Supported.** The SEL-411L allows serial 87L communication over direct point-to-point fiber, C37.94 multiplexed fiber, EIA-422, and G.703 media.
- **Data Synchronization.** Synchronize data exchanged between relays based on the channel (for symmetrical channels) or use external time sources for applications over asymmetrical channels. You have free control of the synchronization method on a per-channel basis. Connect external time sources, if necessary, via a standard IRIG-B input. These can be based on GPS technology, or you can use a terrestrial, secure distribution of time from the SEL ICON multiplexer system. If you use external time sources, the SEL-411L provides built-in fallback logic to deal with any loss or degradation of such sources.
- **IEEE 1588, Precision Time Protocol.** The relay shall support Precision Time Protocol version 2 (PTPv2). PTP provides high-accuracy timing over an Ethernet network.
- **Complete Distance Protection.** Apply as many as five zones of phase- and ground-distance and directional overcurrent elements. Select mho or quadrilateral characteristics for any phase- or ground-distance element. Use the optional high-speed distance elements and series-compensation logic to optimize protection for critical lines or series-compensated lines. Patented coupling capacitor voltage transformer (CCVT) transient overreach logic enhances the security of Zone 1 distance elements. Best Choice Ground Directional Element[®] logic optimizes directional element performance and eliminates the need for many directional settings. Apply the distance and directional elements in communications-based protection schemes such as POTT, DCB, and DCUB, or for instantaneous or time-step backup protection.
- **Automation.** Take advantage of enhanced automation features that include programmable elements for local control, remote control, protection latching, and automation latching. Local metering on the large-format, front-panel liquid crystal display (LCD) eliminates the need for separate panel meters. Use serial and Ethernet links to efficiently transmit key information, including metering data, protection element and control I/O status, IEEE C37.118 synchrophasors, IEC 61850 GOOSE messages, Sequential Events Recorder (SER) reports, breaker monitor, relay summary event reports, and time synchronization. Use expanded SELOGIC control equations with math and comparison functions in control applications. High-isolation control input circuits feature settable assertion levels for easy combinations of elements from other systems. Incorporate as many as 1000 lines of automation logic to accelerate and improve control actions.
- **Software-Invertible Polarities.** Invert individual or grouped CT and PT polarities to account for field wiring or zones of protection changes. CEV files and all metering and protection logic use the inverted polarities, whereas COMTRADE event reports do not use inverted polarities but rather record signals as applied to the relay.
- **Synchrophasors.** Make informed load dispatch decisions based on actual real-time phasor measurements from SEL-411L relays across your power system. Record streaming synchrophasor data from SEL-411L relays with system-wide disturbance recording. Use wide-area remote synchrophasor data to control the power system.

- **Digital Relay-to-Relay Communications.** The SEL-411L provides communications options that are independent and isolated from the 87L ports and channels. Use MIRRORED BITS[®] communications to monitor internal element conditions among relays within a station, or among stations, through the use of SEL fiber-optic transceivers. Send digital, analog, and virtual terminal data over the same MIRRORED BITS channel. Receive synchrophasor data from as many as two other devices transmitting IEEE C37.118-2005 format synchrophasors at rates as fast as 60 messages per second. Send and receive digital and analog data via IEC 61850 GOOSE messages for high-speed communication between relays. The SEL-411L time correlates the data for use in SELOGIC control equations. You can also use the relay to transmit user-programmable bits embedded within 87L data streams.
- **Primary Potential Redundancy.** Multiple voltage inputs to the SEL-411L provide primary voltage input redundancy. Upon an LOP detection, the relay can use inputs from an electrically equivalent source connected to the relay.
- **Ethernet Access.** Access all relay functions with the optional Ethernet card. Use IEC 61850 MMS or DNP3 protocol directly to interconnect with automation systems. You can also connect to DNP3 networks through a communications processor. Use file transfer protocol (FTP) for high-speed data collection. Connect to substation or corporate LANs to transmit synchrophasors in the IEEE C37.118-2005 format by using TCP or UDP Internet protocols.
- **Breaker and Battery Monitoring.** Schedule breaker maintenance when accumulated breaker duty (independently monitored for each pole of two circuit breakers) indicates possible excess contact wear. The SEL-411L records electrical and mechanical operating times for both the last operation and the average of operations since function reset. Alarm contacts provide notification of substation battery voltage problems (two independent battery monitors) even if voltage is low only during trip or close operations.
- **Reclosing Control.** Incorporate programmable single-pole or three-pole trip and reclose of one or two breakers into an integrated substation control system. Synchronism and voltage checks from multiple sources provide complete bay control.
- **Breaker Failure Protection.** Use high-speed (5/8 cycle) open-pole detection logic to reduce total clearing times for critical breaker failure protection applications. Apply the SEL-411L to supply single- and/or three-pole breaker failure protection for one or two breakers. The relay includes logic for single-pole and three-pole breaker failure retrip and initiation of transfer tripping. It also includes logic for using different delay settings for multiphase and single-phase tripping.
- **Out-of-Step Blocking and Tripping.** Select out-of-step blocking of distance elements or tripping on unstable power swings. Zero-setting out-of-step detection logic is available. With such logic, neither settings nor system studies are necessary.
- **Switch-Onto-Fault and Stub Bus Protection.** Use disconnect status inputs and voltage elements to enable high-speed stub bus protection and proper response toward remote SEL-411L relays. Stub bus protection in the SEL-411L provides a true restrained differential function that yields exceptional security in dual-breaker applications.
- **High-Accuracy Traveling Wave Fault Locator.** On two terminal lines with a high-accuracy time source, the SEL-411L achieves the highest possible fault location accuracy with a type D (double ended) traveling wave (TW) algorithm. A dedicated analog-to-digital converter samples currents at 1.5625 MHz and extracts high-frequency content to calculate fault location.
- **Advanced Multiterminal Fault Locator.** Efficiently dispatch line crews to quickly isolate line problems and restore service faster. For two-terminal lines, the SEL-411L uses data from each terminal to achieve highly accurate fault location with a type D traveling wave algorithm and with an impedance-based fault location estimate. For three-terminal lines, you can accurately locate faults by using data from each terminal to compute a three-terminal impedance-based fault location estimate. The SEL-411L shares data from each line end to correctly identify a faulted line segment. Upon loss of communication or degraded data synchronization, the relay returns to a single-ended method, always providing valuable fault location results to aid inspection and repair. The SEL-411L displays all traveling wave and impedance-based fault location estimates.
- **Oscillography.** Record voltages, currents, and internal logic points at sampling rates as fast as 8 kHz and with time-stamp based on absolute time. Phasor and harmonic analysis features allow investigation of relay and system performance. Fault reports include both local and remote 87L data, allowing fast and convenient analysis.

- **Rules-Based Settings Editor.** Use an ASCII terminal to communicate and set the relay, or use the PC-based ACCELERATOR QuickSet[®] SEL-5030 Software to configure the SEL-411L, analyze fault records with relay element response, and view real-time phasors and harmonic levels.
- **Sequential Events Recorder (SER).** Record the last 1000 entries, including setting changes, relay turn on, and selectable logic elements.
- **IEC 60255-Compliant Thermal Model.** Use the relay to provide a configurable thermal model for the protection of a wide variety of devices.
- **Comprehensive Metering.** Improve feeder loading by using built-in, high-accuracy metering functions. Use watt and VAR measurements to optimize feeder operation. Use differential metering to access remote terminal current values. Eliminate standalone meters and instead use such full metering capabilities of the SEL-411L as rms, maximum/minimum, demand/peak, energy, and instantaneous values.

Functional Overview

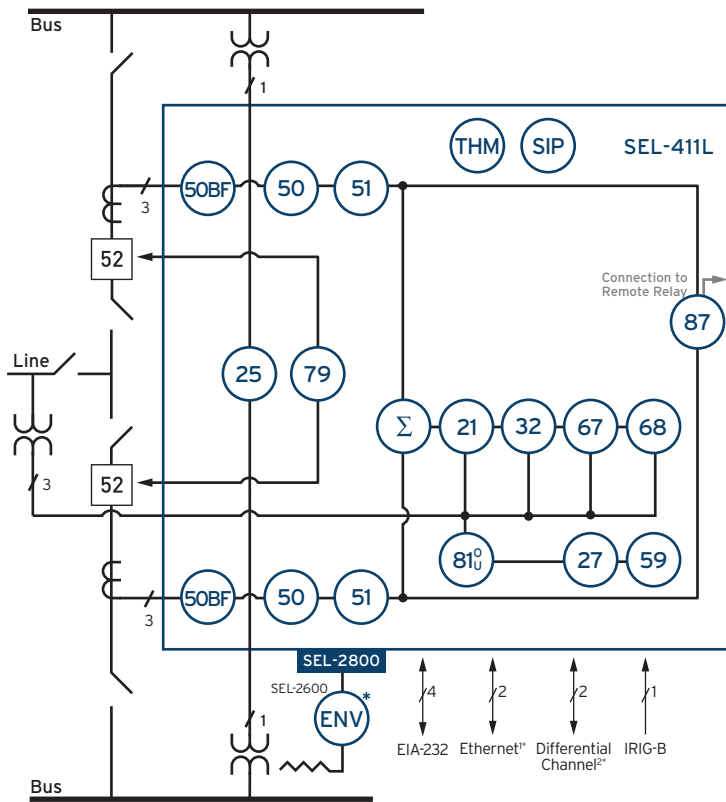

ANSI NUMBERS/ACRONYMS AND FUNCTIONS

21	Phase and Ground Distance
25	Synchronism Check
27	Undervoltage
32	Directional Power
50	Overcurrent
50BF	Dual Breaker Failure Overcurrent
51	Time-Overcurrent
59	Overvoltage
67	Directional Overcurrent
68	Out-of-Step Block/Trip
79	Single- and Three-Pole Reclosing
81 (O, U)	Over- and Underfrequency
85 RIO	SEL MIRRORRED BITS Communications
87	Current Differential
DFR	Event Reports
ENV	SEL-2600*
HMI	Operator Interface
LGC	Expanded SELogic Control Equations
MET	High-Accuracy Metering
PMU	Synchphasors
SER	Sequential Events Recorder

ADDITIONAL FUNCTIONS

BRM	Breaker Wear Monitor
LDE	Load Encroachment
LOC	Fault Locator
SBM	Station Battery Monitor
SIP	Software-Invertible Polarities
THM	IEC 60255-Compliant Thermal Model

¹ Copper or Fiber Optic
² Serial or Ethernet
 * Optional Feature

Figure 1 Functional Diagram

Protection Features

The SEL-411L contains all the necessary protective elements and control logic to protect overhead transmission lines and underground cables (see Figure 2).

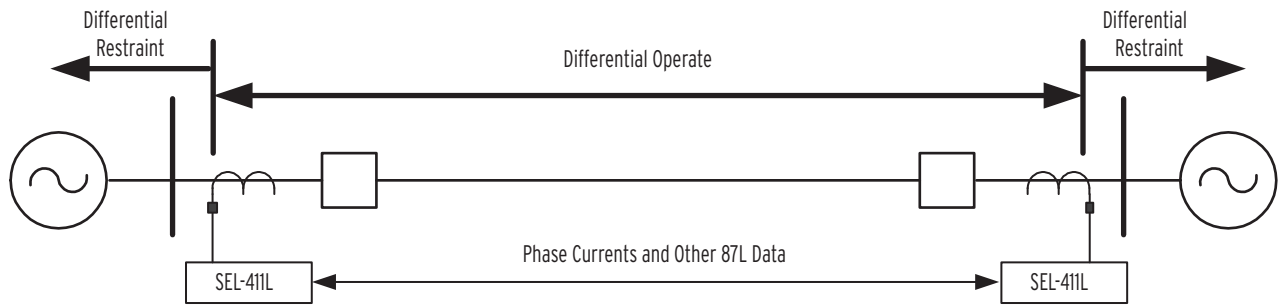

Figure 2 Differential Element Operate and Restraint Regions

Complete Current Differential Protection

The SEL-411L differential elements compare phase, negative-sequence, and zero-sequence components from each line terminal, as *Figure 2* illustrates.

The differential protection in the SEL-411L checks the vector ratio of the equivalent local and remote currents in a complex plane, known as the Alpha Plane, as *Figure 3* shows. For load and external faults, with no CT or communication errors, the vector ratio of remote current to local current is -1 or $1 \angle 180^\circ$. The SEL-411L restraint region surrounds the ideal external fault and load current point, allowing for errors in both magnitude and phase angle. CT saturation, channel asymmetry, and other effects during faults outside the protected zone produce shifts in the magnitude and angle of the ratio. The restraint characteristic provides proper restraint for these conditions and still detects, with its negative- and zero-sequence differential elements, high-resistance faults and “outfeed” faults that occur within the protected zone. You can adjust both the angular extent and the radial reach of the restraint region.

The differential protection algorithms are insensitive to CT saturation effects. In addition to providing individual breaker currents to the differential element, the relay incorporates ultra fast external fault detection to cope with fast and severe CT saturation resulting from high fault currents. It also provides a standing dc detection algorithm to cope with slower saturation resulting from large and slowly decaying dc offset in the transformer inrush or fault currents under large X/R ratios. Such provisions prevent the SEL-411L from tripping on through faults and allows relaxation of CT requirements for SEL-411L applications. SEL-411L current

connections add very little burden, so you can add line current differential protection to multiuse CTs without degradation of accuracy or protection security.

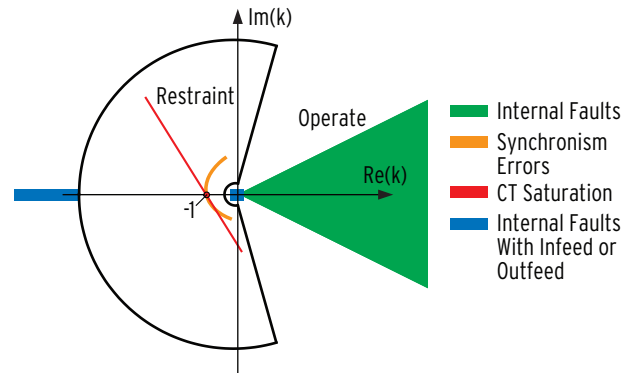

Figure 3 Operate and Restraint Regions in Alpha Plane Responses to System Conditions

Two-Breaker Bays and Multiterminal Lines

The SEL-411L can accommodate lines terminated as dual-breaker connections or multiterminal lines for as many as six current inputs with serial communications. The relays measure and use all of the current inputs (*Figure 4a*) and calculate an equivalent two-terminal Alpha Plane current (*Figure 4b*). The relay produces restraint measures and runs external fault detection in response to all individual currents of the differential zone. The relays use a patented method to develop a remote and local current for an equivalent two terminal system (*Figure 4c*). The equivalent local and remote currents are applied to the tried and true alpha plane comparator (*Figure 4d*). As a result, the SEL-411L extends the advantages of an alpha plane implementation to dual-breaker multi-terminal lines.

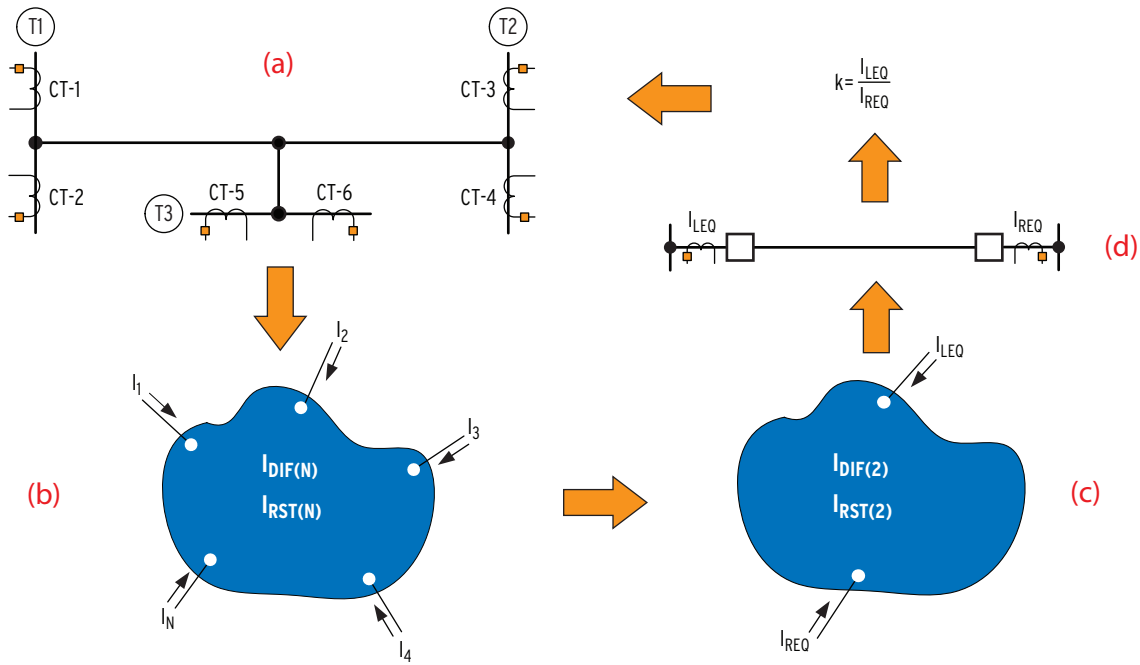

Figure 4 Illustration of the Generalized Alpha Plane Operating Principle

Line-Charging Current Compensation

The SEL-411L compensates for line-charging current by estimating an instantaneous value of the total line-charging current on a per-phase basis and then subtracting this value from the measured differential current. The relay uses instantaneous values of the line voltage and the susceptance of the line (cable), to calculate charging current in real time on a sample-by-sample basis.

This method is accurate under steady state and transient conditions. These latter conditions can include external faults, internal faults, switching events, and line energization, even with uneven breaker pole operation. Compensating the phase currents removes the charging current from the sequence currents automatically and improves the sensitivity of the sequence 87L elements.

Each SEL-411L terminal with access to voltage uses the lump parameter model of the transmission line and the local terminal voltage to calculate the total charging current:

$$i_{CHARGE} = C_{LINE} \cdot \frac{dv}{dt}$$

The relay subtracts a portion of the total charging current proportional to the number of compensating terminals from the local phase current. For example, with two relays compensating for the charging current, each subtracts half of the total charging current:

$$i_{LOC1} = i_{MEASURED1} - 0.5 \cdot C_{LINE} \cdot \frac{dv_1}{dt}$$

$$i_{LOC2} = i_{MEASURED2} - 0.5 \cdot C_{LINE} \cdot \frac{dv_2}{dt}$$

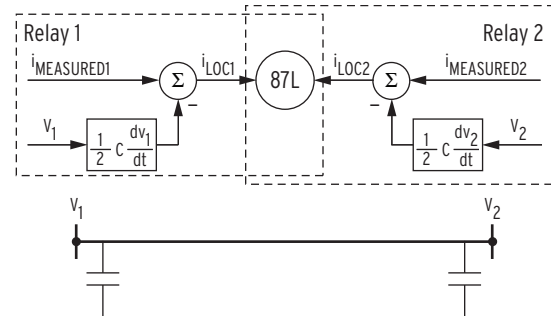

Figure 5 Illustration of Signal Processing for Line-Charging Current Compensation

When the relays calculate the differential currents, they will arrive at the following compensated value:

$$i_{DIF} = i_{LOC1} + i_{LOC2} = i_{MEASURED1} + i_{MEASURED2} - C_{LINE} \cdot \frac{d}{dt} \cdot \frac{v_1 + v_2}{2}$$

Note that the term:

$$C_{LINE} \cdot \frac{d}{dt} \cdot \frac{v_1 + v_2}{2}$$

represents the total line-charging current the relays calculate through use of the full line capacitance and the average terminal voltage. The average terminal voltage represents the voltage profile better than any particular single voltage along the line length, and its use improves the accuracy of the charging current compensation.

By subtracting the total charging current from the differential signal prior to using the generalized Alpha Plane algorithm, the relay moves the operating point to the ideal blocking point ($1 \angle 180^\circ$) when no internal fault conditions exist. This allows more sensitive settings, particularly for the 87LP element.

A loss of voltage at one of the line terminals causes the scheme to use remaining voltages, with properly adjusted multipliers, for compensation, resulting in removal of the total line charging current. If no compensation is possible, the fallback logic engages more secure settings to retain security of protection.

External Fault Detection

An external fault detection algorithm analyzes particular characteristics of the 87L zone currents to identify external events as a fault, load pickup under exceptionally high X/R ratio, or a transformer inrush condition that could jeopardize 87L security with possible subsequent CT saturation. Assertion of the algorithm occurs before and regardless of CT saturation, bringing proper security to the 87L scheme, particularly to the 87LQ and 87LG elements.

The external fault detection algorithm consists of two paths:

- The “ac saturation” path guards against potentially fast and severe CT saturation resulting from high current magnitudes such as those occurring during close-in external faults.
- The “dc saturation” path guards against typically slower and less severe saturation that can result from relatively large and long-lasting dc component in current signals as can exist during transformer inrush or slowly cleared external faults under large X/R ratios.

Figure 6 shows a simplified logic diagram of the ac saturation path of the algorithm. The principle of operation is based on the observation that all CTs of the differential zone perform adequately for a short time into the fault. If so, the differential current does not develop during the external faults, but the restraint current increases. This external fault pattern differs from the internal fault pattern in that both the differential and restraint currents develop simultaneously. The algorithm monitors the difference by responding to changes in the instantaneous differential current and the instantaneous restraint currents the relay measures during one power cycle. The algorithm declares an external fault if it detects sufficient increase in the restraint current, there is no accompanying increase in differential current, and the situation persists for a predetermined portion of a power cycle. When both currents develop simultaneously, the EFD_{AC} logic does not assert.

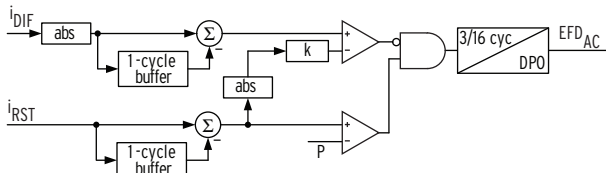

Figure 6 AC Saturation Path of the External Fault Detector

Figure 7 shows a simplified logic diagram of the dc saturation path. The logic checks if the dc component in any of the local 87L zone currents is relatively high, as compared with the CT

nominal and the ac component at the time. If the dc component is high, and the differential current is low compared with the restraining current, EFD_{DC} asserts in anticipation of possible CT saturation resulting from overfluxing by the dc component.

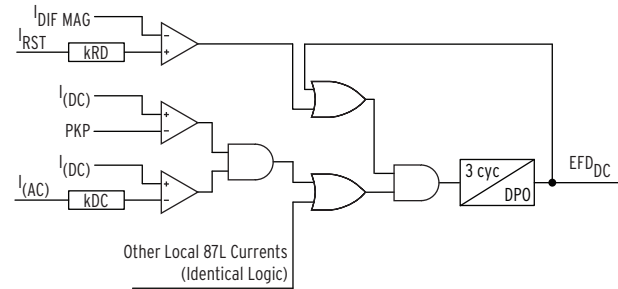

Figure 7 DC Saturation Path of the External Fault Detector

The SEL-411L combines the output from both logics to drive an external fault-detected (EFD) Relay Word bit. The relay uses the OR combination of the ac path and the dc path not only to drive the local external fault detector, but also to transmit information about the external fault to all remote terminals.

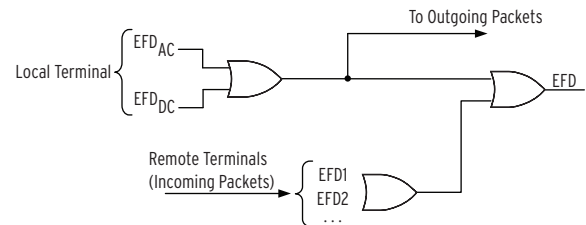

Figure 8 Combined External Fault Detector

The EFD Relay Word that we see as the output of Figure 8 is an OR combination of the local and remote external fault detectors. In this way, all terminals receive an alert about an external fault even if one of the terminals has minimal current contribution to the fault. Upon assertion of the EFD Relay Word bit, all 87L elements switch to high security mode. No user settings are necessary for the EFD logic.

In-Line Transformers

The 87L function performs in-line power transformer vector group, ratio, and zero-sequence compensation as per the art of transformer protection. The function also provides logic for blocking during overexcitation conditions and offers both harmonic restraint and blocking to accommodate transformer inrush. Proper compensation of the measured current occurs at the local relay prior to remote terminal transmission of current data. Once the local relay receives data from the remote terminals, it can consume these data through use of the same signal processing and algorithms as in the plain line application (see Figure 9).

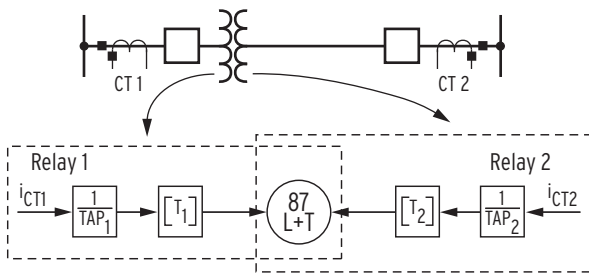

Figure 9 Compensation for In-Line Transformers at the Local Relay Allows the Algorithms to Remain Unchanged

Security With Respect to Communication Events

Noise in a communications channel can corrupt data. The SEL-411L uses a 32-bit BCH code to protect data integrity. Any data integrity protection has a non-zero probability of defeat. To reduce the probability that a standing noise condition could result in corrupted data and an unwanted 87L operation, the SEL-411L has sensitive and fast-acting disturbance detectors as *Figure 10* illustrates.

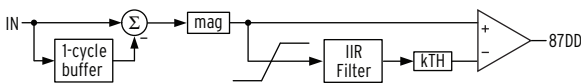

Figure 10 Adaptive Disturbance Detector Algorithm

Corrupted data that would activate the 87L elements or assert the 87 direct transfer trip (87DTT) would be short lived and constitute typically just a single packet. The SEL-411L supervises the 87L elements and 87DTT with the disturbance detector. As *Figure 11* illustrates, the 87L element or 87DTT element is delayed slightly without losing dependability even if the disturbance detectors were to fail to assert.

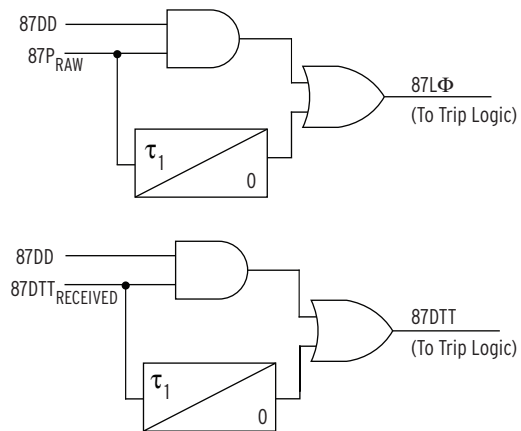

Figure 11 SEL-411L Disturbance Detection Application

The disturbance detectors are sensitive, but they will not assert under load conditions for periodic current or voltages, even for heavily distorted load current or voltages. No user settings are necessary for the disturbance detection logic.

Single-Pole Tripping From 87L Elements

The SEL-411L allows single-pole tripping from the 87L elements. This includes tripping highly resistive faults from the sensitive 87LQ and 87LG elements. These 87LQ and 87LG elements do not have inherent faulted phase identification capabilities. Therefore, the 87L function incorporates its own faulted phase selection logic and uses symmetrical components in the phase differential currents to provide very sensitive, accurate, and fast fault type identification. The differential current available to the SEL-411L is the fault current at the fault point. The angular relationships between the symmetrical components of this fault current allow very accurate phase selection, even under the presence of some charging current, standing CT errors, or some data synchronization errors. The relay also uses this faulted phase selection logic when tripping from the 87LP phase elements because these elements are less sensitive and can vary in dependability among the three phases according to fault resistance and other conditions.

When performing single-pole tripping in the slave mode from the 87DTT logic, the SEL-411L uses a proven single-ended fault identification logic based on the angular relationships in the local current.

Operating Time Curves for 87 Elements

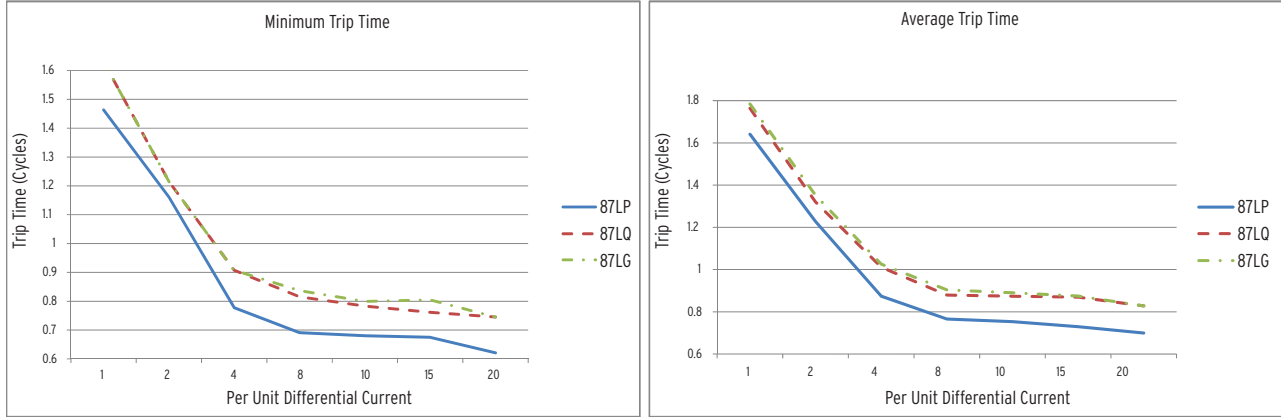

Figure 12 Operating Time Curves

87 Channel Monitoring

To aid commissioning and to help maintain security and dependability, the SEL-411L provides a set of channel monitoring and alarming functions. Considering that the 87L function is communications-dependent, it is beneficial to monitor the status of the communications channels during in-service operation to detect abnormal or unexpected conditions and initiate corrective actions. The 87L function itself responds to some monitored channel characteristics in real time to maintain proper security and dependability. Also, checking for specified performance of the communications channels is an integral part of a typical commissioning procedure for the 87L function.

The monitoring functions of the SEL-411L include a round-trip channel delay, step change in the round-trip delay signifying path switching, noise burst and momentary channel break detection, channel asymmetry, 40 second and 24h lost packet counts, data integrity alarm, and wrong relay address alarm signifying cross-connection of communications paths. These monitoring functions provide overall assessment of channel quality for the user and feed into the internal 87L logic for security.

87L Communications Report

The SEL-411L provides an 87L communications report to visualize and summarize basic 87L configuration as well as real-time and historical channel monitoring and alarming values. The report covers three major areas:

- 87L configuration and overall status such as relay identification, number of terminals in the 87L scheme, master or slave mode, channel problems, stub bus condition, in test, etc.
- Detailed channel configuration, diagnostics, and health information on a per-channel basis. Such information includes remote relay address, data synchronization method and status, list of any specific channel alarms asserted, round-trip channel delay, and channel asymmetry.

- Such long-term channel characteristics on a per-channel basis as channel delay histogram, and worst-case channel delay with time stamp.

87L Channel Redundancy

The SEL-411L provides optional channel redundancy in two-terminal serial applications. You can order the SEL-411L with two 87L serial communications ports, which you can then use to connect two relays in a redundant fashion, incorporating different, typically independent communications equipment and paths. Often a direct point-to-point fiber connection is the primary channel, and a multiplexed channel over a SONET network serves as backup. The SEL-411L simultaneously sends data on both channels, and incorporates channel monitoring functions and logic to automatically switch between the primary and backup channels on the receiving end to maximize dependability and security (Figure 13). Excessive round-trip channel delay, elevated lost packet counts, detected channel asymmetry, and user-programmable conditions can all serve as triggers to initiate channel switchover. The switchover logic responds quickly to degraded channel conditions while maintaining proper security during the transition from the primary to backup channels or vice versa.

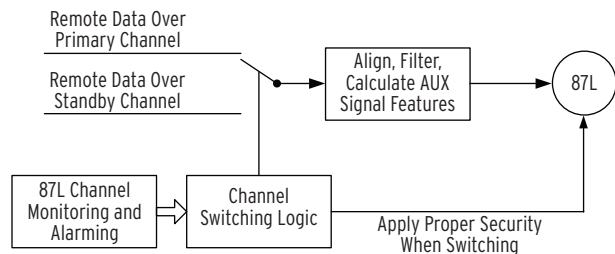

Figure 13 Redundant Channel Logic

Complete Distance Protection

The SEL-411L simultaneously measures as many as five zones of phase and ground mho distance protection plus five zones of phase and ground quadrilateral distance protection.

You can apply these distance elements, together with optional high-speed directional and faulted phase selection and high-speed distance elements, in communications-assisted and step-distance protection schemes. You can use expanded SELOGIC control equations to tailor the relay further to your particular application.

Figure 14, Figure 15, Figure 16 and Figure 17 show the performance times of the high-speed and standard distance elements for a range of faults, locations, and source impedance ratios (SIR). As competitive and regulatory pressures push transmission systems to operational limits, line protection must be able to adapt to changing conditions. The SEL-411L is easy to set and use for typical lines, while high-speed and logic settings allow it to be applied for critical and hard-to-protect lines.

Subcycle Tripping Times Using Optional High-Speed Distance Elements

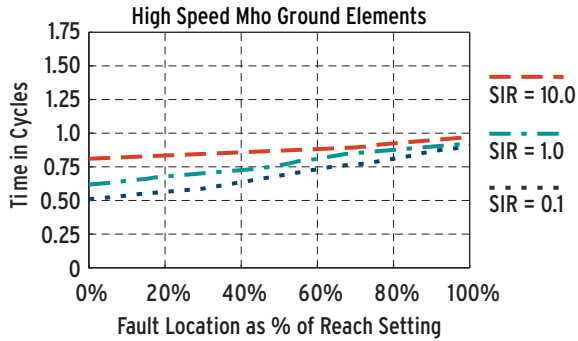

Figure 14 Mho Single-Phase-to-Ground Faults

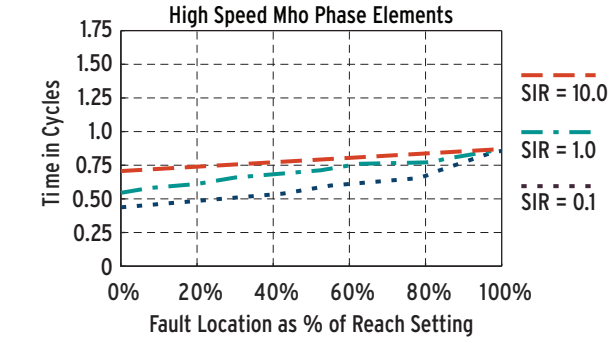
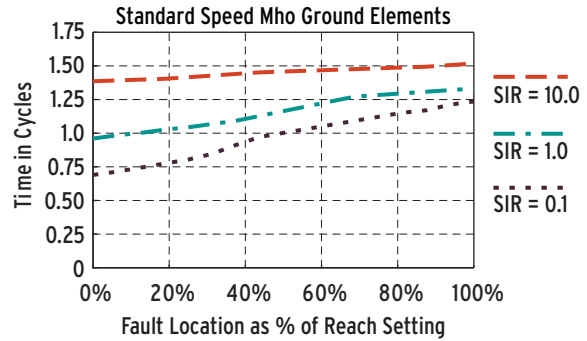

Figure 15 Mho Phase-to-Phase Faults

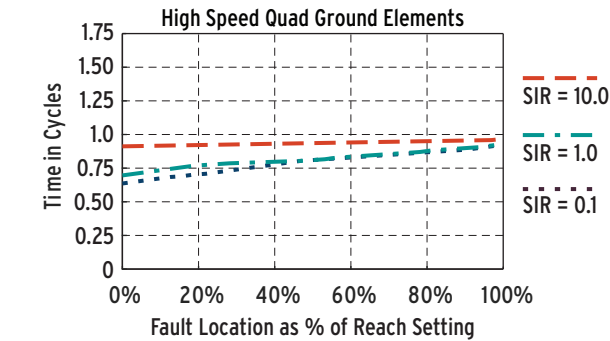
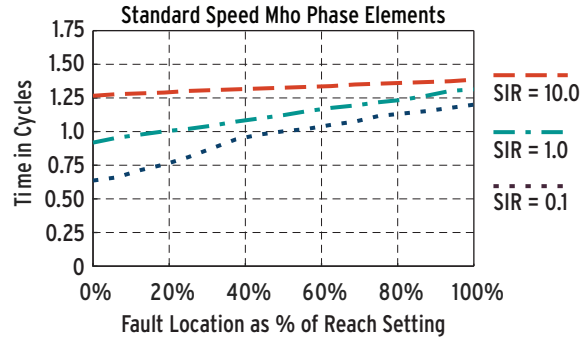
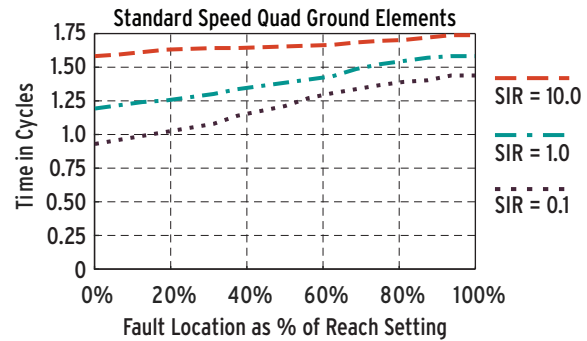

Figure 16 Quadrilateral Single-Phase-to-Ground Faults



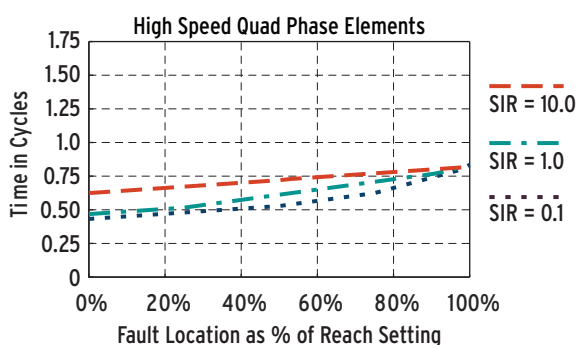
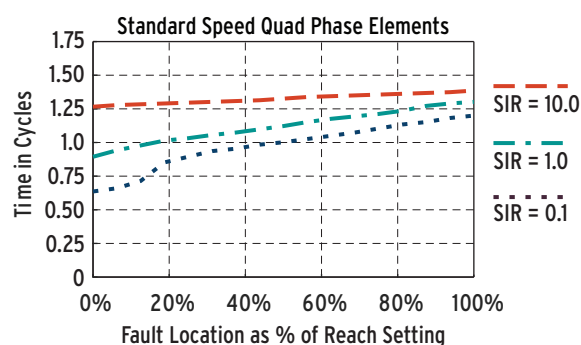

Figure 17 Quadrilateral Phase-to-Phase Faults



Mho Distance Elements

The SEL-411L uses mho characteristics for phase- and ground-distance protection. Two zones are fixed in the forward direction, and the remaining three zones can be set for either forward or reverse. All mho elements use positive-sequence memory polarization that expands the operating characteristic in proportion to the source impedance (Figure 18). This provides dependable, secure operation for close-in faults.

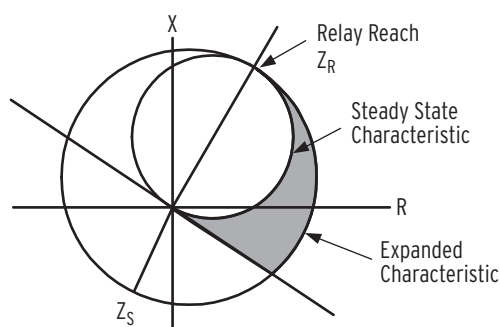

Figure 18 Mho Characteristic

As an optional addition to the standard distance elements, there are three zones (either three forward, or two forward and one reverse) of high-speed distance elements. These high-speed elements use voltage and current phasors derived from a fast half-cycle filter to provide subcycle tripping times. Settings are automatically associated with the standard element zone reach; no additional settings are necessary.

The SEL-411L includes optional series-compensated line logic and polarizing to prevent overreach of the Zone 1 distance element resulting from the series capacitor transient response.

Load-Encroachment Logic

Load-encroachment logic (Figure 19) prevents operation of the phase-distance elements under high load conditions. This feature permits load to enter a predefined area of the phase-distance characteristic without causing a trip.

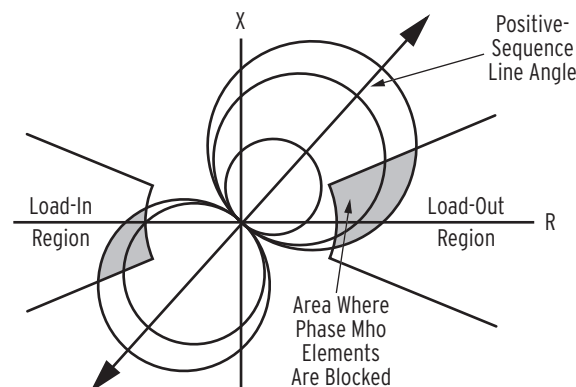

Figure 19 Load-Encroachment Logic

CCVT Transient Detection Logic

CCVT transient detection, once enabled, automatically prevents incorrect operation of the direct tripping (Zone 1) distance elements. The relay determines the source impedance ratio (SIR), and a smoothness detection system acts to inhibit Zone 1 only for those conditions that indicate a CCVT transient exists. No user settings are necessary.

Phase and Ground Quadrilateral Distance Elements

The SEL-411L provides five zones of quadrilateral phase- and ground-distance characteristics for improved fault and arc resistance coverage including applications to short lines. The reaction line of the quadrilateral characteristic automatically tilts with load flow to avoid under- and overreaching. Available settings prevent overreaching of the quadrilateral characteristic from nonhomogeneous fault current components. You can choose to disable the mho and quadrilateral distance elements or use them either separately or concurrently.

Each of the distance elements has a specific reach setting. The ground-distance elements include three zero-sequence compensation factor settings ($k01$, $k0R$, and $k0F$) to calculate ground fault impedance accurately. Setting $k01$ uses positive-sequence quantities to adjust the zero-sequence transmission line impedance for accurate measurement. Settings $k0F$ and $k0R$ account for forward and reverse zero-sequence mutual coupling between parallel transmission lines.

Directional Elements Increase Sensitivity and Security

The SEL-411L includes a number of directional elements for supervision of overcurrent elements and distance elements. The negative-sequence directional element uses the same patented principle proven in our SEL-321 and SEL-421 relays. You can apply this directional element in virtually any application, regardless of the amount of negative-sequence voltage available at the relay location.

The following three directional elements working together provide directional control for the ground overcurrent elements by:

- Negative-sequence voltage-polarized directional element
- Zero-sequence voltage-polarized directional element
- Zero-sequence current-polarized directional element

Our patented Best Choice Ground Directional Element selects the best ground directional element for system conditions and simplifies directional element settings. (You can override this automatic setting feature for special applications.)

Optional High-Speed Directional and Faulted Phase Selection (HSDPS) Element

In addition to standard directional elements, the SEL-411L can include an HSDPS function that uses incremental voltage and current phasors. This function derives incremental quantities by comparing the measured signal to the same signal a short time earlier. The HSDPS provides directional and faulted phase selection outputs much faster than conventional algorithms and allows faster (less than one cycle) relay operation.

Communications-Assisted Tripping Schemes

Use MIRRORING BITS communications with SEL fiber-optic transceivers for 3–6 ms relay-to-relay transmission time for pilot-tripping schemes. The relay supports communications ports or conventional inputs for the communications-assisted schemes that are independent and isolated from the 87L communications. This allows for true redundancy between the 87L channels and communications-assisted scheme channels. Among the schemes supported are the following:

- Permissive Overreaching Transfer Tripping (POTT) for two- or three-terminal lines
- Directional Comparison Unblocking (DCUB) for two- or three-terminal lines
- Directional Comparison Blocking (DCB)

Use the SEL control equation TRCOMM to program specific elements, combinations of elements, inputs, etc., to perform communications scheme tripping and other scheme functions. The logic readily accommodates the following conditions:

- Current reversals
- Breaker open
- Weak-infeed conditions
- Switch-onto-fault conditions

Step distance and time-overcurrent protection provide reliable backup operation in the case of lost channels for the 87L elements and communications-assisted schemes.

Overcurrent Elements

The SEL-411L includes four phase, four negative-sequence, and four ground instantaneous overcurrent elements. The SEL-411L also includes ten selectable operating quantity inverse-time overcurrent elements. You can select the operating quantities from the following:

I|A|, I|B|, I|C|, MAX(I|A|, I|B|, I|C|), I|1|, I|3I2|, I|G|, I|87IA|, I|87IB|, I|87IC|, I|87I1|, I|87I2|, I|87IG|

The time-overcurrent curves (listed in *Table 1*) have two reset characteristic choices for each time-overcurrent element. One choice resets the elements if current drops below pickup for one cycle. The other choice emulates the reset characteristic of an electromechanical induction disc relay.

Table 1 Time-Overcurrent Curves

US	IEC
Moderately Inverse	Standard Inverse
Inverse	Very Inverse
Very Inverse	Extremely Inverse
Extremely Inverse	Long-Time Inverse
Short-Time Inverse	Short-Time Inverse

Time-Overcurrent Differential Protection

The SEL-411L allows protection of lines with tapped loads without the current measurement at the tap. You can make such partial line current differential applications selective, and these may be acceptable if you connect tapped and unmeasured load through a step-down power transformer. The transformer impedance reduces the level of line differential currents for network faults fed from the low side of the transformer, providing better coordination margins.

This application allows you to protect lines having multiple load taps without the need to invest in high-grade communications and install the SEL-411L relays at every tap of the line.

Overall, in the partial line current differential applications of the SEL-411L, we suggest following this approach:

- The 87L elements are applied as instantaneous but are intentionally desensitized to prevent operation for faults in the tapped load.
- The differential time overcurrent elements provide sensitive, but time-coordinated protection for the low-current line faults, some internal faults in the tapped transformer, and remote back-up for short-circuit protection in the tapped load network.

Use the selectable time-overcurrent elements to configure the differential time-overcurrent protection while coordinating with the phase-sequence, negative-sequence, or zero-sequence short-circuit protection of the tapped load network.

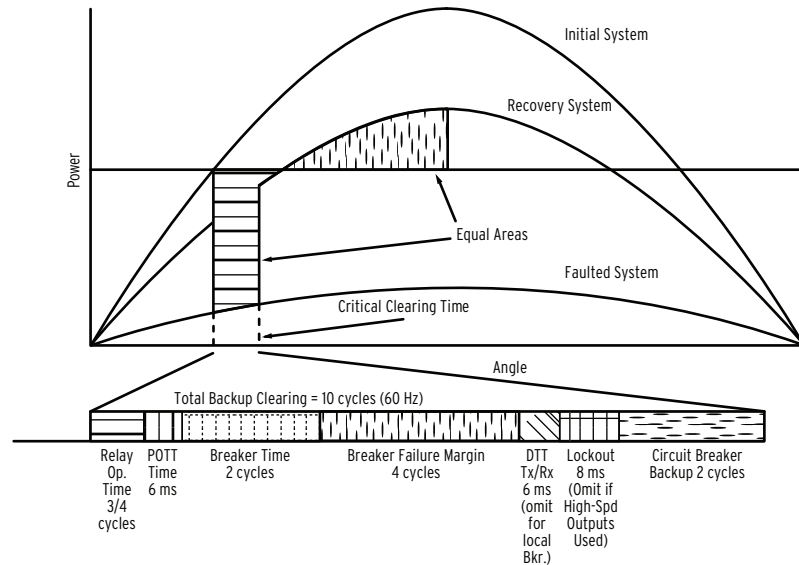

Figure 20 Combining High-Speed Tripping (87L, 21), MIRRORED BITS Communications, and High-Speed Open-Pole Detection in the SEL-411L Relay Provides for Faster Total Clearing Time

Breaker Failure Protection

With the SEL-411L, you can monitor current individually in two breakers (see *Figure 20*). Single- and three-pole logic allows flexible operation. High-speed open-pole detection logic allows you to set the pickup current below minimum load, so you obtain dependability of the BF protection without the need to increase time co-ordination margins. Even in cases in which trapped flux causes delayed current zero in the secondary of the CT, you can achieve high-speed detection of circuit breaker opening. This feature is essential if the breaker failure element initiates on all circuit breaker trips. A 5/8-cycle reset reduces security margin requirements, improving power system dynamic stability.

Thermal Overload Protection

The SEL-411L supports three independent thermal elements that conform to the IEC 60255-149 standard. Use these elements to activate a control action or issue an alarm or trip when your equipment overheats as a result of adverse operating conditions.

The SEL-2600 RTD Module provides ambient temperature measurements for the thermal model.

The SEL-411L provides you the ability to select one of two different algorithms for out-of-step detection. One of the two

LOP Logic Supervises Directional Elements

The SEL-411L includes logic to detect an LOP resulting from such failures as blown fuses, which can cause incorrect operation in distance and directional elements or prevent application of line-charging current compensation. Simple settings configure the LOP logic to either block or force forward ground and phase directional elements under these conditions. The line-charging current compensation logic adapts to the LOP conditions and includes a fallback should there be a loss of all voltage sources. The LOP logic checks for a sudden change in positive-sequence voltage without a corresponding change in positive- or zero-sequence current. Tests and field experience show that this principle is secure and faster than the supervised tripping elements.

Out-of-Step Detection

Use out-of-step detection to secure the distance elements during power swings, which must be set to encompass the distance elements. Such detection logic declares a power swing when an impedance locus travels through the blinders slower than a preset rate.

schemes may be selected by the user.

With the zero setting method, there is no need for either system studies or settings (other than enabling) for out-of-step functions. If you use local voltage measurements (see *Figure 21*) to closely approximate the swing center voltage

(SCV), the relay can use the rate-of-SCV change to quantify the power swing condition. For either method, the system provides verified performance for in-zone and out-of-zone fault conditions and all normal power swings.

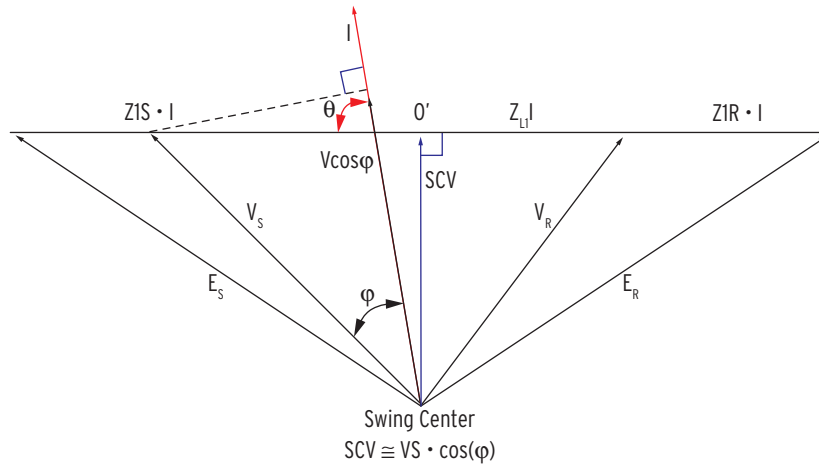

Figure 21 Applying V_S to Approximate the Swing Center Voltage Provides an Accurate Local Quantity to Detect Power Swings

Six Independent Settings Groups Increase Operation Flexibility

The relay stores six settings groups. Select the active settings group by control input, command, or other programmable conditions. Use these settings groups to cover a wide range of protection and control contingencies. Selectable settings groups make the SEL-411L ideal for applications requiring frequent settings changes and for adapting the protection to changing system conditions. In addition to the setting groups, the 87L elements incorporate normal and expanded security settings within each setting group to cope with conditions that potentially put the 87L elements in danger. This includes degraded or lost charging current compensation, degraded or lost time reference, etc. as well as user-programmable conditions.

Selecting a group also selects logic settings. Program group logic to adjust settings for such different operating conditions as station maintenance, seasonal operations, emergency contingencies, loading, source changes, and adjacent relay settings changes.

Combined Current for Protection Flexibility

For traditional relays, when protecting a line fed from two breakers, such as a breaker-and-a-half system or double-breaker system, you needed to parallel the CTs before connecting these inputs to the relay. The SEL-411L accepts separate inputs from two separate CTs and combines the currents mathematically. You can collect separate current metering and breaker monitor information for each breaker and provide breaker failure functions on a per-breaker basis. Breaker diagnostic reports from the SEL-411L provide you comparative breaker information that you can use for advanced, proactive troubleshooting.

Control Inputs and Outputs

The SEL-411L includes positions for as many as three I/O boards. You can select these in the following configurations:

- ▶ Eight optoisolated, independent level-sensitive inputs; 13 standard Form A and two standard Form C contact outputs
- ▶ Eight optoisolated, independent level-sensitive inputs; 13 high-current interrupting Form A outputs and two Standard Form C contact outputs
- ▶ Twenty-four optoisolated, independent level-sensitive inputs; six high-speed, high-current interrupting, polarity dependent Form A contact outputs and two standard Form A outputs
- ▶ Twenty-four optoisolated, independent level-sensitive inputs; eight standard Form A outputs
- ▶ Twenty-four optoisolated, independent level-sensitive inputs; eight high-speed, high-current interrupting, polarity dependent Form A contact outputs

Assign the control inputs for control functions, monitoring logic, and general indication. You can use SELOGIC control equations to program each control output. You can add one I/O board to the 4U chassis, two I/O boards to the 5U chassis, and as many as three I/O boards to the 6U chassis. All control inputs are optoisolated.

Multifunction Recloser With Flexible Applications

The SEL-411L includes both single-pole and three-pole trip and reclose functions for either one or two breakers (*Figure 22*). You can use synchronism check to provide breaker control. To minimize system stress upon reclosing, you can use dead line/dead bus closing logic and zero-closing-angle logic to program synchronizing and polarizing voltage inputs. Program as many as two single-pole reclose

attempts, four three-pole reclose attempts, and combined single-/three-pole reclosing sequences. Select leader and follower breakers directly, or use a SELOGIC control equation to determine reclosing order based on system conditions. Coupled with independent-pole-operating circuit breakers, this reclosing system gives maximum flexibility for present system conditions and for future requirements.

Alternate Voltage Option

A relay-detected LOP condition can initiate a transfer of voltage inputs to another voltage source connected to the relay. The logic maintains normal protection operation of all directional elements in the relay with the LOP condition. You can program an LOP alarm contact to alert an operator to a system error, allowing the operator to find and repair the faulty element.

Two-Breaker Control

The SEL-411L contains analog voltage inputs for multiple sources and control inputs. These voltage inputs indicate both breaker and disconnect position, as well as the logic necessary to provide full control for two breakers. This includes separate monitoring functions and separate elements for tripping and closing the two breakers to allow for leader/follower operation or other necessary control schemes. The SEL-411L monitors all analog values on a per-breaker basis, providing station control access to complete information for individual system components.

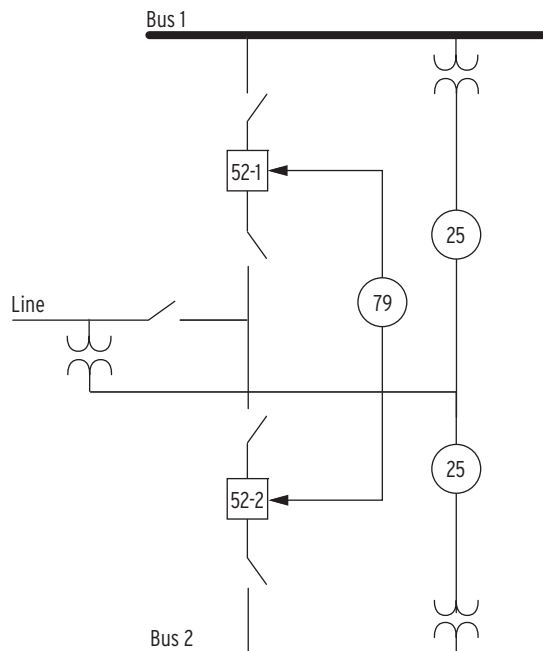

Figure 22 Two-Breaker Reclosing With Synchronism Check

Voltage Elements

The SEL-411L provides six independent over- and undervoltage elements, each with two pickup levels. The first pickup level includes a definite-time delay. Choose from a wide range of fundamental and rms operating quantities for the Y and Z terminal voltage inputs. Table 2 shows the voltage inputs available for use as operating quantities.

Table 2 Voltage Element Operating Quantities

Analog Quantity	Description
VA, VB, VC	L-N Phase Voltage
VNMAX, VNMIN	Neutral Voltage Min/Max
VAB, VBC, VCA	L-L Phase Voltage
VA-VN ^a , VB-VN ^a , VC-VN ^a	Phase Voltage with Neutral Voltage Subtracted
VPMAX, VPMIN	Phase Voltage Min/Max
V1 ^a , 3V2 ^a , 3V0 ^a	Positive-, Negative-, Zero-Sequence

^a Fundamental quantities only.

Frequency Elements

The SEL-411L provides six frequency elements, each driven from either the Y or the Z potential transformers. You can configure any of the six elements for over- or under-frequency. Each frequency element provides a pickup time-delay setting. A programmable undervoltage element supervises the frequency elements. You can set the undervoltage element to monitor either Y or Z potential inputs and to block assertion of the 81 element when the selected voltage input falls below a programmable undervoltage supervision threshold.

Communications Overview

The SEL-411L relay contains communication options for multiple applications.

- **87L Communications Options:** Two channels using 1550 nm, 1300 nm, 1300 nm IEEE C37.94, 850 nm IEEE C37.94, EIA-422, or G.703 for line current differential protection. Optionally, line current differential protection can be implemented using Ethernet.
- **Automation or Synchrophasors Over Ethernet:** As many as four Ethernet ports for IEC 61850, C37.118 Synchrophasors, DNP LAN/WAN, or other Ethernet communications.
- **Serial Communication:** Four (three rear and one front) EIA-232 serial ports for local access, MIRRORED BITS communications, integration with SEL communications processors, or other serial applications (excluding 87L functions).

Serial Communication

The SEL-411L offers the following serial communications features in addition to the dedicated 87L ports:

- Four independent EIA-232 serial ports.
- Full access to event history, relay status, and meter information.

- Settings and group switching have strong password protection.
- Patented SEL MIRRORED BITS communications technology provides bidirectional relay-to-relay digital communications. In the SEL-411L, MIRRORED BITS communications can operate simultaneously on any two serial ports for three-terminal power system operation.
- DNP3 Level 2 Outstation
- Patented SEL Fast Message interleaving of ASCII and binary data for supervisory control and data acquisition (SCADA) communication, including access to SER, relay element targets, event data, and more.
- Communication of synchronized phasor-measurement data through the use of either SEL Fast Messaging for Synchrophasors or IEEE C37.118-2005, *Standard for Synchrophasors for Power Systems*.
- Four EIA-232 Serial Ports for local access, MIRRORED BITS communications, integration with SEL communications processors, or other serial applications.

In addition, an IRIG-B time code input is available for accurate time-stamping.

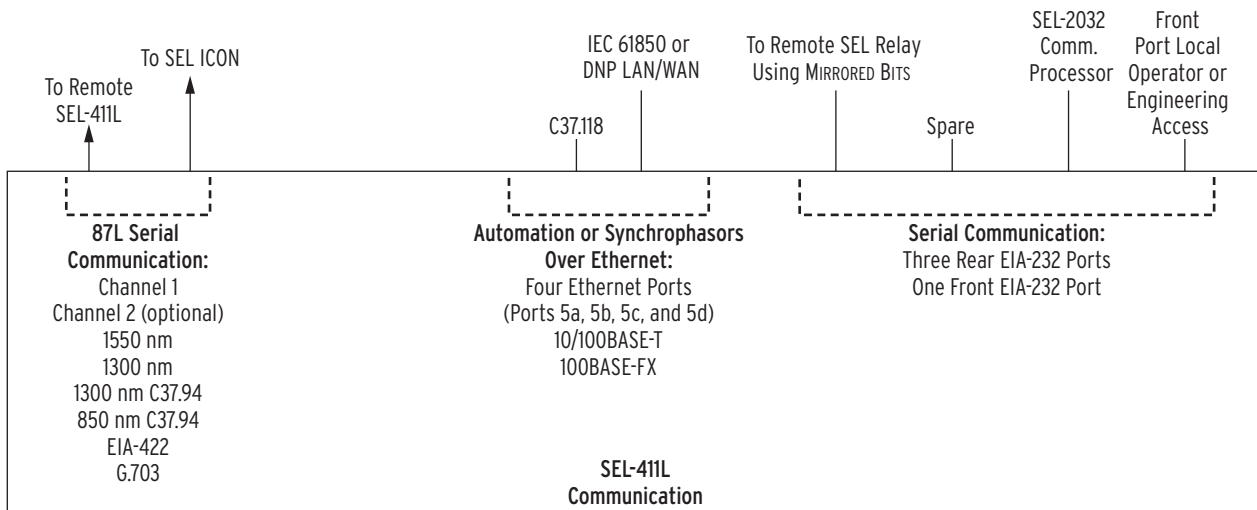

Figure 23 System Functional Overview

Ethernet Card

The optional Ethernet card provides as many as four Ethernet ports. Use popular Telnet applications for easy terminal communications with SEL relays and other devices. Transfer data at high speeds (10 Mbps or 100 Mbps) for fast HMI updates and file uploads. The Ethernet card communicates through the use of File Transfer Protocol (FTP) applications, for easy and fast file transfers.

Use IEEE C37.118-2005 Standard for Synchrophasors for Power Systems to provide operators with situational awareness of the power system. Use IEC 61850 MMS and

GOOSE messaging to communicate with SCADA and other substation intelligent electronic devices (IEDs). The DNP3 LAN/WAN option provides the SEL-411L with DNP3 Level 2 slave functionality over Ethernet. You can configure custom DNP3 data maps for use with specific DNP3 masters.

Choose Ethernet connection media options for primary and stand-by connections:

- 10/100BASE-T Twisted Pair Network
- 100BASE-FX Fiber-Optic Network

Precision Time Protocol (PTP)

Using Ports 5A and 5B, the SEL-411L has the ability to accept IEEE 1588 Precision Time Protocol, version 2 (PTPv2) for data time synchronization. Optional PTP support includes both the Default and Power System (C37.238-2011) PTP Profiles.

IEC 61850 Ethernet Communications

IEC 61850 Ethernet-based communications provide interoperability among intelligent devices within the substation. Logical nodes using IEC 61850 allow standardized interconnection of intelligent devices from different manufacturers for monitoring and control of the substation. Reduce wiring among various manufacturers' devices and simplify operating logic with IEC 61850.

Eliminate system RTUs by streaming monitoring and control information from the intelligent devices directly to remote SCADA client devices.

You can order the SEL-411L with optional IEC 61850 protocols operating on 10/100 Mbps Ethernet. IEC 61850 protocols provide relay monitoring and control functions including:

- As many as 128 incoming GOOSE messages. The incoming GOOSE messages can be used to control as many as 256 control bits in the relay with <3 ms latency from device to device. These messages provide binary control inputs and analog values to the relay for high-speed control functions and monitoring.
- As many as eight outgoing GOOSE messages. You can configure outgoing GOOSE messages for Boolean or analog data. Boolean data and designated remote analog outputs are provided with <3 ms latency from device to device. Apply outgoing GOOSE messages for high-speed control and monitoring of external breakers, switches, and other devices.
- Isolated IP Mode. The relay shall include an isolated IP Mode that permits IEC 61850 GOOSE messages on two ports but restricts IP traffic to just one port.
- IEC 61850 Data Server. The SEL-411L, equipped with embedded IEC 61850 Ethernet protocol, provides data according to predefined logical node objects. Each relay supports as many as seven simultaneous client associations. Relevant Relay Word

bits are available within the logical node data, so you can use the IEC 61850 data server in the relay to monitor the status of relay elements, inputs, outputs, or SELOGIC control equations.

- Configuration of as many as 256 Virtual Bits within GOOSE messaging to represent a variety of Boolean values available within the relay. The Virtual Bits the relay receives are available for use in SELOGIC control equations.
- As many as 64 Remote analog outputs that you can assign to virtually any analog quantity available in the relay. You can also use SELOGIC math variables to develop custom analog quantities for assignment as remote analog outputs. Remote analog outputs using IEC 61850 provide peer-to-peer transmission of analog data. Each relay can receive as many as 256 remote analog inputs and use those inputs as analog quantities within SELOGIC control equations.

Use ACSELERATOR Architect[®] SEL-5032 Software to manage the logical node data for all IEC 61850 devices on the network. This Microsoft[®] Windows[®]-based software provides easy-to-use displays for identifying and binding IEC 61850 network data among logical nodes using IEC 61850-compliant Configured IED Description (CID) files. Architect uses CID files to describe the data in the IEC 61850 logical nodes provided within each relay.

Telnet and FTP

Order the SEL-411L with Ethernet communications and use the built-in Telnet and File Transfer Protocol (FTP) that come standard with Ethernet to enhance relay communications sessions. Use Telnet with the ASCII interface to access relay settings, and metering and event reports remotely.

Parallel Redundancy Protocol (PRP)

The optional Ethernet card can operate in Parallel Redundancy Protocol (PRP) mode. This protocol is used to provide seamless recovery from any single Ethernet network failure, in accordance with IEC 62439-3. The Ethernet network and all traffic are fully duplicated with both copies operating in parallel.

Use FTP to transfer settings files to and from the relay via the high-speed Ethernet port.

Metering and Monitoring

Metering Capabilities

The SEL-411L provides extensive metering capabilities as listed in *Table 3*.

Table 3 Metering Capabilities

Capabilities		Description
Instantaneous Quantities		
Voltages	$V_{A,B,C} (Y), V_{A,B,C} (Z), V_{\phi\phi}, 3V_0, V_1, 3V_2$	0–300 V with phase quantities for each of the six voltage sources available as separate quantities.
Currents (local, remote, and differential)	$I_{A,B,C}, I_1, 3I_2, 3I_0$	Individual phase and sequence currents for local, remote relay terminal, and differential currents.
Currents	$I_{A,B,C} (W), I_{A,B,C} (X), I_{AL}, I_{BL}, I_{CL},$ (combined currents), $I_{GL}, I_{LL}, 3I_{2L}$ (combined currents)	Phase quantities for each of the two current sources available as separate quantities or combined as line quantities.
Power/Energy Metering Quantities		
MW, MWh, MVAR, MVARh, MVA, PF, single phase and three phase		Available for each input set and as combined quantities for the line.
Demand/Peak Demand Metering		
$I_{A,B,C}, 3I_2, 3I_0$		Thermal or rolling interval demand and peak demand.
MW, MVAR, MVA, single phase		Thermal or rolling interval demand and peak demand.
MW, MVAR, MVA, three phase		Thermal or rolling interval demand and peak demand.

Event Reporting and Sequential Events Recorder (SER)

Event reports and SER features simplify post-fault analysis and help improve your understanding of protective scheme operations. These features also aid in testing and troubleshooting relay settings and protection schemes. Oscillograms are available in binary COMTRADE and ASCII formats.

Oscillography and Event Reporting

In response to a user-selected internal or external trigger, the relay captures data about an event or fault condition. The captured data are available in binary COMTRADE and ASCII (ASCII text).

The COMTRADE file contains all local data such as voltage, current and element status. Choose a resolution for analog data in the COMTRADE file of 8, 4, 2, or 1 kHz. The relay can store three seconds of data at a sampling rate of 8 kHz and 24 seconds of data at a sampling rate of 1 kHz.

The ASCII data file contains not only all the local voltages and currents but also all the remote currents. The file contains both the instantaneous local currents and the aligned local currents. The aligned local and remote currents are the currents the 87L functions use. You can use the aligned currents to verify the operation of the 87L elements and the entire differential scheme. The ASCII data are available at resolutions of eight or four samples per power system cycle.

Event Summary

Each time the SEL-411L generates a standard event report, it also generates a corresponding event summary. This is a concise description of an event that includes the following information:

- Relay/terminal identification
- Event date and time
- Event type
- Fault location
- Recloser shot count at time of trigger
- System frequency at time of trigger
- Phase voltages
- Fault type at time of trip
- Prefault, fault phase, and polarizing current levels
- Prefault and fault calculated zero- and negative-sequence currents
- Active group targets
- Status of all MIRRORING BITS communications channels
- Trip and close times of day
- Breaker status (open/close)

With an appropriate setting, the relay will automatically send an event summary in ASCII text to one or more serial ports for each event report.

Sequential Events Recorder (SER)

Use this feature to gain a broad perspective of relay element operation. You can select the items that trigger an SER entry. These include input/output change of state, element pickup/dropout, recloser state changes, etc. The relay SER stores the latest 1,000 entries.

Precision Time Protocol (PTP) Time Synchronization

In addition to being able to use IRIG-B for high-accuracy timekeeping, the relay can use IEEE 1588 Precision Time Protocol, version 2 (PTPv2) to obtain time synchronization through the Ethernet network. When connected directly to a grandmaster clock providing PTP at 1-second synchronization intervals, in the PTP timescale the relay can be synchronized to an accuracy of ± 100 ns. The relay can receive as many as 32 synchronization messages per second.

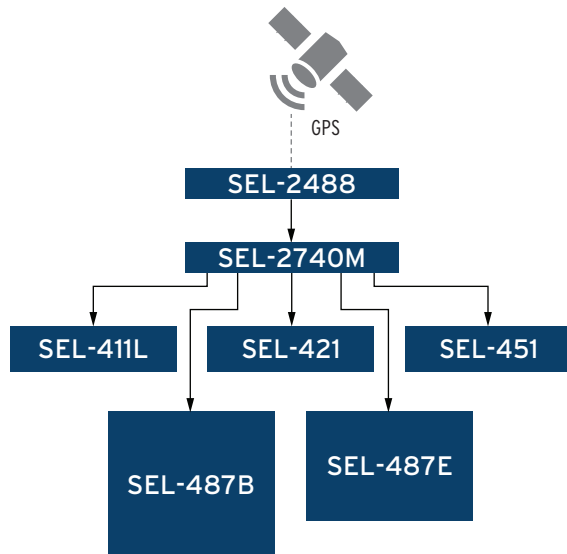

Figure 24 Example PTP Network

High-Accuracy Time Keeping

Using high-accuracy IRIG-B from a global positioning satellite clock or the SEL ICON system, the SEL-411L can time-tag oscillography to within $10 \mu\text{s}$ accuracy.

A high-accuracy C37.118 IRIG-B time-code input synchronizes the SEL-411L time to be within $\pm 1 \mu\text{s}$ of the time-source input when the time-source input jitter is less than 500 ns and the time error is less than $1 \mu\text{s}$. A convenient source for this time code is an SEL communications processor (via Serial Port 1 on the SEL-411L). You can combine this high accuracy with the high sampling rate of the relay to synchronize data from across the system with an accuracy of better than $1/4$ electrical degree. You can then examine the states of such power system components and system-wide events as load angles and system swings. You can cause triggering via an external signal (contact or communications port), set time, or

system event. Optimal calibration of this feature requires knowledge of primary input component (VT and CT) phase delay and error.

The SEL-411L uses external time-based synchronization to allow 87L applications over asymmetrical channels. Such applications with SEL-411L relays connected to asymmetrical channels, require high-precision time sources. The SEL-411L provides for fallback logic in the case of lost or degraded time sources.

Traveling Wave Fault Location

When high-accuracy IRIG-B time is available, the SEL-411L uses a type D traveling wave (TW) algorithm to compute fault location. A dedicated analog-to-digital converter samples both sets of three-phase currents connected to the relay terminals (IAW, IBW, ICW, IAX, IBX, ICX) at 1.5625 MHz. Each SEL-411L in a two-terminal scheme extracts high frequency content and, based on a setting selection, uses one set of three-phase currents for fault location calculation. When an 87L or communications-assisted trip occurs, each relay terminal exchanges data along with a time stamp, and the SEL-411L relays then use this information to calculate a fault location. Figure 25 shows the traveling waves captured at each terminal.

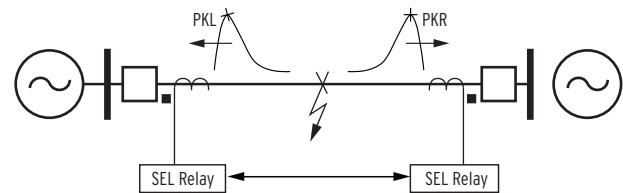

Figure 25 Relays Exchanging Peak Information Via 87L Communications Channel

In installations where the differential communications channel is not available, an SEL-411L can compute fault location manually by using the traveling wave COMTRADE files it retrieves from either terminal.

The SEL-411L displays all fault location estimates (traveling wave and one impedance-based).

Substation Battery Monitor for DC Quality Assurance

The SEL-411L measures and reports substation battery voltage for two battery systems. Two sets of programmable threshold comparators and associated logic provide alarm and control of two separate batteries and chargers. The relay also provides dual ground detection. Monitor these thresholds with an SEL communications processor and trigger messages, telephone calls, or other actions when necessary.

Obtain measured dc voltage information in the METER display via serial port communications, on the LCD, and in the event report. Use event report data to see an oscillographic display of the battery voltage. Monitor substation battery voltage drops during trip, close, and other control operations.

Breaker Monitor Feature Allows for Wear-Based Breaker Maintenance Scheduling

Circuit breakers experience mechanical and electrical wear during each operation. Effective scheduling of breaker maintenance takes into account the manufacturer's published data of contact wear versus interruption levels and operation count. The SEL-411L dual breaker monitor feature compares the breaker manufacturer's published data to the integrated actual interrupted current and number of operations.

- Every time the breaker trips, the relay integrates interrupted current. When the result of this integration exceeds the threshold set by the breaker wear curve (Figure 26), the relay can alarm via an output contact or the optional front-panel display. With this information, you can schedule breaker maintenance in a timely, economical fashion.

- The relay monitors last and average mechanical and electrical interruption time per pole. You can easily determine if operating time is increasing beyond reasonable tolerance and then schedule proactive breaker maintenance. You can activate an alarm point if operation time exceeds a preset value.

The SEL-411L also monitors breaker motor run time, pole scatter, pole discrepancy, and breaker inactivity.

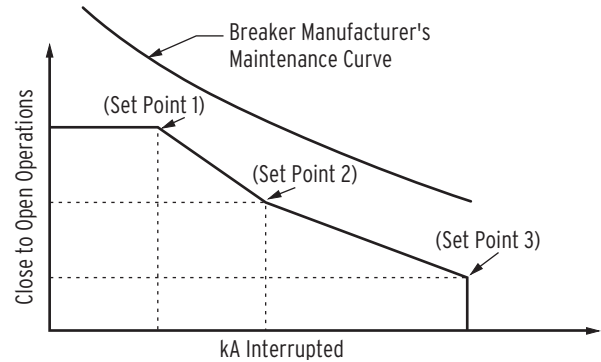

Figure 26 Breaker Contact Wear Curve and Settings

Automation

Flexible Control Logic and Integration Features

Use the SEL-411L control logic to do the following:

- Replace traditional panel control switches
- Eliminate RTU-to-relay wiring
- Replace traditional latching relays
- Replace traditional indicating panel lights

Eliminate traditional panel control switches with 32 local control points. Set, clear, or pulse local control points with the front-panel pushbuttons and display. Program the local control points to implement your control scheme via SELOGIC control equations. Use the local control points for such functions as trip testing, enabling/disabling reclosing, and tripping/closing circuit breakers.

Eliminate RTU-to-relay wiring with 32 remote control points. Set, clear, or pulse remote control points via serial port commands. Incorporate the remote control points into your control scheme via SELOGIC control equations. Use remote control points for SCADA-type control operations (e.g., trip, close, settings group selection).

Replace traditional latching relays for such functions as "remote control enable" with 32 latching control points. Program latch set and latch reset conditions with SELOGIC control equations. Set or reset the latch control points via control inputs, remote control points, local control points, or any programmable logic condition. The latch control points retain states when the relay loses power.

Replace traditional indicating panel lights and switches with as many as 24 latching target LEDs and as many as 12 programmable pushbuttons with LEDs. Define custom messages (i.e., BREAKER OPEN, BREAKER CLOSED, RECLOSER ENABLED) to report power system or relay conditions on the large format LCD. Control which messages display via SELOGIC control equations by driving the LCD display via any logic point in the relay.

Open Communications Protocols

The SEL-411L requires no special communications software. You need only ASCII terminals, printing terminals, or a computer supplied with terminal emulation and a serial communications port for the SEL-411L. Table 4 lists a synopsis of the terminal protocols.

Table 4 Open Communications Protocol (Sheet 1 of 2)

Type	Description
ASCII	Plain-language commands for human and simple machine communications. Use for metering, setting, self-test status, event reporting, and other functions.
Compressed ASCII	Comma-delimited ASCII data reports. Allows external devices to obtain relay data in an appropriate format for direct import into spreadsheets and database programs. Data are checksum protected.

Table 4 Open Communications Protocol (Sheet 2 of 2)

Type	Description
Extended Fast Meter, Fast Operate, and Fast SER	Binary protocol for machine-to-machine communication. Quickly updates SEL-2032 Communications Processors, RTUs, and other substation devices with metering information, relay element, I/O status, time-tags, open and close commands, and summary event reports. Data are checksum protected. Binary and ASCII protocols operate simultaneously over the same communications lines so that control operator metering information is not lost while a technician is transferring an event report.
Ymodem	Support for reading event, settings, and oscillography files.
Optional DNP3 Level 2 Outstation	Distributed Network Protocol with point remapping. Includes access to metering data, protection elements, contact I/O, targets, SER, relay summary event reports, and settings groups.
IEEE C37.118	Phasor measurement protocol.
IEC 61850	Ethernet-based international standard for interoperability among intelligent devices in a substation.

Rules-Based Settings Editor

Use QuickSet to develop settings off-line. The system automatically checks interrelated settings and highlights out-of-range settings. You can transfer settings that you created off-line by using a PC communications link with the SEL-411L. The relay converts event reports to oscillograms with time-coordinated element assertion and phasor/sequence element diagrams. The QuickSet interface supports Windows 7 32-bit and 64-bit, Windows 8, and Windows Server 2008 operating systems. Open COMTRADE files from SEL and other products. Convert binary COMTRADE files to ASCII format for portability and ease of use. Use QuickSet to convert oscillographic data to phasor data and to calculate the harmonic content of the captured data.

ACSELERATOR QuickSet SEL-5030 Software

Use licensed versions of QuickSet to create custom views of settings, called Design Templates, to reduce complexity, decrease the chance of errors, and increase productivity:

- Lock and hide unused settings.
- Lock settings to match your standard for protection, I/O assignment, communication, and SELOGIC control equations.

- Enforce settings limits narrower than the device settings.
- Define input variables based on the equipment name-plate or manufacturer's terminology or scaling and calculate settings from these "friendlier" inputs.
- Use settings comments to guide users and explain design reasoning.

SELogIC Control Equations With Expanded Capabilities and Aliases

Expanded SELOGIC control equations put relay logic in the hands of the protection engineer. Assign the relay inputs to suit your application, logically combine selected relay elements for various control functions, and assign outputs to your logic functions.

Programming SELOGIC control equations consists of combining relay elements, inputs, and outputs with SELOGIC control equation operators (*Table 5*). You can use any element in the Relay Word in these equations. The SEL-411L is factory set for use without additional logic in most situations. For complex or unique applications, these expanded SELOGIC functions allow superior flexibility.

Table 5 SELogIC Control Equation Operators

Operator Type	Operators	Comments
Boolean	AND, OR, NOT	Allows combination of measuring units.
Edge Detection	F_TRIG, R_TRIG	Operates at the change of state of an internal function.
Comparison	>, >=, =, <=, <, <>	
Arithmetic	+, -, *, /	Uses traditional math functions for analog quantities in an easily programmable equation.
Numerical	ABS, SIN, COS, LN, EXP, SQRT	
Precedence Control	()	Allows multiple and nested sets of parentheses.
Comment	#	Provides for easy documentation of control and protection logic.

Use the new alias capability to assign more meaningful relay variable names. This improves the readability of customized programming. Use as many as 200 aliases to rename any

digital or analog quantity. The following is an example of possible applications of SELOGIC control equations using aliases.

```

=>>SET T <Enter>
1: PMV01, THETA
(assign the alias "THETA" to math variable PMV01)
2: PMV02, TAN
(assign the alias "TAN" to math variable PMV02)
=>>SET L <Enter>
1: # CALCULATE THE TANGENT OF THETA
2: TAN:=SIN(THETA)/COS(THETA)
(use the aliases in an equation)

```

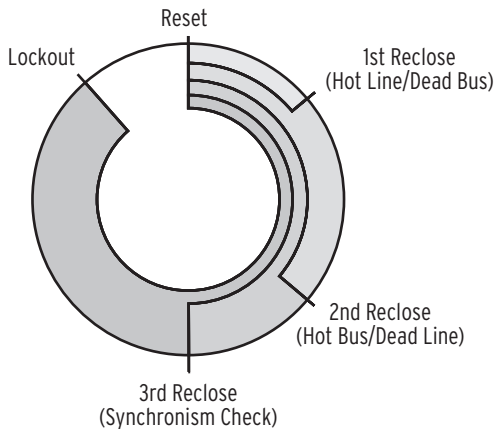

Figure 27 Motor-Driven Reclose Timer

Add programmable control functions to your protection and automation systems. New functions and capabilities enable the use of analog values in conditional logic statements. The following are examples of possible applications of SELOGIC control equations with expanded capabilities:

- Emulate a motor-driven reclose timer, including stall, reset, and drive-to-lockout conditions (refer to *Figure 27*).
- Scale analog values for SCADA retrieval.
- Initiate remedial action sequence based on load flow before fault conditions.
- Interlock breakers and disconnect switches.
- Restrict breaker tripping in excessive duty situations without additional relays.
- Construct a compensated overvoltage element for open line overvoltage protection.
- Hold momentary change-of-state conditions for SCADA polling.
- Provide a combination of frequency or rate of change of frequency functions.

Advanced Front-Panel Operation

Front-Panel Display

The liquid crystal display (LCD) shows event, metering, setting, and relay self-test status information. The target light-emitting diodes (LEDs) display relay target information as shown in *Figure 28*.

Control of the LCD comes from the navigation pushbuttons (*Figure 29*), automatic messages the relay generates, and user-programmed analog and digital display points. The rotating display scrolls through alarm points, display points, and metering screens. If none are active, the relay scrolls through displays of the fundamental and rms metering screens. Each display remains for a user-programmed time (1–15 seconds) before the display continues scrolling. Any message the relay generates because of an alarm condition takes precedence over the rotating display.

Figure 28 and *Figure 29* show close-up views of the front panel of the SEL-411L. The front panel includes a 128 x 128 pixel, 3" x 3" LCD screen; LED target indicators; and pushbuttons with indicating LEDs for local control functions. The asserted and deasserted colors for the LEDs are

programmable. Configure any of the direct-acting pushbuttons to navigate directly to any HMI menu item for fast viewing of events, alarm points, display points, or the SER.

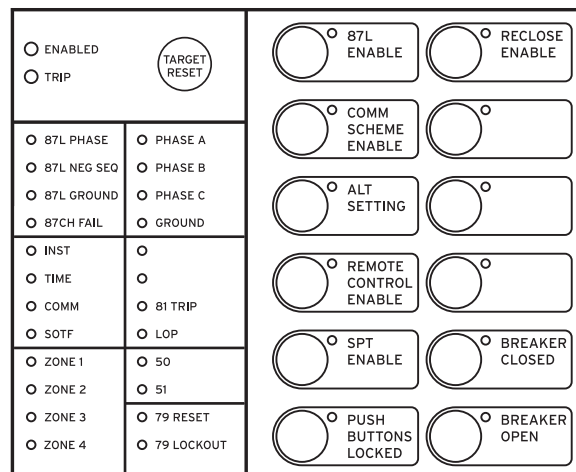

Figure 28 Factory Default Status and Trip Target LEDs (12 Pushbutton, 24 Target LED Option)

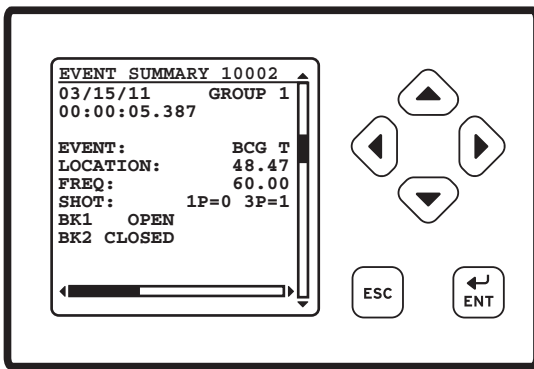

Figure 29 Factory-Default Front-Panel Display and Pushbuttons

Bay Control

The SEL-411L provides dynamic bay one-line diagrams on the front-panel screen with disconnect and breaker control capabilities for 25 predefined user-selectable bay types. You can download the QuickSet interface from selinc.com to obtain additional user-selectable bay types. The bay control can control as many as 10 disconnects and two breakers, depending on the one-line diagram you select. Certain one-line diagrams provide status for as many as three breakers and five disconnect switches. Operate disconnects and breakers with ASCII commands, SELOGIC control equations, Fast Operate Messages, and from the one-line diagram. The one-line diagram includes user-configurable apparatus labels and as many as six user-definable analog quantities.

One-Line Bay Diagrams

The SEL-411L bay control offers a variety of preconfigured one-line diagrams for common bus configurations. Once you select a one-line diagram you can customize the names for all of the breakers, disconnect switches, and buses. Most one-line diagrams contain analog display points. You can set these display points to any of the available analog quantities (including remote 87L currents) with labels, units, and scaling. The SEL-411L updates these values along with the breakers and switch position in real time to give instant status and complete control of a bay. The following diagrams demonstrate some of the preconfigured bay arrangements available in the SEL-411L.

Operators can see all valuable information on a bay before making critical control decisions. Programmable interlocks help prevent operators from incorrectly opening or closing switches or breakers. The SEL-411L will not only prevent operators from making an incorrect control decision, but it can notify and/or alarm upon initiation of an incorrect operation.

Circuit Breaker Operations From the Front Panel

Figure 30 and Figure 31 are examples of some of the selectable one-line diagrams in the SEL-411L. Select the one-line diagram from the Bay settings.

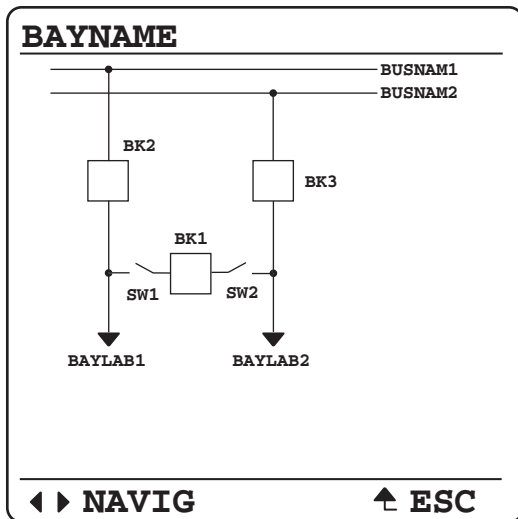

Figure 30 Breaker-and-a-Half

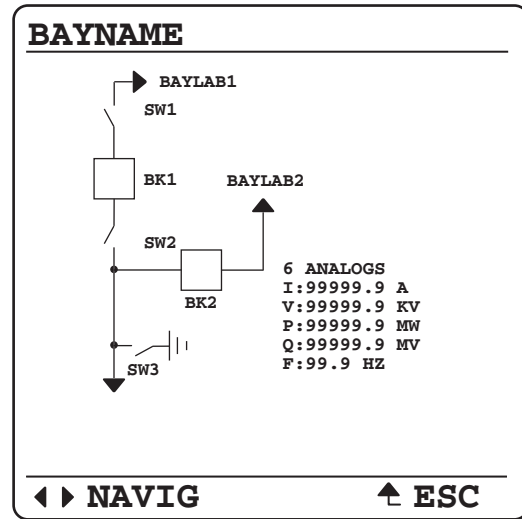

Figure 31 Ring Bus With Ground Switch

Status and Trip Target LEDs

The SEL-411L includes programmable status and trip target LEDs, as well as programmable direct-action control pushbuttons on the front panel. Figure 28 shows these targets.

The SEL-411L features a versatile front panel that you can customize to fit your needs. Use SELOGIC control equations and slide-in configurable front-panel labels to change the

function and identification of target LEDs and operator control pushbuttons and LEDs. The blank slide-in label set is included with the SEL-411L. Configuration of functions is simple through use of QuickSet. You can use templates supplied with the relay or hand label supplied blank labels and print label sets from a printer.

Alarm Points

You can display messages on the SEL-411L front-panel LCD that indicate alarm conditions in the power system. The relay uses alarm points to place these messages on the LCD.

Figure 32 shows a sample alarm points screen. The relay can display as many as 66 alarm points. The relay automatically displays new alarm points while in manual-scrolling mode and in auto-scrolling mode. You can configure the alarm points message and trigger it either immediately through use of inputs, communications, and the SEL-2600 or conditionally through use of powerful SELOGIC control equations. The asterisk next to the alarm point indicates an active alarm. Use the front-panel navigation pushbuttons to clear inactive alarms.

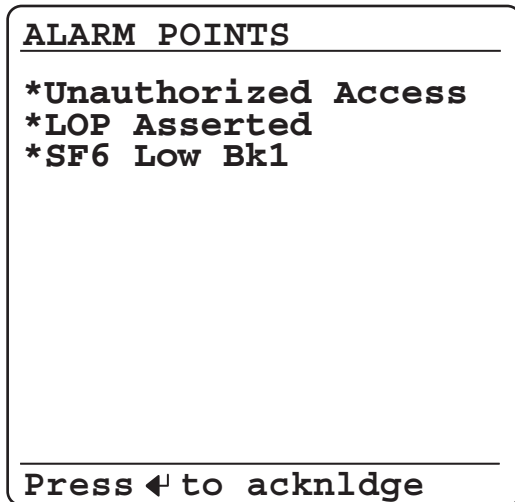

Figure 32 Sample Alarm Points Screen

Advanced Display Points

Create custom screens showing metering values, special text messages, or a mix of analog and status information. Figure 33 shows an example of how you can use display points to show circuit breaker information and current metering. You can create as many as 96 display points. All display points occupy one, and only one, line on the display at all times. The height of the line is programmable as either single or double, as Figure 33 shows. These screens become part of the auto-scrolling display when the front panel times out.

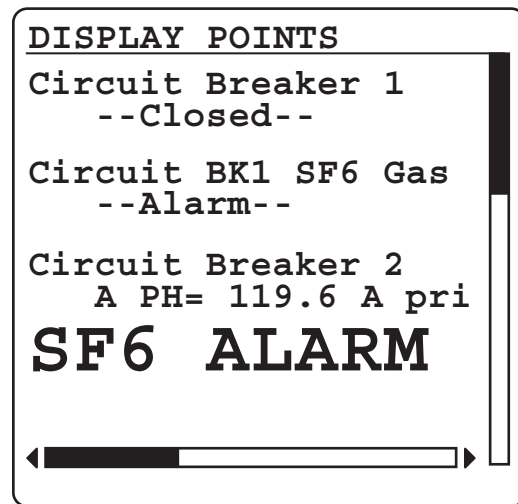

Figure 33 Sample Display Points Screen

Application Examples

The SEL-411L allows applications of the 87L function in one of several configurations, for which you can provide control through use of the E87CH (Enable 87 Channel) or 87PCH (87 Primary Channel) settings.

Two-Terminal Application With a Dual Serial Channel (E87CH = 2SD)

Set E87CH = 2SD when two communications channels are available. Figure 34 shows an application consisting of two SEL-411LL relays, each having two serial 87L ports that are connected through the use of two serial channels. This application provides for channel redundancy through the use of channel switch-over logic. The 87PCH setting controls which channel is the primary channel (i.e., the channel the SEL-411L uses for the 87L function if both channels are available and of equal quality). The primary channel can be direct point-to-point fiber, and the secondary channel can be a multiplexed channel.

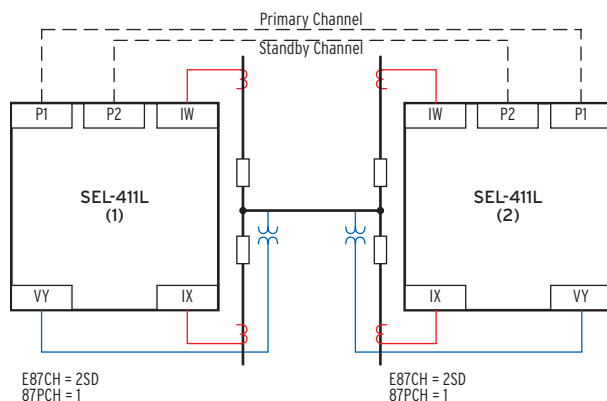

Figure 34 Two-Terminal 2SD Configuration With Both Line Ends Terminated on Dual-Breaker Buses and Port 1 Configured as Primary

Three-Terminal Master Application With Serial Channels (E87CH = 3SM)

Figure 35 shows an SEL-411L set to 3SM, in which the relay uses two serial channels to communicate with two remote peers in a three-terminal application. If two channels are installed, connecting each relay with both of its remote peers, all relays are set to E87CH = 3SM.

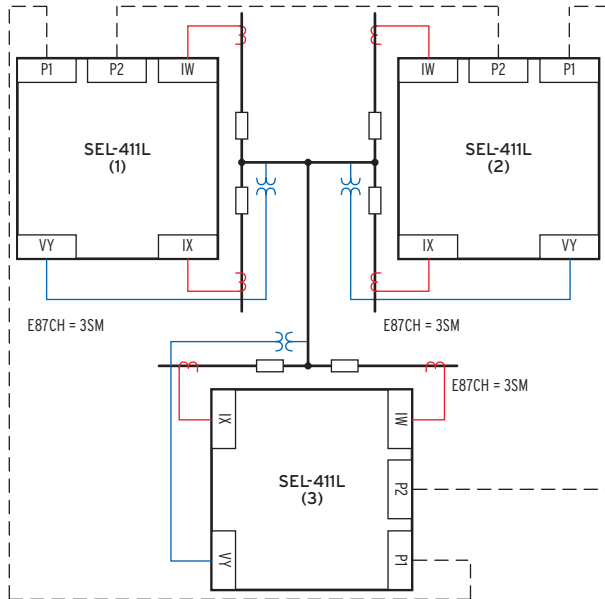

Figure 35 Three-Terminal 3SM Configuration With All Relays as Masters

Three-Terminal Slave Application With a Serial Channel (E87CH = 3SS)

Figure 36 shows a SEL-411L set to 3SS, in which the relay uses one serial channel to communicate with one remote peer in a three-terminal application. This relay acts as a slave serving the data to the connected master (relay set to E87CH = 3SM), but it does not receive data from any remote peers and cannot perform differential protection independently. Slave relays trip via the 87DTT (direct transfer trip) bit they receive from the master(s). An operational 87L scheme requires that at least one relay be a master and that a bidirectional communications channel exists between the master and each slave.

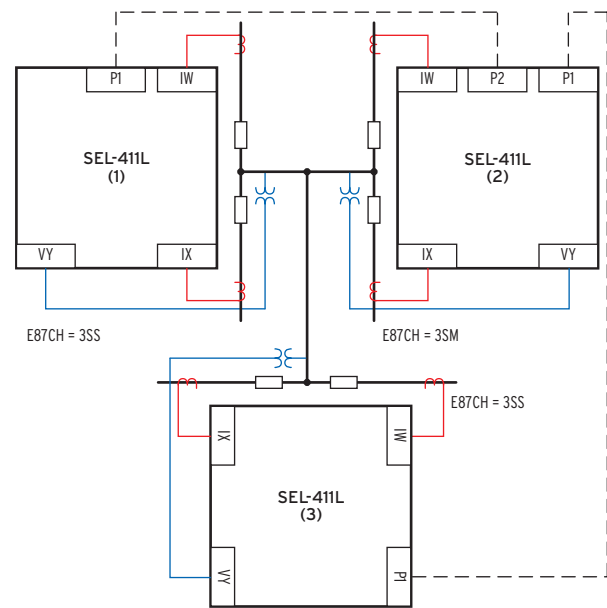

Figure 36 Three-Terminal Application Over Serial Channels With Relay 1 and Relay 3 as Slaves

In-Line Transformers

For lines with transformers, the preferred application is to apply separate relays for the line current differential zone and the transformer differential zone, as shown in Figure 37. This allows application of fault location (transformer vs. line faults, exact location for line faults) and reclosing features. A direct transfer trip from the 87T to the 87L allows fast clearing of transformer zone faults. However, another solution is to use the SEL-411L as a current differential relay for the combined line and transformer zones as shown in Figure 38. This is an economic alternative if neither reclosing nor multiterminal fault locating are necessary.

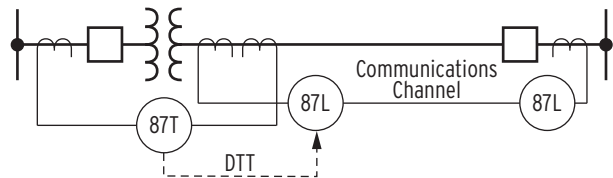

Figure 37 Preferred Application for Lines With Transformer

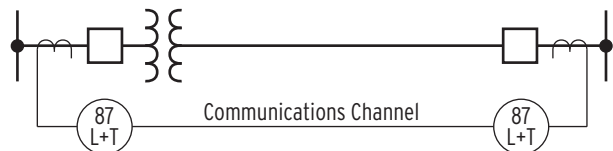
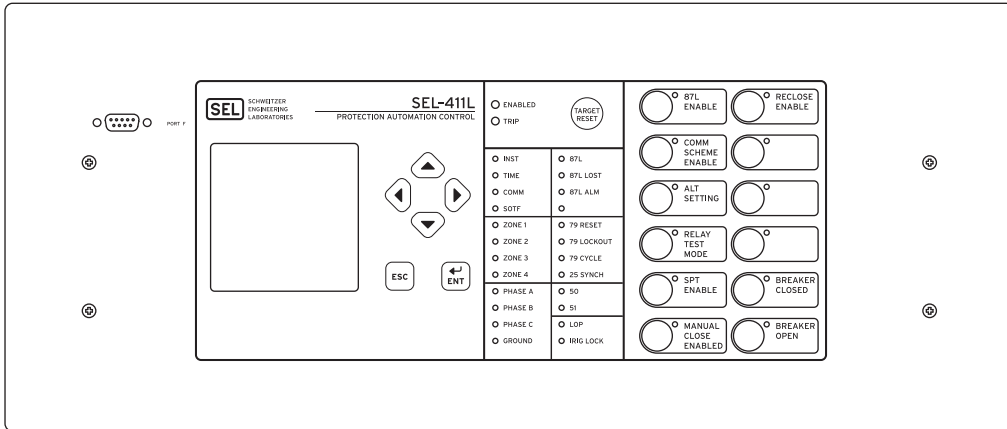

Figure 38 In-Line Transformer With Combined Line and Transformer Current Differential

Front- and Rear-Panel Diagrams



4U Front Panel, Panel-Mount Option

15036d

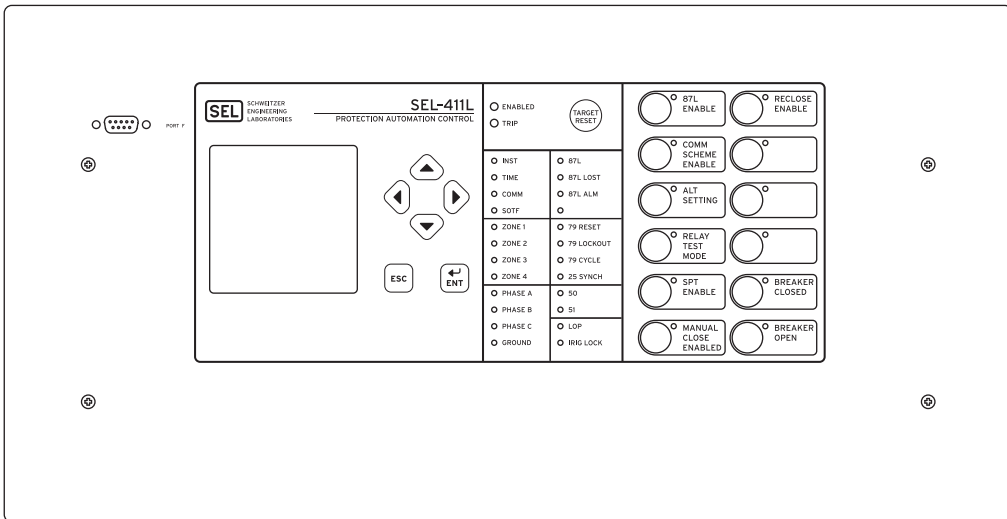

5U Front Panel, Panel-Mount Option

15037d

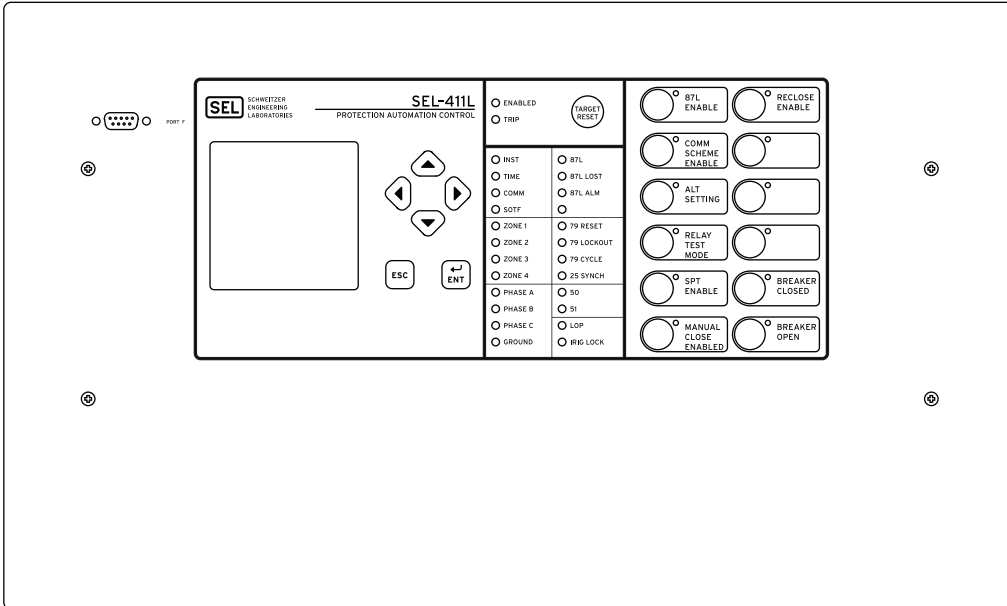

6U Front Panel, Panel-Mount Option

16294a

Figure 39 Typical SEL-411L Front-Panel Diagrams

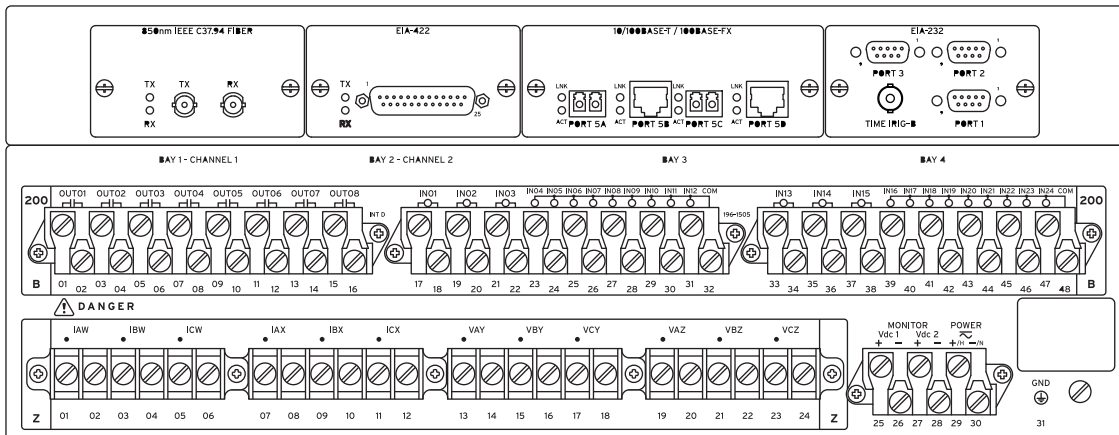

4U Rear Panel, Terminal Block, One INTD I/O Board Option

15205b

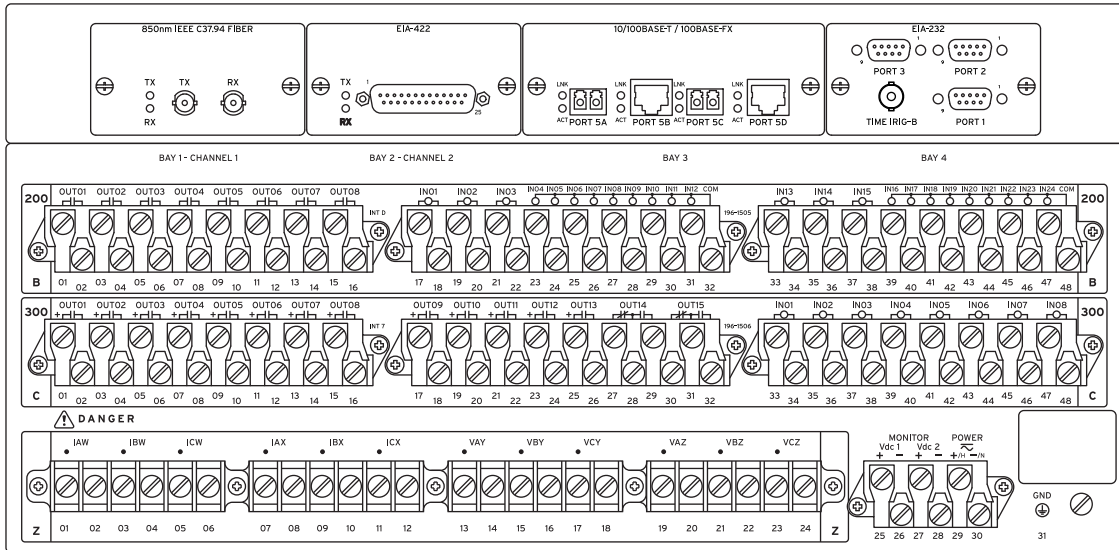

5U Rear Panel, Terminal Block, Two (INTD and INT7) I/O Board Option

15204b

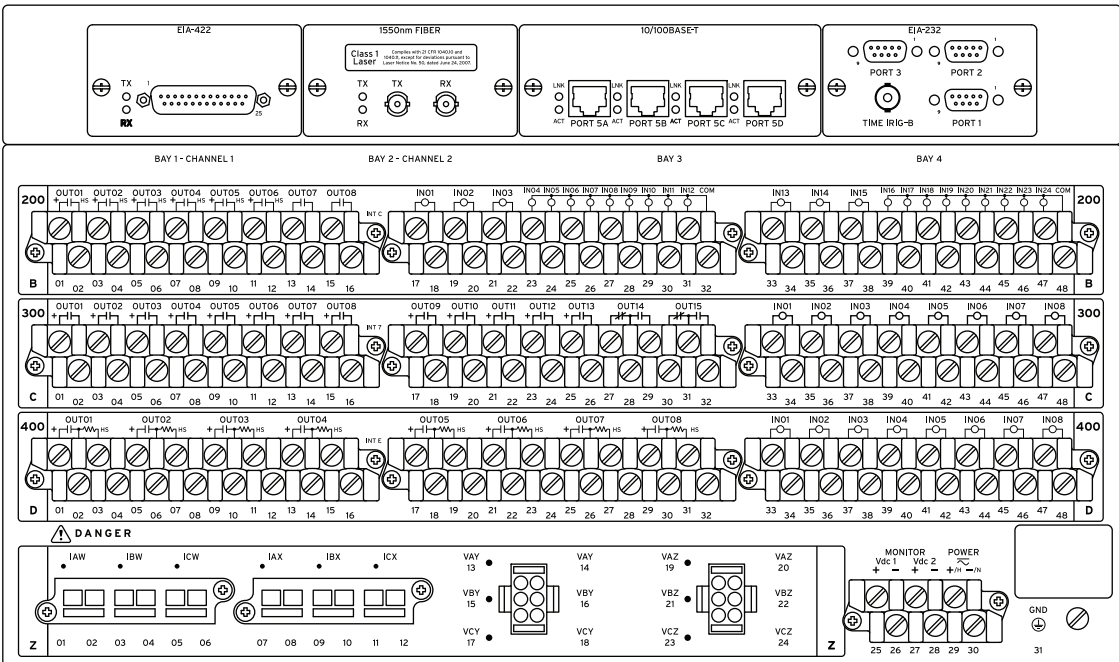

6U Rear Panel, Connectorized Terminal Block, Three (INTC, INT7 and INTE) I/O Board Option

16287a

Figure 40 Typical Rear-Panel Diagrams

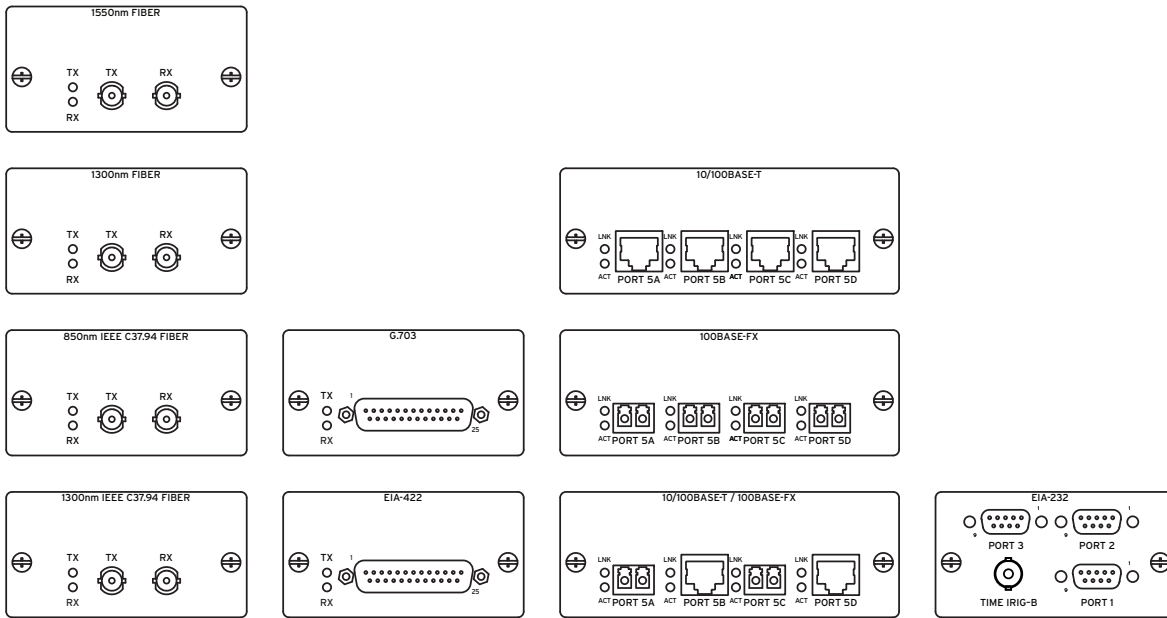

i5040d

Figure 41 SEL-411L 87L Communications, Ethernet, and Serial Board Options

Relay Dimensions

PANEL-MOUNT CHASSIS

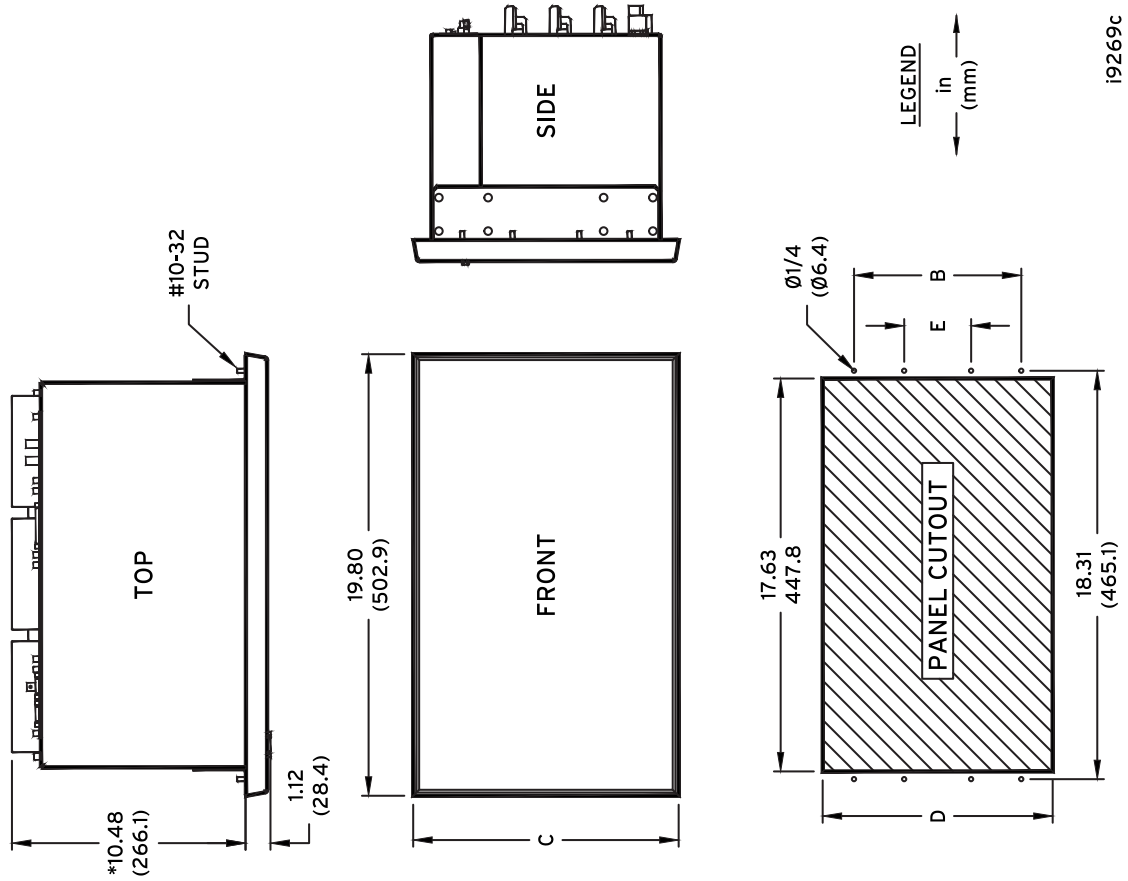

RACK-MOUNT CHASSIS

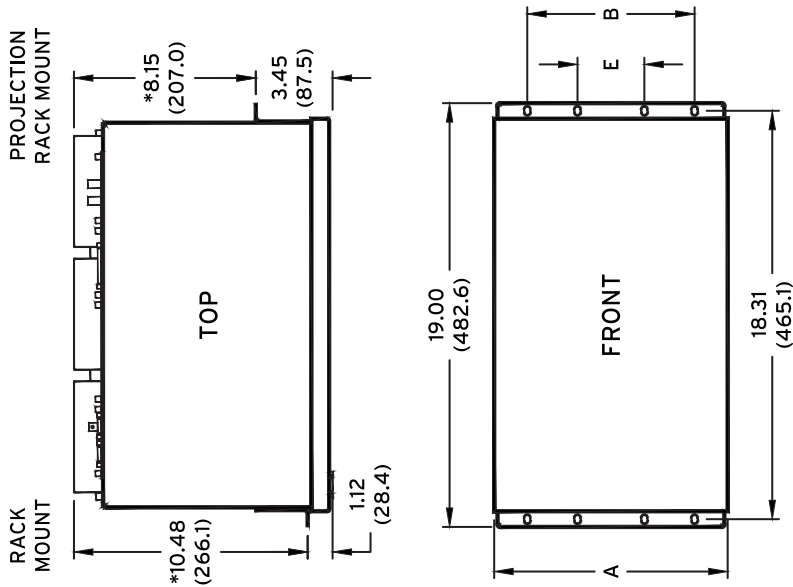

DIMENSION	ONE I/O BOARD (4U)	TWO I/O BOARD (5U)	THREE I/O BOARD (6U)
A	6.97 (177.0)	8.72 (221.5)	10.47 (265.9)
B	4.00 (101.6)	5.75 (146.0)	7.50 (190.5)
C	8.40 (213.4)	10.15 (257.8)	11.90 (302.3)
D	6.85 (174.0)	8.60 (218.4)	10.35 (262.9)
E	N/A	N/A	3.00 (76.2)

*ADD 0.30 (7.6) FOR CONNECTORIZED RELAYS

LEGEND
in (mm)

19269c

Specifications

Compliance

Designed and manufactured under an ISO 9001 certified quality management system

47 CFR 15B Class A

This equipment has been tested and found to comply with the limits for a Class A digital device, pursuant to part 15 of the FCC Rules. These limits are designed to provide reasonable protection against harmful interference when the equipment is operated in a commercial environment. This equipment generates, uses, and can radiate radio frequency energy and, if not installed and used in accordance with the instruction manual, may cause harmful interference in which case the user will be required to correct the interference at his own expense.

UL Listed to U.S. and Canadian safety standards (File E212775; NRGU, NRGU7)

CE Mark

General

AC Analog Inputs

Sampling Rate: 8 kHz

AC Current Inputs (Secondary Circuits)

Current Rating (With DC Offset at X/R = 10, 1.5 cycles)

1 A Nominal: 18.2 A

5 A Nominal: 91 A

Continuous Thermal Rating

1 A Nominal: 3 A
4 A (+55°C)

5 A Nominal: 15 A
20 A (+55°C)

Saturation Current (Linear) Rating

1 A Nominal: 20 A

5 A Nominal: 100 A

A/D Current Limit (Peak)

1 A Nominal: 49.5 A

5 A Nominal: 247.5 A

One-Second Thermal Rating

1 A Nominal: 100 A

5 A Nominal: 500 A

One-Cycle Thermal Rating (Peak)

1 A Nominal: 250 A

5 A Nominal: 1250 A

Burden Rating

1 A Nominal: ≤ 0.1 VA @ 1 A

5 A Nominal: ≤ 0.5 VA @ 5 A

AC Voltage Inputs

Rated Voltage Range: 0–300 V_{LN}

Ten-Second Thermal Rating: 600 Vac

Burden: < 0.1 VA @ 125 V

Frequency and Rotation

System Frequency: 50/60 Hz

Phase Rotation: ABC or ACB

Nominal Frequency Rating: 50 \pm 5 Hz
60 \pm 5 Hz

Frequency Tracking (Requires PTs): Tracks between 40.0–65.0 Hz
Below 40 Hz = 40 Hz
Above 65.0 Hz = 65 Hz

Maximum Slew Rate: 15 Hz per s

Power Supply

48–125 Vdc or 110–120 Vac

Rated Voltage: 48–125 Vdc, 110–120 Vac

Operational Voltage Range: 38–140 Vdc
85–140 Vac

Rated Frequency: 50/60 Hz

Operational Frequency Range: 30–120 Hz

Vdc Input Ripple: 15% per IEC 60255-26:2013

Interruption: 14 ms @ 48 Vdc, 160 ms @ 125 Vdc
per IEC 60255-26:2013

Burden: < 35 W, < 90 VA

125–250 Vdc or 120–240 Vac

Rated Voltage: 125–250 Vdc
110–240 Vac

Operational Voltage Range: 85–300 Vdc
85–264 Vac

Rated Frequency: 50/60 Hz

Operational Frequency Range: 30–120 Hz

Vdc Input Ripple: 15% per IEC 60255-26:2013

Interruption: 46 ms @ 125 Vdc, 250 ms @ 250 Vdc
per IEC 60255-26:2013

Burden: < 35 W, < 90 VA

Control Outputs

Note: IEEE C37.90-2005 and IEC 60255-27:2013

Update Rate: 1/8 cycle

Make (Short Duration Contact Current): 30 Adc
1,000 operations at 250 Vdc
2,000 operations at 125 Vdc

Limiting Making Capacity: 1000 W at 250 Vdc (L/R = 40 ms)

Mechanical Endurance: 10,000 operations

Standard

Rated Voltage: 48–250 Vdc
110–240 Vrms

Operational Voltage Range: 0–300 Vdc
0–264 Vrms

Operating Time: Pickup ≤ 6 ms (resistive load)
Dropout ≤ 6 ms (resistive load)

Short-Time Thermal Withstand: 50 A for 1 s

Continuous Contact Current: 6 A at 70°C
4 A at 85°C

Contact Protection: MOV protection across open contacts
264 Vrms continuous voltage
300 Vdc continuous voltage

Limiting Breaking Capacity/Electrical Endurance: 10,000 operations
10 operations in 4 seconds, followed by
2 minutes idle

Rated Voltage	Resistive Break	Inductive Break L/R = 40 ms (DC) PF = 0.4 (AC)
48 Vdc	0.63 Adc	0.63 Adc
125 Vdc	0.30 Adc	0.30 Adc
250 Vdc	0.20 Adc	0.20 Adc
110 Vrms	0.30 Arms	0.30 Arms
240 Vrms	0.20 Arms	0.20 Arms

Hybrid (High-Current Interrupting)

Rated Voltage:	48–250 Vdc
Operational Voltage Range:	0–300 Vdc
Operating Time:	Pickup ≤6 ms (resistive load) Dropout ≤6 ms (resistive load)
Short Time Thermal Withstand:	50 Adc for 1 s
Continuous Contact Current:	6 Adc at 70°C 4 Adc at 85°C
Contact Protection:	MOV protection across open contacts 300 Vdc continuous voltage
Limiting Breaking Capacity/Electrical Endurance:	10,000 operations 4 operations in 1 second, followed by 2 minutes idle

Rated Voltage	Resistive Break	Inductive Break
48 Vdc	10 Adc	10 Adc (L/R = 40 ms)
125 Vdc	10 Adc	10 Adc (L/R = 40 ms)
250 Vdc	10 Adc	10 Adc (L/R = 20 ms)

Fast Hybrid (High-Speed High-Current Interrupting)

Rated Voltage:	48–250 Vdc
Operational Voltage Range:	0–300 Vdc
Operating Time:	Pickup ≤10 μs (resistive load) Dropout ≤8 ms (resistive load)
Short Time Thermal Withstand:	50 Adc for 1 s
Continuous Contact Current:	6 Adc at 70°C 4 Adc at 85°C
Contact Protection:	MOV protection across open contacts 300 Vdc continuous voltage
Limiting Breaking Capacity/Electrical Endurance:	10,000 operations 4 operations in 1 second, followed by 2 minutes idle

Rated Voltage	Resistive Break	Inductive Break
48 Vdc	10 Adc	10 Adc (L/R = 40 ms)
125 Vdc	10 Adc	10 Adc (L/R = 40 ms)
250 Vdc	10 Adc	10 Adc (L/R = 20 ms)

Note: Do not use hybrid control outputs to switch ac control signals. These outputs are polarity-dependent.

Control Inputs

Optoisolated (Use With AC or DC Signals)

Main Board:	No I/O
INT2, INT7, and INTE Interface Boards:	8 inputs with no shared terminals
INTC and INTD Interface Board:	6 inputs with no shared terminals 18 inputs with shared terminals (2 groups of 9 inputs with each group sharing one terminal)
Voltage Options:	48, 110, 125, 220, 250 V
Current Draw:	<5 mA at nominal voltage <8 mA for 110 V option
Sampling Rate:	2 kHz

DC Thresholds

48 Vdc:	Pickup 38.4–60.0 Vdc; Dropout <28.8 Vdc
110 Vdc:	Pickup 88.0–132.0 Vdc; Dropout <66.0 Vdc
125 Vdc:	Pickup 105–150.0 Vdc; Dropout <75 Vdc
220 Vdc:	Pickup 176–264.0 Vdc; Dropout <132 Vdc
250 Vdc:	Pickup 200–300.0 Vdc; Dropout <150 Vdc

AC Thresholds (Ratings met only when recommended control input settings are used.)

48 Vac:	Pickup 32.8–60.0 Vac rms; Dropout <20.3 Vac rms
110 Vac:	Pickup 75.1–132.0 Vac rms; Dropout <46.6 Vac rms
125 Vac:	Pickup 89.6–150.0 Vac rms; Dropout <53.0 Vac rms
220 Vac:	Pickup 150.3–264.0 Vac rms; Dropout <93.2 Vac rms
250 Vac:	Pickup 170.6–264.0 Vac rms; Dropout <106 Vac rms

Communications Ports

EIA-232:	1 Front and 3 Rear
Serial Data Speed:	300–57600 bps

Communications Card Slot for Optional Ethernet Card

Ordering Options:	100BASE-FX fiber-optic Ethernet
Mode:	Multi
Wavelength (nm):	1300
Source:	LED
Connector Type:	LC
TX Pwr. (Avg dBm):	–19 to –14
RX Sens. (dBm):	–32
Sys. Gain (dB):	13

Differential Communications Ports

Fiber Optics–ST Connector

1550 nm Single-Mode	
Tx Power:	–18 dBm
Rx Min. Sensitivity:	–58 dBm
Rx Max. Sensitivity:	0 dBm
System Gain:	40 dB
Distance Limitations:	120 km

1300 nm Multimode or Single-Mode

Tx Power:	-18 dBm
Rx Min. Sensitivity:	-58 dBm
Rx Max. Sensitivity:	0 dBm
System Gain:	40 dB
Distance Limitations:	x km

where: x = 30 for multimode
x = 80 for single mode

1300 Single-Mode (C37.94 Modulated):

Tx Power:	-24 dBm
Rx Min. Sensitivity:	-37.8 dBm
Rx Max. Sensitivity:	0 dBm
System Gain:	13.8 dB
Distance Limitations:	15 km

850 nm Multimode, C37.94

Tx Power:	50 μ m: -23 dBm; 62.5 μ m: -19 dBm
Rx Min. Sensitivity:	50 μ m: -32 dBm; 62.5 μ m: -32 dBm
Rx Max. Sensitivity:	50 μ m: -11 dBm; 62.5 μ m: -11 dBm
System Gain:	50 μ m: 9 dB; 62.5 μ m: 13 dB
Distance Limitations:	2 km

Electrical

EIA-422:	64 kbps synchronous
CCITT G.703:	64 kbps synchronous, codirectional

Time Inputs

IRIG-B Input-Serial Port 1

Input:	Demodulated IRIG-B
Rated Voltage:	5 Vdc
Operational Voltage Range:	0-8 Vdc
Logic High Threshold:	≥ 2.8 Vdc
Logic Low Threshold:	≤ 0.8 Vdc
Input Impedance:	2.5 k Ω

IRIG-B Input-BNC Connector

Input:	Demodulated IRIG-B
Rated Voltage:	5 Vdc
Operational Voltage Range:	0-8 Vdc
Logic High Threshold:	≥ 2.8 Vdc
Logic Low Threshold:	≤ 0.8 Vdc
Input Impedance:	> 1 k Ω
Rated Insulation Voltage:	150 Vdc

PTP-Ethernet Port 5A, 5B

Input:	IEEE 1588 PTPv2
Profiles:	Default, C37.238-2011 (Power Profile)
Synchronization Accuracy:	± 100 ns @ 1-second synchronization intervals when communicating directly with master clock

Operating Temperature

-40° to +85°C (-40° to +185°F)

Note: LCD contrast impaired for temperatures below -20° and above +70°C

Humidity

5% to 95% without condensation

Overvoltage Category

Category II

Insulation Class

I

Pollution Degree

2

Weight (Maximum)

4U Rack Unit:	10.3 kg (22.8 lb)
5U Rack Unit:	12.0 kg (26.4 lb)
6U Rack Unit:	13.4 kg (29.6 lb)

Terminal Connections

Rear Screw-Terminal Tightening Torque, #8 Ring Lug

Minimum:	1.0 Nm (9 in-lb)
Maximum:	2.0 Nm (18 in-lb)

User terminals and stranded copper wire should have a minimum temperature rating of 105°C. Ring terminals are recommended.

Wire Sizes and Insulation

Wire sizes for grounding (earthing), current, voltage, and contact connections are dictated by the terminal blocks and expected load currents. You can use the following table as a guide in selecting wire sizes. The grounding conductor should be as short as possible and sized equal to or greater than any other conductor connected to the device, unless otherwise required by local or national wiring regulations.

Connection Type	Min. Wire Size	Max. Wire Size
Grounding (Earthing) Connection	14 AWG (2.5 mm ²)	N/A
Current Connection	16 AWG (1.5 mm ²)	10 AWG (5.3 mm ²)
Potential (Voltage) Connection	18 AWG (0.8 mm ²)	14 AWG (2.5 mm ²)
Contact I/O	18 AWG (0.8 mm ²)	10 AWG (5.3 mm ²)
Other Connection	18 AWG (0.8 mm ²)	10 AWG (5.3 mm ²)

Type Tests

Electromagnetic Compatibility (EMC)

Emissions: IEC 60255-26:2013, Section 7.1 Class A

Electromagnetic Compatibility Immunity

Conducted RFI Immunity: IEC 60255-26:2013, Section 7.2.8
10 Vrms

Radiated RFI Immunity: IEC 60255-26:2013, Section 7.2.4
10 V/m (unmodulated)
IEEE C37.90.2-2004
20 V/m (unmodulated)

Electrostatic Discharge Immunity: IEC 60255-26:2013, Section 7.2.3
IEEE C37.90.3-2001
2, 4, 6, and 8 kV contact discharge
2, 4, 8, and 15 kV air discharge

Electrical Fast Transient Burst Immunity: IEC 60255-26:2013, Section 7.2.5
Class A:
4 kV, 5 kHz
2 kV, 5 kHz on communications ports

Power Frequency Immunity: IEC 60255-26:2013, Section 7.2.9

Power Frequency Magnetic Field Immunity: IEC 60255-26, Section 7.2.10
Level 5

1000 A/m for 3 s
100 A/m for 60 s

Note:

50G1P ≥ 0.05 (ESS = N, 1, 2)
50G1P ≥ 0.1 (ESS = 3, 4)

Pulse Magnetic Field Immunity:	IEC 61000-4-9:2001 Level 5 1000 A/m
Damped Oscillatory Magnetic Field:	IEC 61000-4-10:2001 Level 5 100 A/m
Power Supply Immunity:	IEC 60255-26:2013, Section 7.2.11, 7.2.12, 7.2.13 IEC 60255-27:2013, Section 5.1.3, 10.6.6
Surge Immunity:	IEC 60255-26, Section 7.2.7 Zone A Line-to-line: 0.5, 1.0, 2.0 kV Line-to-earth: 0.5, 1.0, 2.0, 4.0 kV Comm ports (Ethernet): 0.5, 1.0, 2.0, 4.0 kV Zone B Comm ports (except Ethernet): 0.5, 1.0, 2.0 kV
Note: Cables connected to EIA-422, G.703, and IRIG-B communications ports shall be shorter than 10 m for Zone A compliance.	
Note: Cables connected to EIA-232 communications ports shall be shorter than 10 m for Zone A/B compliance.	
Surge Withstand Capability Immunity:	IEC 60255-26:2013, Section 7.2.6 2.5 kV peak common mode 1.0 kV peak differential mode IEEE C37.90.1-2012 2.5 kV oscillatory 4.0 kV fast transient

Environmental

Cold, Operational:	IEC 60255-27:2013, Section 10.6.1.2 Test Ad: 16 hours at -40°C
Cold, Storage:	IEC 60255-27:2013, Section 10.6.1.4
Dry Heat, Operational:	IEC 60255-27:2013, Section 10.6.1.1 Test Bd: 16 hours at +85°C
Dry Heat, Storage:	IEC 60255-27:2013, Section 10.6.1.3
Damp Heat, Cyclic:	IEC 60255-27:2013, Section 10.6.1.6 Test Db: +25° to +55°C, 6 cycles (12 + 12-hour cycle), 95% RH
Damp Heat, Steady State:	IEC 60255-27:2013, Section 10.6.1.5 Severity: 93% RH, +40C, 10 days
Object Penetration:	IEC 60255-27:2013, Section 10.6.2.6 Protection Class: IP30
Vibration Resistance:	IEC 60255-27:2013, Section 10.6.2.1 Class 2 Endurance, Class 2 Response
Shock Resistance:	IEC 60255-27:2013, Section 10.6.2.2 and 10.6.2.3 Class 1 Shock Withstand, Class 1 Bump Withstand, Class 2 Shock Response
Seismic:	IEC 60255-27:2013, Section 10.6.2.4 Class 2 Quake Response

Safety

Dielectric Strength:	IEC 60255-27:2013, Section 10.6.4.3 IEEE C37.90-2005, Section 8 2.2 kVdc: IRIG-B 2.5 kVrms: analog inputs, digital inputs, and digital outputs 3.6 kVdc: power supply and battery monitor
Impulse:	IEC 60255-27:2013, Section 10.6.4.2 IEEE C37.90-2005, Impulse Section 2.5 kV: IRIG-B 5 kV: analog inputs, digital inputs, digital outputs, power supply, and battery monitor
Insulation Resistance:	IEC 60255-27:2013, Section 10.6.4.4
Flammability of Insulating Materials:	IEC 60255-27:2013, Section 7.6

Max Temperature of Parts and Materials, Normal Use:	IEC 60255-27:2013, Section 7.3
Protective Bonding Continuity:	IEC 60255-27:2013, Section 10.6.4.5.2
Laser Safety:	21 CFR 1040.10 IEC 60825-1:2014 Class 1

Reporting Functions

Traveling-Wave Fault Location

Application:	Two terminal lines with high-accuracy time sources
Type:	Type D (double-ended)
Sampling Rate:	1.5625 MHz
Accuracy:	±25 meters for a step change in current applied simultaneously to both relays
Output Format:	Binary COMTRADE

High-Resolution Data

Rate:	8000 samples/second 4000 samples/second 2000 samples/second 1000 samples/second
Output Format:	Binary COMTRADE
Note: Per IEEE Std C37.111-1999 and C37.111-2013, Common Format for Transient Data Exchange (COMTRADE) for Power Systems.	

Event Reports

Resolution:	8- or 4-samples/cycle
-------------	-----------------------

Event Summary

Storage:	100 summaries
----------	---------------

Breaker History

Storage:	128 histories
----------	---------------

Sequential Events Recorder

Storage:	1000 entries
Trigger Elements:	250 relay elements
Resolution:	0.5 ms for contact inputs 1/8 cycle for all elements

Processing Specifications

AC Voltage and Current Inputs

8000 samples per second, 3 dB low-pass analog filter cut-off frequency of 3000 Hz

Digital Filtering

Full-cycle cosine and half-cycle Fourier filters after low-pass analog and digital filtering

Protection and Control Processing

8 times per power system cycle

Synchrophasors

Maximum data rate in messages per second	
IEEE C37.118 Protocol:	60 (nominal 60 Hz system) 50 (nominal 50 Hz system)
SEL Fast Message Protocol:	20 (nominal 60 Hz system) 10 (nominal 50 Hz system)

Control Points

32 remote bits
32 local control bits
32 latch bits in protection logic
32 latch bits in automation logic

Relay Element Pickup Ranges and Accuracies

Line Current Differential (87L) Elements

87L Enable Levels

Unrestraint Differential
Element Setting Range: OFF, 3.0 to 15 per unit, 0.1 pu steps

Phase Setting Range
(Normal): OFF, 0.10 to 2 per unit, 0.01 pu steps

Phase Setting Range
(Secure): OFF, 0.10 to 2 per unit, 0.01 pu steps

Negative-Sequence

Setting Range (Normal): OFF, 0.10 to 2.00 per unit, 0.01 pu steps

Setting Range (Secure): OFF, 0.10 to 2.00 per unit, 0.01 pu steps

Zero-Sequence

Setting Range (Normal): OFF, 0.10 to 2.00 per unit, 0.01 pu steps

Setting Range (Secure): OFF, 0.10 to 2.00 per unit, 0.01 pu steps

Accuracy: $\pm 3\% \pm 0.01 I_{NOM}$

Restraint Characteristics

Outer Radius (Phase, Negative-Sequence, Zero-Sequence)

Radius Range (Normal): 1.2 to 8 in steps of 0.01 (unitless)

Radius Range (Secure): 1.2 to 8 in steps of 0.01 (unitless)

Angle Range (Normal): $90-270^\circ$ in steps of 1°

Angle Range (Secure): $90-270^\circ$ in steps of 1°

Accuracy: $\pm 5\%$ of radius setting
 $\pm 3^\circ$ of angle setting

Line-Charging Current Compensation

Positive-Sequence Line
Susceptance Setting Range: 0.00 to 250 mS, 0.01 mS steps

Zero-Sequence Line
Susceptance Setting Range: 0.00 to 100 mS, 0.01 mS steps

In-Line Transformer

MVA Setting Range: 1 to 5,000, 1 MVA steps

Vector Group
Compensation: 360° , 30° steps

Line-to-Line Setting Range: 1.00 to 1,000 kV, 0.01 kV steps

Harmonic Restraint: 2nd, 4th Setting Range: OFF, 5 to 100%,
1% steps

Harmonic Blocking: 2nd, 4th and 5th Setting Range: OFF,
5 to 100%, 1% steps

Mho Phase-Distance Elements

Zones 1-5 Impedance Reach

Setting Range

5 A Model: OFF, 0.05 to 64 Ω secondary,
0.01 Ω steps

1 A Model: OFF, 0.25 to 320 Ω secondary,
0.01 Ω steps

Sensitivity

5 A Model: 0.5 A_{p-p} secondary

1 A Model: 0.1 A_{p-p} secondary
(Minimum sensitivity is controlled by the pickup of the supervising phase-to-phase overcurrent elements for each zone.)

Accuracy (Steady State): $\pm 3\%$ of setting at line angle for SIR < 30
(source-to-line impedance ratio) < 30
 $\pm 5\%$ of setting at line angle for $30 \leq SIR \leq 60$

Zone 1 Transient Overreach: $< 5\%$ of setting plus steady-state accuracy

Relay Version -1 Maximum
Operating Time: 0.8 cycle at 100% of reach and SIR = 1

Relay Version -0 Maximum
Operating Time: 1.5 cycle at 100% of reach and SIR = 1

Quadrilateral Phase-Distance Elements

Zones 1-5 Impedance Reach

Quadrilateral Reactance Reach

5 A Model: OFF, 0.05 to 64 Ω secondary, 0.01 Ω steps

1 A Model: OFF, 0.25 to 320 Ω secondary,
0.01 Ω steps

Quadrilateral Resistance Reach

Zones 1, 2, and 3

5 A Model: OFF, 0.05 to 50 Ω secondary, 0.01 Ω steps

Zones 1, 2, and 3

1 A Model: OFF, 0.25 to 250 Ω secondary, 0.01 Ω steps

Zones 4 and 5

5 A Model: OFF, 0.05 to 150 Ω secondary, 0.01 Ω steps

Zones 4 and 5

1 A Model: OFF, 0.25 to 750 Ω secondary, 0.01 Ω steps

Sensitivity

5 A Model: 0.5 A secondary

1 A Model: 0.1 A secondary

Accuracy (Steady State): $\pm 3\%$ of setting at line angle for SIR < 30
 $\pm 5\%$ of setting at line angle for $30 \leq SIR \leq 60$

Transient Overreach: $< 5\%$ of setting plus steady-state accuracy

Relay Version -1 Maximum
Operating Time: 1.0 cycle at 70% of reach and SIR = 1

Relay Version -0 Maximum
Operating Time: 1.5 cycle at 70% of reach and SIR = 1

Mho Ground-Distance Elements

Zones 1-5 Impedance Reach

Mho Element Reach

5 A Model: OFF, 0.05 to 64 Ω secondary, 0.01 Ω steps

1 A Model: OFF, 0.25 to 320 Ω secondary, 0.01 Ω steps

Sensitivity

5 A Model: 0.5 A secondary

1 A Model: 0.1 A secondary
(Minimum sensitivity is controlled by the pickup of the supervising phase and residual overcurrent elements for each zone.)

Accuracy (Steady State): $\pm 3\%$ of setting at line angle for SIR < 30
 $\pm 5\%$ of setting at line angle for $30 \leq SIR \leq 60$

Zone 1 Transient Overreach: $< 5\%$ of setting plus steady-state accuracy

Relay Version -1 Maximum
Operating Time: 0.8 cycle at 100% of reach and SIR = 1

Relay Version -0 Maximum
Operating Time: 1.5 cycle at 100% of reach and SIR = 1

Quadrilateral Ground-Distance Elements

Zones 1-5 Impedance Reach

Quadrilateral Reactance Reach

5 A Model: OFF, 0.05 to 64 Ω secondary, 0.01 Ω steps

1 A Model: OFF, 0.25 to 320 Ω secondary, 0.01 Ω steps

Quadrilateral Resistance Reach	
Zones 1, 2, and 3 5 A Model:	OFF, 0.05 to 50 Ω secondary, 0.01 Ω steps
Zones 1, 2, and 3 1 A Model:	OFF, 0.25 to 250 Ω secondary, 0.01 Ω steps
Zones 4 and 5 5 A Model:	OFF, 0.05 to 150 Ω secondary, 0.01 Ω steps
Zones 4 and 5 1 A Model:	OFF, 0.25 to 750 Ω secondary, 0.01 Ω steps
Sensitivity	
5 A Model:	0.5 A secondary
1 A Model:	0.1 A secondary (Minimum sensitivity is controlled by the pickup of the supervising phase and residual overcurrent elements for each zone.)
Accuracy (Steady State):	$\pm 3\%$ of setting at line angle for $SIR < 30$ $\pm 5\%$ of setting at line angle for $30 \leq SIR \leq 60$
Transient Overreach:	$< 5\%$ of setting plus steady-state accuracy
Relay Version -1 Maximum Operating Time:	1.0 cycle at 70% of reach and $SIR = 1$
Relay Version -0 Maximum Operating Time:	1.5 cycle at 70% of reach and $SIR = 1$

Instantaneous/Definite-Time Overcurrent Elements

Phase, Residual Ground, and Negative-Sequence	
Pickup Range	
5 A Model:	OFF, 0.25–100.00 A secondary, 0.01 A steps
1 A Model:	OFF, 0.05–20.00 A secondary, 0.01 A steps
Accuracy (Steady State)	
5 A Model:	± 0.05 A plus $\pm 3\%$ of setting
1 A Model:	± 0.01 A plus $\pm 3\%$ of setting
Transient Overreach:	$< 5\%$ of pickup
Time Delay:	0.00–16000.00 cycles, 0.125 cycle steps
Timer Accuracy:	± 0.125 cycle plus $\pm 0.1\%$ of setting
Maximum Operating Time:	1.5 cycles

High-Speed Directional Overcurrent Elements

Ground and Phase	
Pickup Range	
5 A Model:	OFF, 0.25–100 A secondary, 0.01 A steps
1 A Model:	OFF, 0.05–20 A secondary, 0.01 A steps
Transient Overreach:	5% of pickup
Maximum Operating Time:	0.75 cycles

Time-Overcurrent Elements

Pickup Range	
5 A Model:	0.25–16.00 A secondary, 0.01 A steps
1 A Model:	0.05–3.20 A secondary, 0.01 A steps
Accuracy (Steady State)	
5 A Model:	± 0.05 A plus $\pm 3\%$ of setting
1 A Model:	± 0.01 A plus $\pm 3\%$ of setting
Time Dial Range	
U.S.:	0.50–15.00, 0.01 steps
IEC:	0.05–1.00, 0.01 steps

Curve Timing Accuracy:	± 1.50 cycles plus $\pm 4\%$ of curve time (for current between 2 and 30 multiples of pickup)
Reset:	1 power cycle or Electromechanical Reset Emulation time

Ground-Directional Elements

Neg.-Seq. Directional Impedance Threshold (Z2F, Z2R)	
5 A Model:	–64 to 64 Ω
1 A Model:	–320 to 320 Ω
Zero-Seq. Directional Impedance Threshold (Z0F, Z0R)	
5 A Model:	–64 to 64 Ω
1 A Model:	–320 to 320 Ω
Supervisory Overcurrent Pickup 50FP, 50RP	
5 A Model:	0.25 to 5.00 A 3I0 secondary 0.25 to 5.00 A 3I2 secondary
1 A Model:	0.05 to 1.00 A 3I0 secondary 0.05 to 1.00 A 3I2 secondary

Directional Power Elements

Pickup Range	
5 A Model:	–20000.00 to 20000 VA, 0.01 VA steps
1 A Model:	–4000.00 to 4000 VA, 0.01 VA steps
Accuracy (Steady State):	± 5 VA plus $\pm 3\%$ of setting at nominal frequency and voltage
Time-Delay:	0.00–16000.00 cycles, 0.25 cycle steps
Timer Accuracy:	± 0.25 cycle plus $\pm 0.1\%$ of setting

Under- and Overvoltage Elements

Pickup Ranges:	Phase elements: 1–200 V secondary, 1 V steps
Phase-to-Phase Elements:	1.0–300.0 V secondary, 0.1 V steps
Accuracy (Steady State):	± 1 V plus $\pm 5\%$ of setting
Transient Overreach:	$< 5\%$ of pickup

Under- and Overfrequency Elements

Pickup Range:	40.01–69.99 Hz, 0.01 Hz steps
Accuracy, Steady State Plus Transient:	± 0.005 Hz for frequencies between 40.00 and 70.00 Hz
Maximum Pickup/Dropout Time:	3.0 cycles
Time-Delay Range:	0.04–400.0 s, 0.01 s increments
Time-Delay Accuracy:	$\pm 0.1\% \pm 0.0042$ s
Pickup Range, Undervoltage Blocking:	20.00–200.00 V_{LN} (Wye)
Pickup Accuracy, Undervoltage Blocking:	$\pm 2\% \pm 2$ V

Optional RTD Elements (Models Compatible With SEL-2600A RTD Module)

12 RTD Inputs via SEL-2600 RTD Module and SEL-2800 Fiber-Optic Transceiver	
Monitor Ambient or Other Temperatures	
PT 100, NI 100, NI 120, and CU 10 RTD-Types Supported, Field Selectable	
As long as 500 m Fiber-Optic Cable to SEL-2600 RTD Module	

Breaker-Failure Instantaneous Overcurrent

Setting Range	
5 A Model:	0.50–50.0 A, 0.01 A steps
1 A Model:	0.10–10.0 A, 0.01 A steps

Accuracy	
5 A Model:	± 0.05 A plus $\pm 3\%$ of setting
1 A Model:	± 0.01 A plus $\pm 3\%$ of setting
Transient Overreach:	$< 5\%$ of setting
Maximum Pickup Time:	1.5 cycles
Maximum Reset Time:	1 cycle
Timers Setting Range:	0–6000 cycles, 0.125 cycle steps (All but BFIDOn, BFISPn) 0–1000 cycles, 0.125 cycle steps (BFIDOn, BFISPn)
Time Delay Accuracy:	0.125 cycle plus $\pm 0.1\%$ of setting

Synchronism-Check Elements

Slip Frequency Pickup Range:	0.005–0.500 Hz, 0.001 Hz steps
Slip Frequency Pickup Accuracy:	± 0.0025 Hz plus $\pm 2\%$ of setting
Close Angle Range:	3–80°, 1° steps
Close Angle Accuracy:	$\pm 3^\circ$

Load-Encroachment Detection

Setting Range	
5 A Model:	0.05–64 Ω secondary, 0.01 Ω steps
1 A Model:	0.25–320 Ω secondary, 0.01 Ω steps
Forward Load Angle:	–90° to +90°
Reverse Load Angle:	+90° to +270°
Accuracy	
Impedance Measurement:	$\pm 3\%$
Angle Measurement:	$\pm 2^\circ$

Out-of-Step Elements

Blinders (R1) Parallel to the Line Angle	
5 A Model:	0.05 to 140 Ω secondary –0.05 to –140 Ω secondary
1 A Model:	0.25 to 700 Ω secondary –0.25 to –700 Ω secondary
Blinders (X1) Perpendicular to the Line Angle	
5 A Model:	0.05 to 96 Ω secondary –0.05 to –96 Ω secondary
1 A Model:	0.25 to 480 Ω secondary –0.25 to –480 Ω secondary
Accuracy (Steady State)	
5 A Model:	$\pm 5\%$ of setting plus ± 0.01 A for SIR (source to line impedance ratio) < 30 $\pm 10\%$ of setting plus ± 0.01 A for $30 \leq \text{SIR} \leq 60$
1 A Model:	$\pm 5\%$ of setting plus ± 0.05 A for SIR (source to line impedance ratio) < 30 $\pm 10\%$ of setting plus ± 0.05 A for $30 \leq \text{SIR} \leq 60$
Transient Overreach:	$< 5\%$ of setting <i>plus</i> steady-state accuracy

Positive-Sequence Overcurrent Supervision

Setting Range	
5 A Model:	1.0–100.0 A, 0.01 A steps
1 A Model:	0.2–20.0 A, 0.01 A steps

Accuracy	
5 A Model:	$\pm 3\%$ of setting plus ± 0.05 A
1 A Model:	$\pm 3\%$ of setting plus ± 0.01 A
Transient Overreach:	$< 5\%$ of setting

Bay Control

Breakers:	2 (control), 3rd indication
Disconnects (Isolators):	10 (maximum)
Timers Setting Range:	1–99999 cycles, 1-cycle steps
Time-Delay Accuracy:	$\pm 0.1\%$ of setting, ± 0.125 cycle

Timer Specifications

Breaker Failure:	0–6000 cycles, 0.125 cycle steps (All but BFIDOn, BFISPn) 0–1000 cycles, 0.125 cycle steps (BFIDOn, BFISPn)
Communications-Assisted Tripping Schemes:	0.000–16000 cycles, 0.125 cycle steps
Out-of-Step Timers	
OSBD, OSTD:	0.500–8000 cycles, 0.125 cycle steps
UBD:	0.500–120 cycles, 0.125 cycle steps
Pole-Open Timer:	0.000–60 cycles, 0.125 cycle steps
Recloser:	1–99999 cycles, 1 cycle steps
Switch-Onto-Fault	
CLOEND, 52AEND:	OFF, 0.000–16000 cycles, 0.125 cycle steps
SOTFD:	0.50–16000 cycles, 0.125 cycle steps
Synchronism-Check Timers	
TCLSBK1, TCLSBK2:	1.00–30.00 cycles, 0.25 cycle steps
Zone Time Delay:	0.000–16000 cycles, 0.125 cycle steps

Station DC Battery System Monitor Specifications

Rated Voltage:	15–300 Vdc
Operational Voltage Range:	0–350 Vdc
Sampling Rate:	DC1: 2 kHz DC2: 1 kHz
Processing Rate:	1/8 cycle
Operating Time:	< 1.5 cycles (all elements except ac ripple) < 1.5 seconds (ac ripple element)
Setting Range	
DC Settings:	1 Vdc steps (OFF, 15–300 Vdc)
AC Ripple Setting:	1 Vac steps (1–300 Vac)
Pickup Accuracy:	$\pm 3\% \pm 2$ Vdc (all elements except ac ripple) $\pm 10\% \pm 2$ Vac (ac ripple element)

Metering Accuracy

All metering accuracy is at 20°C, and nominal frequency unless otherwise noted.

Currents

Phase Current Magnitude	
5 A Model:	$\pm 0.2\%$ plus ± 4 mA (2.5–15 A s)
1 A Model:	$\pm 0.2\%$ plus ± 0.8 mA (0.5–3 A s)
Phase Current Angle	
All Models:	$\pm 0.2^\circ$ in the current range $0.5 \cdot I_{\text{NOM}}$ to $3.0 \cdot I_{\text{NOM}}$

Sequence Currents Magnitude

5 A Model: $\pm 0.3\%$ plus ± 4 mA (2.5–15 A s)

1 A Model: $\pm 0.3\%$ plus ± 0.8 mA (0.5–3 A s)

Sequence Current Angle

All Models: $\pm 0.3^\circ$ in the current range $0.5 \cdot I_{\text{NOM}}$ to $3.0 \cdot I_{\text{NOM}}$

Voltages

Phase and Phase-to-Phase Voltage Magnitude: $\pm 0.1\%$ (33.5–200 $V_{\text{L-N}}$)

Phase and Phase-to-Phase Angle: $\pm 0.5^\circ$ (33.5–200 $V_{\text{L-N}}$)

Sequence Voltage Magnitude: $\pm 0.15\%$ (33.5–200 $V_{\text{L-N}}$)

Sequence Voltage Angle: $\pm 0.5^\circ$ (33.5–200 $V_{\text{L-N}}$)

Frequency (Input 40–65 Hz)

Accuracy: ± 0.01 Hz

Power and Energy

Real Power, P (MW), Three Phase

At $0.1 \cdot I_{\text{NOM}}$

Power Factor Unity: $\pm 0.4\%$

Power Factor 0.5 Lag, 0.5 Lead: $\pm 0.7\%$

At $1.0 \cdot I_{\text{NOM}}$

Power Factor Unity: $\pm 0.4\%$

Power Factor 0.5 Lag, 0.5 Lead: $\pm 0.4\%$

Reactive Power, Q (MVAR), Three Phase

At $0.1 \cdot I_{\text{NOM}}$

Power Factor 0.5 Lag, 0.5 Lead: $\pm 0.5\%$

At $1.0 \cdot I_{\text{NOM}}$

Power Factor 0.5 Lag, 0.5 Lead: $\pm 0.4\%$

Energy (MWh), Three Phase

At $0.1 \cdot I_{\text{NOM}}$

Power Factor Unity: $\pm 0.5\%$

Power Factor 0.5 Lag, 0.5 Lead: $\pm 0.7\%$

At $1.0 \cdot I_{\text{NOM}}$

Power Factor Unity: $\pm 0.4\%$

Power Factor 0.5 Lag, 0.5 Lead: $\pm 0.4\%$

Synchrophasors

TVE (Total Vector Error): $\leq 1\%$

Frequency Range: ± 5 Hz of nominal (50 or 60 Hz)

Voltage Range: 30 V–150 V

Current Range: $(0.1\text{--}2) \cdot I_{\text{NOM}}$ ($I_{\text{NOM}} = 1$ A or 5 A)

Phase Angle Range: -179.99° to 180°

Protocol: IEEE C37.118-2005 or SEL Fast Message

Notes

© 2011-2018 by Schweitzer Engineering Laboratories, Inc. All rights reserved.

All brand or product names appearing in this document are the trademark or registered trademark of their respective holders. No SEL trademarks may be used without written permission. SEL products appearing in this document may be covered by U.S. and Foreign patents.

Schweitzer Engineering Laboratories, Inc. reserves all rights and benefits afforded under federal and international copyright and patent laws in its products, including without limitation software, firmware, and documentation.

The information in this document is provided for informational use only and is subject to change without notice. Schweitzer Engineering Laboratories, Inc. has approved only the English language document.

This product is covered by the standard SEL 10-year warranty. For warranty details, visit selinc.com or contact your customer service representative.

SCHWEITZER ENGINEERING LABORATORIES, INC.

2350 NE Hopkins Court • Pullman, WA 99163-5603 U.S.A.

Tel: +1.509.332.1890 • Fax: +1.509.332.7990

selinc.com • info@selinc.com

