



# SEL-351-5, -6, -7 Protection System

## Optimize Protection, Automation, and Breaker Control



SEL-351 Protection System shown with front-panel USB port and SafeLock<sup>®</sup> trip/close pushbuttons with high-visibility breaker status LEDs.

## Major Features and Benefits

The SEL-351 Protection System provides an exceptional package of protection, monitoring, control, and fault locating features.

### Protection Functions

- Second-harmonic blocking secures relay during transformer energization.
- High-speed breaker failure element and native breaker failure logic enhance breaker failure detection.
- Phase, negative-sequence, residual-ground, and neutral-ground overcurrent elements with directional control optimize radial and looped network protection for lines and equipment. Load-encroachment logic provides additional security to distinguish between heavy load and three-phase faults.
- Under- and overfrequency and under- and overvoltage elements and powerful SELOGIC<sup>®</sup> control equations help implement load shedding and other control schemes.
- Built-in communications-assisted trip scheme logic permits fast trip times, reducing fault duration that adversely impacts system loads and power system equipment.
- SELOGIC control equations permit custom programming for traditional and unique protection and control functions.
- Directional power elements on SEL-351-7.
- Four levels of rate-of-change-of-frequency elements help detect rapid frequency changes to initiate load shedding or network decoupling.

## Automatic Reclosing and Synchronism Check

- Program as many as four shots of automatic reclosing with two selectable reclose formats.
- Control reclosing schemes for trip saving or fuse saving, and inhibit reclosing for hot-line maintenance.
- Supervise manual or automatic reclosing with synchronism check and voltage condition logic.

## Synchrophasors

- Improve operator awareness of system conditions with standard IEEE C37.118-2005 Level 1 synchrophasors at as many as 60 messages per second.
- Synchronize 128 sample-per-cycle oscillography and event reports to the microsecond to reconstruct complex disturbances. Synchronize meter reports to verify proper phasing.
- Use the “MRI of the power system” to replace state estimation with state measurement.

## Metering and Monitoring

- Eliminate expensive, separately mounted metering devices with built-in, high-accuracy metering and harmonic metering functions. Load Profile recording on SEL-351-6 and SEL-351-7.
- Improve maintenance scheduling using circuit breaker contact wear monitor and substation battery voltage monitors. Record relay and external trips and total interrupted current for each pole.
- Use alarm elements to inhibit reclosing and provide local and remote alarm indication.
- Analyze oscillographic and Sequential Events Recorder (SER) reports for rapid commissioning, testing, and post-fault diagnostics.
- Use unsolicited SER protocol to allow station-wide collection of binary SER messages with original time stamp for easy chronological analysis.
- Synchronize all reports with IRIG-B on the standard rear-panel BNC or on serial Port 2, from Simple Network Time Protocol (SNTP) on the standard or optional Ethernet connections, or via DNP serial or Ethernet protocols. Connect all possible time sources and the relay automatically selects the best.
- Use Voltage Sag, Swell, and Interrupt (VSSI) for power quality monitoring on SEL-351-7.

## Fault Locator

- Reduce fault location and repair time with built-in impedance-based fault locator and faulted phase indication.
- Efficiently dispatch line crews to quickly isolate line problems and restore service faster.

## Operator Interface and Controls

- Standard target LEDs announce trip and status indication and fault type.
- Two-line, large font rotating LCD display provides added operator information with programmable display points.
- Optional SafeLock<sup>®</sup> trip/close pushbuttons with high-visibility breaker status LEDs eliminate expensive panel-mounted breaker control switches and position indicating lights. The breaker status LED clusters are bright and easy to see from all viewing angles.

## Communications Protocols

- Optional IEC 61850 MMS and GOOSE. As many as 6 MMS sessions, guaranteed GOOSE performance with 24 subscriptions and 8 publications.
- Standard Modbus<sup>®</sup> with label-based map settings (serial and Ethernet—as many as three sessions).
- Standard DNP3 Level 2 with label-based map settings (serial and Ethernet—as many as six sessions).
- IEEE C37.118-2005 synchrophasor protocol (serial and Ethernet).

- ASCII, SEL Fast Meter, SEL Fast Message, SEL Unsolicited SER, SEL Fast Operate, and SEL Distributed Port Switch (LMD) serial protocols are all standard.
- Standard Telnet and integrated web server on Ethernet.
- Dual-channel MIRRORRED BITS<sup>®</sup> communications on SEL-351-6 and SEL-351-7.
- Parallel redundancy protocol (when supported by hardware).

## Communications Hardware

Two 10/100BASE-T Ethernet ports with RJ45 connector included.

- One or two 10/100BASE-FX Ethernet ports with LC multimode fiber-optic connectors optional.
- One 10/100BASE-T Ethernet port and one 10/100BASE-FX Ethernet port with LC multimode fiber-optic connectors optional.
- Front-panel high-speed USB Type-B port included.
- Front-panel EIA-232 DB-9 serial port included.
- Two rear-panel EIA-232 DB-9 ports included.
- One optional rear-panel EIA-485 port with five-position compression terminal block.
- One optional SEL-2812-compatible fiber-optic serial port.

## Single-Phase or Three-Phase Wye- or Delta-Connected Voltage Inputs

- Settings allow either single-phase or three-phase wye or three-phase delta voltage inputs.
- Single-phase voltage input permits phantom phase voltage for balanced three-phase metering and other limited voltage-dependent functions.
- The VS voltage input can be used for either synchronism-check or broken-delta (zero-sequence) voltage connection to the relay.

## Other Features and Options

**Table 1 SEL-351 Protection System Model Options**

Model	Complete Protection and Control Functions With ACSELERATOR QuickSet Support	Load Profile and MIRRORRED BITS Communications	Voltage Sag, Swell, Interruption Reports	Power Elements
SEL-351-5	x			
SEL-351-6	x	x		
SEL-351-7	x	x	x	x

- Available 750 KB of on-board storage space for ACSELERATOR QuickSet<sup>®</sup> SEL-5030 Software settings file, ACSELERATOR QuickSet design template, or anything else you choose.
- Expanded I/O is available. Order any one of the following I/O options:
  - Option X: No extra I/O board
  - Option 2: Additional 8 Inputs and 12 Standard Outputs
  - Option 4: Additional 16 Inputs and 4 Standard Outputs
  - Option 6: Additional 8 Inputs and 12 High Interrupting Current Outputs
- Nominal 5 A or 1 A current inputs: 5 A phase, 5 A neutral; 5 A phase, 1 A neutral; 1 A phase, 1 A neutral; 0.05 A neutral for nondirectional sensitive earth fault (SEF) protection; or 0.2 A neutral for directional ground protection on low-impedance grounded, ungrounded, high-impedance grounded, and Petersen Coil grounded systems.

**Note:** The 0.2 A nominal channel can also provide nondirectional SEF protection. The 0.05 A nominal neutral channel IN option is a legacy nondirectional SEF option.

# Functional Overview

Figure 1 shows the device numbers associated with the protection and control functions available on the SEL-351 Protection System, along with a list of the standard and optional monitoring and communications features.

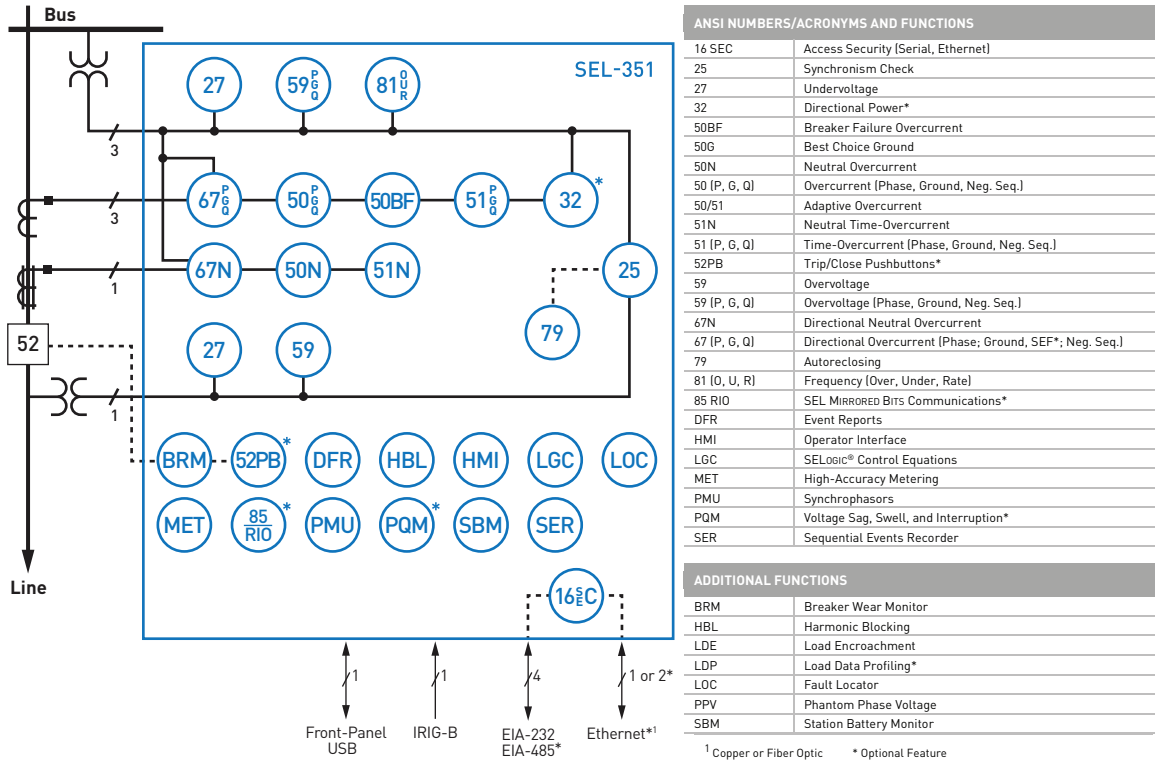

Figure 1 Functional Diagram

# Applications

The SEL-351 Protection System has many power system protection, monitoring, and control applications. Figure 2 shows some of the typical protection applications that are well suited for the SEL-351. The SEL-351 directional and nondirectional overcurrent functions can be used to protect virtually any power system circuit or device including lines, feeders, breakers, transformers, capacitor banks, reactors, and generators. Special relay versions can be ordered to provide nondirectional sensitive ground fault protection on high-impedance grounded systems, and directional overprotection ground fault protection on ungrounded, high-impedance grounded and tuned reactance (Petersen Coil) grounded systems.

Over/underfrequency, over/undervoltage, and synchronism-check elements are well suited for applications at distributed generation sites. Directional power elements in the SEL-351-7 model also make the relay suitable for utility/customer interface protection where customer generation is present.

Powerful SELOGIC control equations in all SEL-351 Protection System models can be used to provide custom protection and control applications. SEL Application Guides and technical support personnel are available to help with many unique applications.

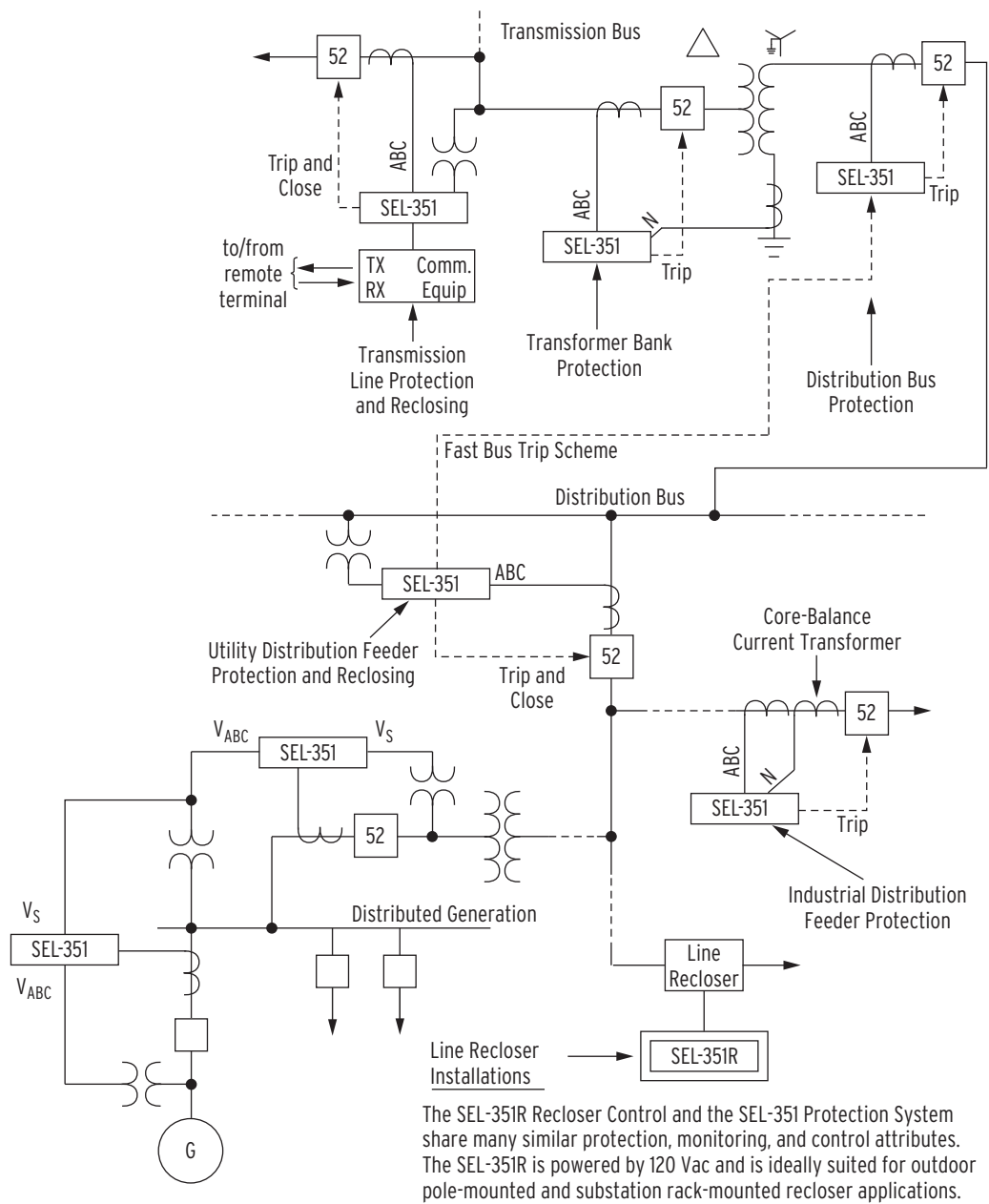

**Figure 2 SEL-351 Protection Systems Applied Throughout the Power System**

# Protection Features

## Overcurrent Elements

All SEL-351 models include numerous phase, negative-sequence, residual-ground, and neutral overcurrent elements, as shown in *Table 2*.

**Table 2 SEL-351 Phase, Negative-Sequence, Residual-Ground, and Neutral Overcurrent Elements**

Overcurrent Element Operating Quantity	Number of Elements	Directional Control	Torque Control	Definite-Time Delay
Maximum phase current (IA, IB, or IC)	1 inverse-time (51P)	Yes	Yes	NA
	6 instantaneous (50P1–50P6)	Yes, on first 4	Yes, on first 4	Yes, on first 4
Maximum phase-phase current (IAB, IBC, or ICA)	4 instantaneous (50PP1–50PP4)	No	No	No
Independent phase current	3 inverse-time (51A, 51B, 51C)	Yes	Yes	NA
Residual-ground current (3I0)	2 inverse-time (51G, 51G2)	Yes	Yes	NA
	6 instantaneous (50G1–50G6)	Yes, on first 4	Yes, on first 4	Yes, on first 4
Negative-sequence current (3I2)	1 inverse-time (51Q)	Yes	Yes	NA
	6 instantaneous (50Q1–50Q6)	Yes, on first 4	Yes, on first 4	Yes, on first 4
Neutral current (IN)	1 inverse-time (51N)	Yes	Yes	NA
	6 instantaneous (50N1–50N6)	Yes, on first 4	Yes, on first 4	Yes, on first 4

Inverse-time overcurrent element settings include a wide and continuous pickup current range, continuous time-dial setting range, and time-current curve choices from both US (IEEE) and IEC standard curves shown in *Table 3*.

**Table 3 Inverse Time-Overcurrent Curves**

IEEE	IEC
Moderately Inverse (U1)	Standard Inverse (C1)
Inverse (U2)	Very Inverse (C2)
Very Inverse (U3)	Extremely Inverse (C3)
Extremely Inverse (U4)	Long-Time Inverse (C4)
Short-Time Inverse (U5)	Short-Time Inverse (C5)

Use multiple inverse curves to coordinate with downstream reclose fast and delay curves. Sequence coordination logic is also included to provide coordination between fast and delayed curves on the SEL-351 and downstream reclosers. *Figure 3* represents an SEL-351 coordinated to a downstream SEL-351R Recloser Control. Inverse-time relay curve settings include a wide and continuous pickup current and time-dial (vertical multiplier) range.

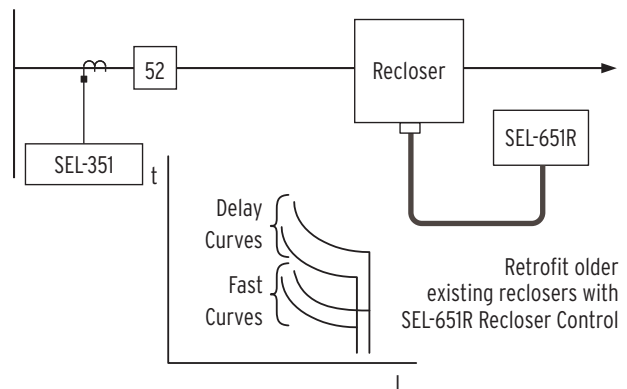

**Figure 3 Coordinate Overcurrent Protective Devices**

The SEL-351 Protection System inverse-time overcurrent relay curve settings offer two reset characteristic choices for each element. Setting EM Reset Delay = Y emulates electromechanical induction disc elements, where the reset time depends on the time-dial setting, the percentage of disc travel, and the amount of current. Setting EM Reset Delay = N resets the elements immediately if current drops below pickup for at least one cycle.

## Overcurrent Elements for Phase Fault Detection

The SEL-351 Protection System provides the tools necessary to provide sensitive fault protection, yet accommodate heavily loaded circuits. Where heavy loading prevents the phase overcurrent elements from being set sufficiently sensitive to detect lower magnitude phase-to-ground faults, residual-ground overcurrent elements are available to provide sensitive ground fault protection without tripping under balanced heavy load conditions. Likewise, when heavy loading prevents the phase overcurrent elements from being set sufficiently sensitive to detect lower magnitude phase-to-phase faults, negative-sequence overcurrent elements are available to provide more sensitive phase-to-phase fault detection without tripping under balanced heavy load conditions. Phase overcurrent element pickup can be set high to accommodate heavy load, yet remain sensitive to higher magnitude three-phase faults. Block any element during transformer inrush with programmable second-harmonic blocking.

On extremely heavily loaded feeders, when phase overcurrent elements cannot be set to provide adequate three-phase fault sensitivity and also accommodate load, the SEL-351 load-encroachment logic adds security. This logic allows you to set the phase overcurrent elements below peak load current to see end-of-line phase faults in heavily loaded feeder applications. This load-encroachment logic uses positive-sequence load-in and load-out elements to discriminate between load and fault conditions based on the magnitude and angle of the positive-sequence impedance (*Figure 4*). When the measured positive-sequence load impedance ( $Z_1$ ) resides in a region defined by the load-encroachment settings, load-encroachment logic blocks the phase overcurrent elements. As *Figure 4* shows, when a phase fault occurs,  $Z_1$  moves from a load region to the line angle and allows the phase overcurrent elements to operate.

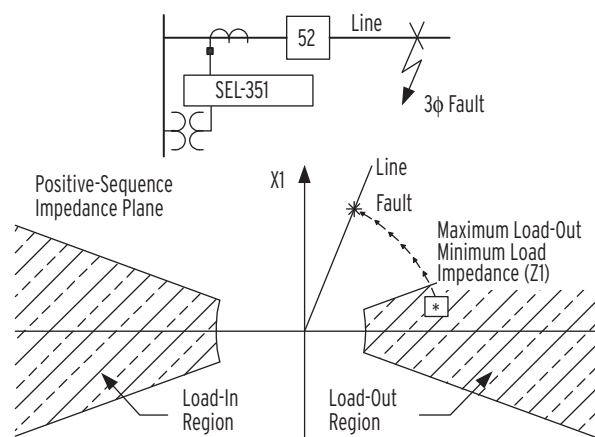

**Figure 4** Load-Encroachment Characteristics

## Overcurrent Elements for Ground Fault Detection

Residual-ground ( $I_G$ ) and neutral ( $I_N$ ) overcurrent elements detect ground faults. Increase security by controlling these elements using optoisolated inputs or the internal ground directional element. The SEL-351 Protection System includes patented Best Choice Ground Directional Element™ logic, providing a selection of negative-sequence impedance, zero-sequence impedance, and zero-sequence current polarizing techniques for optimum directional ground element control.

## High-Speed Breaker Failure Protection

Detect a failed circuit breaker quickly with built-in breaker failure detection elements and logic. Dropout of conventional overcurrent elements can be extended by subsidence current, especially following high-current faults. The high-speed 50BF element drops out less than one cycle after successful breaker operation, even with subsidence current. Faster dropout times mean faster breaker failure detection and clearing times. Use the breaker failure trip and retrip timers to trigger dedicated breaker failure trip logic. Built-in breaker failure elements and logic save valuable programmable logic for other tasks.

## Connect a Single-Phase Voltage Input or a Three-Phase Voltage With Wye or Open-Delta Connected Potential Transformers

With a single-phase voltage input connected, the SEL-351 Protection System creates phantom phase voltages to emulate balanced three-phase voltages for metering. The single-phase voltage must be connected to VA and N, as shown in *Figure 5*, but can come from any phase or phase-to-phase voltage source. Make Global setting PTCOON = SINGLE and set PHANTV to the desired phase or phase-to-phase voltage to identify the single-phase voltage source for proper metering. Single-phase voltage input also permits some voltage-dependent protection functions. See *Table 4* for more details. Other nonprotection functions, including fault locating and Voltage Sag, Swell, Interrupt (SEL-351-7 only) are not available with only single-phase voltage connected.

Three-phase voltages from either wye-connected (four-wire) or open-delta-connected (three-wire) sources can be applied to three-phase voltage inputs VA, VB, VC, and N, as shown in *Figure 5*. You only need to make a Global setting (PTCOON = WYE or PTCOON = DELTA, respectively) and an external wiring change—

no internal relay hardware changes or adjustments are required. Three-phase, wye-connected voltage inputs permit full use of voltage-dependent protection functions. Some limitations exist with delta-connected voltage inputs. See *Table 4* for more details.

**Table 4 Voltage-Dependent Protection Function Availability Based on Voltage Source Connection**

Voltage-Dependent Protection Functions	Voltage Source		
	Single-phase	Three-phase wye	Three-phase delta
Phase Over/Undervoltage	Yes	Yes	No
Phase-to-Phase Over/Undervoltage	No	Yes	Yes
Sequence Over/Undervoltage	No	Yes	Positive and negative
Over/Underfrequency	Yes	Yes	Yes
Load Encroachment	No	Yes	Yes
Phase and Negative-Sequence Directional Overcurrent	No	Yes	Yes
Ground Directional Overcurrent	Yes <sup>a</sup>	Yes	Yes
Communications-Assisted Trip Logic	No	Yes	Yes
Loss-of-Potential Logic	No	Yes	Yes
Single-Phase Directional Power (SEL-351-7 only)	Yes	Yes	No
Three-Phase Directional Power (SEL-351-7 only)	No	Yes	Yes

<sup>a</sup> Requires 3I0 current polarization on IN, or 3V0 voltage polarization on VS input.

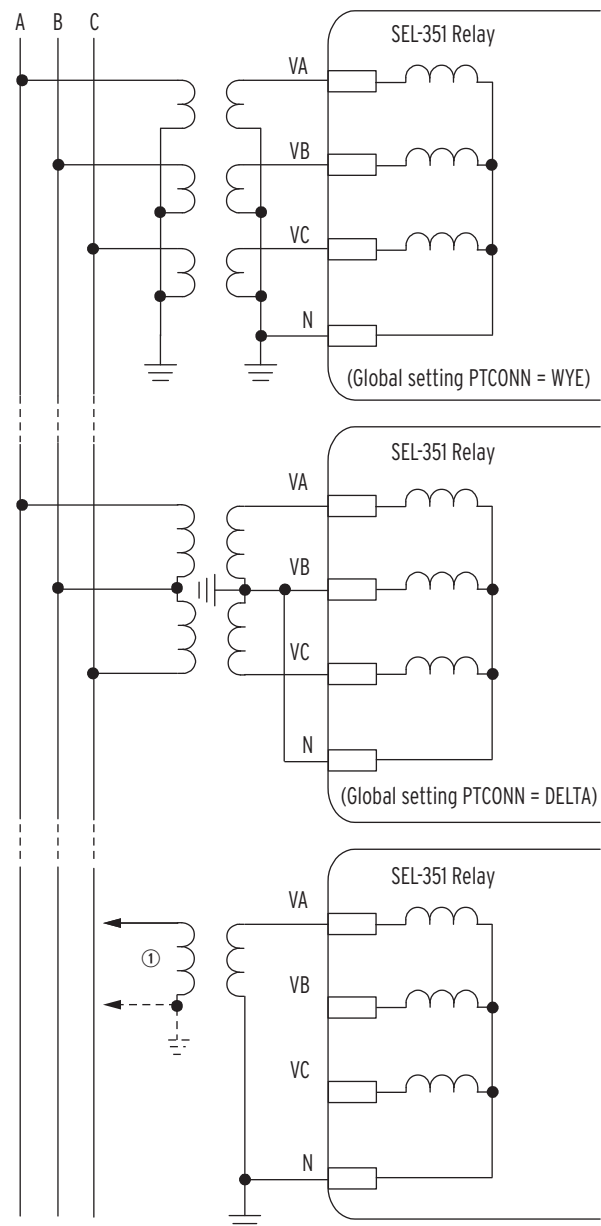

① Connections	PHANTV =
VA-G	VA
VB-G	VB
VC-G	VC
VA-B	VAB
VB-C	VBC
VC-A	VCA

Global settings:  
PTCONN = SINGLE  
PHANTV = (see ①)

A single-phase voltage can be connected to provide phantom three-phase voltages for metering.

**Figure 5 Connect Wye or Open-Delta Voltage to SEL-351 Three-Phase Voltage Inputs or Connect any Single-Phase or Phase-to-Phase Voltage to VA and N**



## Connect to Synchronism-Check or Broken-Delta Voltage

Traditionally, single-phase voltage (phase-to-neutral or phase-to-phase) is connected to voltage input VS/NS for synchronism check across a circuit breaker (or hot/dead-line check), as shown in *Figure 23*.

Alternatively, voltage input VS/NS can be connected to a broken-delta voltage source, as shown in *Figure 6*. This broken-delta connection provides a zero-sequence voltage source (3V<sub>0</sub>)—useful when zero-sequence voltage is not available via the three-phase voltage inputs VA, VB, VC, and N, (e.g., when open-delta connected voltage is applied to the three-phase voltage inputs—see *Figure 5*). Zero-sequence voltage is used in zero-sequence voltage-polarized ground directional elements and in the directional protection for Petersen Coil grounded systems.

Choosing between synchronism-check or broken-delta (3V<sub>0</sub>) voltage source operation for voltage input VS/NS requires only a Global setting (VSCONN = VS or VSCONN = 3V<sub>0</sub>, respectively) and an external wiring change—no internal relay hardware changes or adjustments are required. Therefore, a single SEL-351 model can be used in either traditional synchronism-check applications or broken-delta voltage applications.

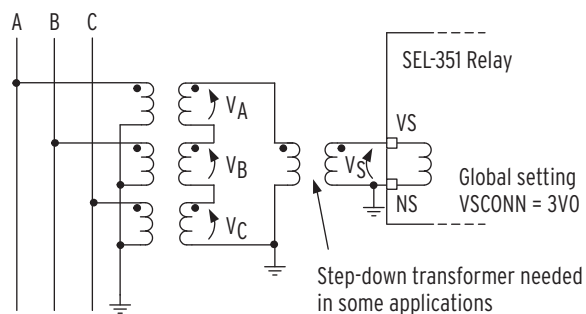

**Figure 6** Broken-Delta Connection to SEL-351 Voltage Input VS/NS

## Directional Elements Increase Sensitivity and Security

Phase and ground directional elements are standard. An automatic setting mode (E32 = AUTO) sets all directional threshold settings based on replica positive-sequence and zero-sequence line impedance settings (Z1MAG, Z1ANG, Z0MAG, and Z0ANG) for line protection applications. For all nonlinear protection applications, set E32 = Y to enable and set appropriate directional element thresholds.

Phase directional elements provide directional control to the phase- and negative-sequence overcurrent elements. Phase directional characteristics include positive-sequence and negative-sequence directional elements that work together. The positive-sequence directional element memory provides a reliable output for close-in, forward or reverse three-phase faults where each phase voltage is zero.

Ground directional elements provide directional control to the residual-ground and neutral overcurrent elements. The patented negative-sequence and zero-sequence impedance directional elements and the zero-sequence current directional element use the same principles proven in our SEL transmission line relays. Our patented Best Choice Ground Directional Element logic selects the optimum ground directional element based on the ORDER setting you provide.

## Directional Protection for Various System Grounding Practices

Current channel IN, ordered with an optional 0.2 A secondary nominal rating, provides directional ground protection for the following systems:

- Ungrounded systems
- High-impedance grounded systems
- Petersen Coil grounded systems
- Low-impedance grounded systems

This optional directional control allows the faulted feeder to be identified on a multifeder bus, with an SEL-351 on each feeder (*Figure 7*). Alarm or trip for the ground fault condition with sensitivity down to 5 mA secondary.

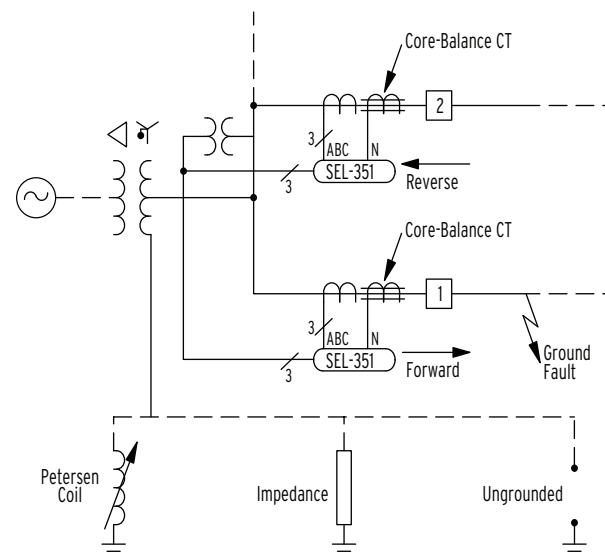

**Figure 7** Apply SEL-351 Relays to Petersen Coil Grounded, Impedance-Grounded, and Ungrounded Systems for Directional Control

## Loss-of-Potential Logic Supervises Directional Elements

Voltage-polarized directional elements rely on valid input voltages to make correct decisions. The SEL-351 includes loss-of-potential (LOP) logic that detects one, two, or three blown potential fuses. For an LOP condition, you can choose to disable all directional elements (set ELOP = Y1), disable all reverse directional elements and enable forward directional elements as nondirectional (set ELOP = Y), or choose not to affect the directional element operation with LOP logic (set ELOP = N).

This patented LOP logic is unique, as it does not require settings and is universally applicable. The LOP logic does not monitor the VS voltage input, nor does it affect zero-sequence voltage-polarized ground directional elements when a broken-delta 3V0 voltage source is connected to the VS-NS terminals. The LOP logic is not available when only single-phase voltage is applied to the relay.

## Power Elements

Four independent directional power elements are available in the SEL-351-7. For wye-connected applications, you can enable either single-phase power elements or three-phase power elements (but not both). For delta-connected applications, you can enable three-phase power elements only. For applications with only single-phase voltage applied, only the single-phase power elements are available. Each enabled power element can be set to detect real power or reactive power. With SELOGIC control equations, the power elements provide a wide variety of protection and control applications. Typical applications are:

- Overpower and/or underpower protection and control
- Reverse power protection and control
- VAR control for capacitor banks

## Programmable Torque-Control Feature Handles Cold-Load Energization

When a feeder is re-energized following a prolonged outage, lost load diversity causes large phase currents (cold-load inrush). Avoid phase overcurrent element misoperation during cold-load inrush by programming cold-load block elements into the phase overcurrent element torque controls. One example of a cold-load block element is a time-delayed 52 status (long time-delay pickup and dropout timer with 52 as the input). An alternative is to detect the long outage condition (breaker

open) automatically, and temporarily switch to a setting group with higher phase overcurrent element pickup thresholds.

## Harmonic Blocking Elements Secure Protection During Transformer Energization

Transformer inrush can cause sensitive protection to operate. Use the second-harmonic blocking feature to detect an inrush condition and block selected tripping elements until the inrush subsides. Select the blocking threshold as a percentage of fundamental current, and optimize security and dependability with settable pickup and dropout times. Use the programmable torque-control equation to only enable the blocking element immediately after closing the breaker.

## Voltage and Frequency Elements for Extra Protection and Control Under/Overvoltage Elements

Phase (wye-connected and single-phase only) or phase-to-phase and single-phase undervoltage (27) and overvoltage (59) elements in the SEL-351 create the following protection and control schemes:

- Torque control for the overcurrent protection
- Hot-bus (line), dead-bus (line) recloser control
- Blown transformer high-side fuse detection logic
- Trip/alarm or event report triggers for voltage sags and swells
- Undervoltage (27) load shedding scheme. Having both 27 and 81U load shedding schemes allows detection of system MVAR- and MW-deficient conditions.
- Control schemes for capacitor banks

Use the following undervoltage and overvoltage elements, associated with the  $V_S$  voltage channel, for additional control and monitoring:

- Hot-line/dead-line recloser control
- Ungrounded capacitor neutrals
- Ground fault detection on delta systems
- Generator neutral overvoltage
- Broken-delta zero-sequence voltage (see *Figure 6*)

## Sequence Voltage Elements

Independently set positive-, negative-, and zero-sequence voltage elements provide protection and control. Applications include transformer bank single-phase trip schemes and delta-load back-feed detection scheme for dead-line recloser control. Note that zero-sequence

elements are not available when the relay is delta connected, and no sequence elements are available when only single-phase voltage is connected.

## Under/Overfrequency Protection

Six levels of secure under- (81U) or overfrequency (81O) elements detect true frequency disturbances. Use the independently time-delayed output of these elements to shed load or trip local generation. Phase undervoltage supervision prevents undesired frequency element operation during faults.

Implement an internal multistage frequency trip/restore scheme at each breaker location using the multiple under/overfrequency levels. This avoids the cost of wiring a complicated trip and control scheme from a separate frequency relay.

## Rate-of-Change-of-Frequency Protection

Four independent rate-of-change-of-frequency elements are provided with individual time delays for use when frequency changes occur, such as when there is a sudden imbalance between generation and load. They call for control action or switching action such as network decoupling or load shedding. Each element includes logic to detect either increasing or decreasing frequency.

# Operator Controls and Reclosing

## Optional SafeLock Trip/Close Pushbuttons and Indicating LEDs

Optional SafeLock trip/close pushbuttons (see *Figure 8*) and bright indicating LEDs allow breaker control independent of the relay. The trip/close pushbuttons are electrically separate from the relay, operating even if the relay is powered down. Make the extra connections at terminals Z15 through Z22. See *Figure 24* through *Figure 28* for front-panel and rear-panel views. *Figure 9* shows one possible set of connections.

The trip/close pushbuttons incorporate an arc suppression circuit for interrupting dc trip or close current to protect the internal electrical contacts. To use these pushbuttons with ac trip or close circuits, disable the arc suppression for either pushbutton by changing jumpers inside the SEL-351. The operating voltage ranges of the BREAKER CLOSED and BREAKER OPEN indicating LEDs are also jumper selectable.

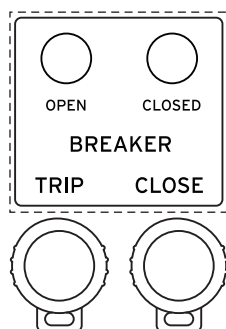

**Figure 8** SafeLock Trip/Close Pushbuttons and Indicators

**Note:** The SafeLock trip/close pushbuttons and breaker status LEDs always have configurable labels. Dashed lines outline the configurable label area where text can be changed.

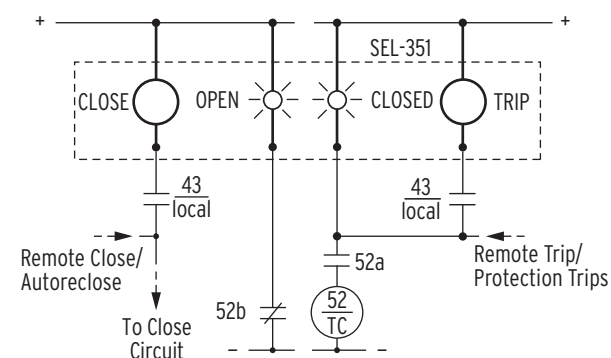

**Figure 9** Optional SafeLock Trip/Close Pushbuttons and Indicating LEDs

## Local and Remote Control

Under certain operating conditions, such as performing distribution feeder switching, it is desirable to temporarily disable ground fault protection. This is accomplished in a variety of ways using SELOGIC control equations with local and remote control. As shown in *Figure 10*, achieve remote disable/enable control using an optoisolated input or the serial communications port. The local control switch function handles local disable/enable control. Output contacts, serial ports and the local LCD display points indicate ground relay operating status. Local and remote control capabilities require programming SELOGIC control equations.

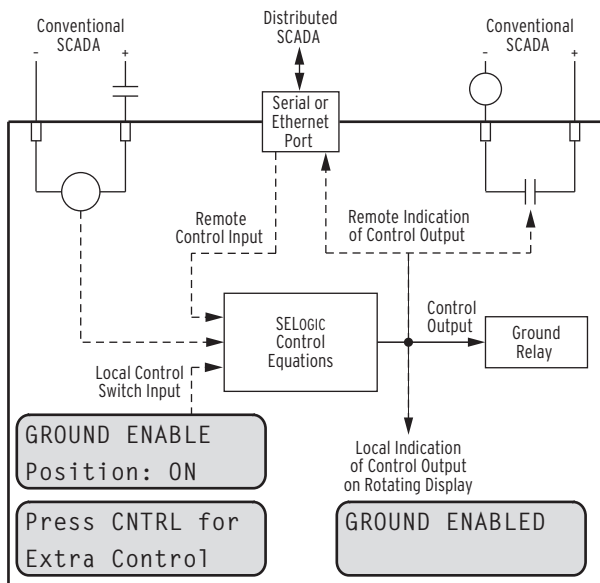

**Figure 10** Local and Remote Control Using SELogic Control Equations (Ground Relay Example)

## Programmable Autoreclosing

The SEL-351 autoreclose flexibility allows many different reclosing strategies to meet traditional and custom requirements. Traditional applications include sequence coordination, fuse-saving, and trip-saving schemes. The SEL-351 can autoreclose a circuit breaker as many as four times before lockout. Use SELOGIC control equations to enable and disable reclosing, define reclose initiation and supervision conditions, shot counter advance and drive-to-lockout conditions, close supervision and close failure conditions, and open interval timer start and stall conditions. Separate time delays are available for reset-from-successful-reclose and reset-from-lockout conditions. The reset timer can be stalled if the relay detects an overcurrent condition after the breaker closes to prevent the recloser from resetting before the relay trips on a permanent slow-clearing fault.

Program the SEL-351 to perform unconditional reclose, conditional reclose using voltage check and synchrocheck functions, and even autosynchronizing when the two systems are asynchronous. Select from two recloser supervision failure modes: one drives to lockout, the other advances to the next available shot. The front-panel LEDs (RESET, CYCLE, and LOCKOUT) track the recloser state.

## Relay and Logic Settings Software

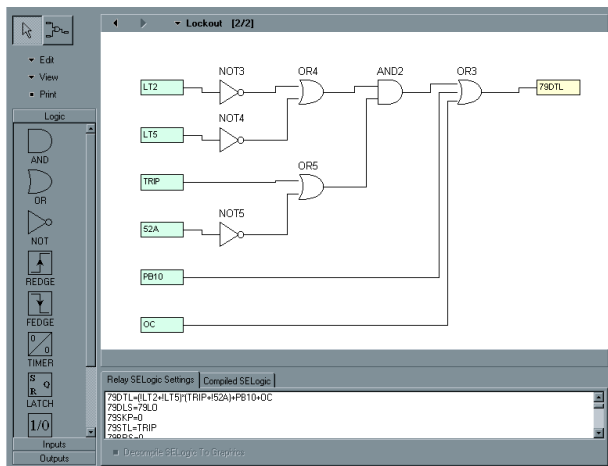

**Figure 11** ACCELERATOR QuickSet Software Screen

The ACCELERATOR QuickSet software program uses the Microsoft® Windows® operating system to simplify settings and provide analysis support for the SEL-351.

Use ACCELERATOR QuickSet to create and manage relay settings and analyze events:

- Develop settings off-line with an intelligent settings editor that only allows valid settings.
- Create SELOGIC control equations with a drag and drop graphical editor and/or text editor.

- Use online help to assist with configuring proper settings.
- Organize settings with the relay database manager.
- Load and retrieve settings using a simple PC communications link.
- Enter settings into a settings template generated with licensed versions of SEL ACCELERATOR QuickSet. Send resulting settings and the template to the relay with a single action. When reading settings from the relay, ACCELERATOR QuickSet also retrieves the template and compares the settings generated by the template to those in use by the relay, alerting you to any differences.
- Analyze power system events with the integrated waveform and harmonic analysis tools.

Use ACCELERATOR QuickSet to aid with monitoring, commissioning, and testing the SEL-351:

- Use the human-machine interface (HMI) to monitor meter data, Relay Word bits, and output contacts status during testing.
- Use the PC interface to remotely retrieve breaker wear, voltage sag/swell/interruption reports, and other power system data.

# Integrated Web Server

An embedded web server is included in every SEL-351 relay. Browse to the relay with any standard web browser to safely read settings, verify relay self-test status, inspect meter reports, and read relay configuration and event history. The web server allows no control or modification actions at Access Level 1 (ACC), so users can be confident that an inadvertent button press will have no adverse effects. *Figure 12* shows an example of a settings display web page.

The web server allows users with the appropriate engineering access level (2AC) to upgrade the firmware over an Ethernet connection. An Ethernet port setting

enables or disables this feature, with the option of requiring front-panel confirmation when the file is completely uploaded.

The SEL-351 firmware files contain cryptographic signatures that enable the SEL-351 to recognize official SEL firmware. A digital signature, computed using the Secure Hash Algorithm 1 (SHA-1), is appended to the compressed firmware file. Once the firmware is fully uploaded to the relay, the relay verifies the signature using a Digital Signature Algorithm security key that SEL stored on the device. If the signature is valid, the firmware is upgraded in the relay. If the relay cannot verify the signature, it reverts back to the previously installed firmware.

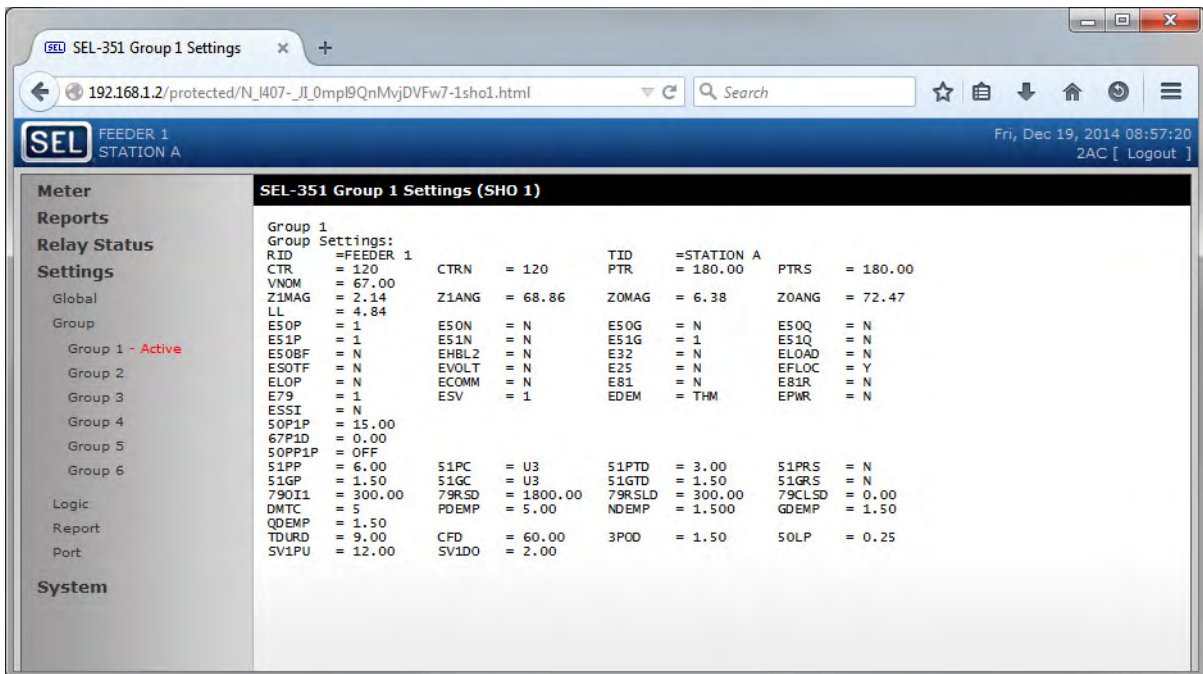

Figure 12 Settings Display Web Page

## Metering and Monitoring

Table 5 Metering Capabilities<sup>a</sup> (Sheet 1 of 2)

Quantities	Description
Currents $I_{A,B,C,N}$ , $I_G$	Input currents, residual-ground current ( $I_G = 3I_0 = I_A + I_B + I_C$ ).
Voltages $V_{A,B,C}$	Wye-connected and single-phase voltage inputs.
Voltages $V_{AB,BC,CA}$	Delta-connected voltage inputs, or calculated from wye-connected voltage inputs.
Voltage $V_S$	Synchronism-check or broken-delta voltage input.
Harmonics and THD	Current and voltage rms, THD, and harmonics to the 16th harmonic.
Power MW <sub>A,B,C,3P</sub> , MVAR <sub>A,B,C,3P</sub>	Single- <sup>b</sup> and three-phase megawatts and megavars.

**Table 5 Metering Capabilities<sup>a</sup> (Sheet 2 of 2)**

Quantities	Description
Energy MWh <sub>A,B,C,3P</sub> MVARh <sub>A,B,C,3P</sub>	Single- <sup>b</sup> and three-phase megawatt-hours and megavar-hours.
Power Factor PF <sub>A,B,C,3P</sub>	Single- <sup>b</sup> and three-phase power factor; leading or lagging.
Sequence I <sub>1</sub> , 3I <sub>2</sub> , 3I <sub>0</sub> , V <sub>1</sub> , V <sub>2</sub> , 3V <sub>0</sub>	Positive-, negative-, and zero-sequence currents and voltages. <sup>c</sup>
Frequency, FREQ (Hz)	Instantaneous power system frequency (monitored on channel V <sub>A</sub> ).
Power Supply Vdc	Battery voltage
Demand and Peak Currents, I <sub>A,B,C,N,G</sub> , 3I <sub>2</sub>	Phase, neutral, ground, and negative-sequence currents
Demand and Peak Power, MW <sub>A,B,C,3P</sub> MVAR <sub>A,B,C,3P</sub>	Single- and three-phase megawatts and megavars, in and out

<sup>a</sup> If single-phase or true three-phase voltage is not connected, voltage, MW/MVAR, MWh/MVARh, and power factor metering values are not available. With single-phase voltage connected and Global setting PTCONN = SINGLE, the relay measures the single-phase voltage and calculates other phase voltages and power measurements assuming balanced three-phase voltage.  
<sup>b</sup> Note that single-phase power, energy, and power factor quantities are not available when delta-connected PTs are used.  
<sup>c</sup> Sequence voltages are not metered with only single-phase voltage connected and Global setting PTCONN = SINGLE.

## Complete Metering Capabilities

The SEL-351 provides extensive and accurate metering capabilities. See *Specifications on page 27* for metering and power measurement accuracies.

As shown in *Table 5*, metered quantities include phase voltages and currents (including demand currents); sequence voltages and currents; power (including

demand), frequency, and energy; and maximum/minimum logging of selected quantities. The relay reports all metered quantities in primary quantities (current in A primary and voltage in kV primary).

The SEL-351 also includes harmonic meters, Total Harmonic Distortion (THD), and rms metering through the 16th harmonic.

=>MET H <Enter>

```

FEEDER 1                               Date: 11/13/09   Time: 13:19:22.102
STATION A

      Currents (A pri)                   Voltages (kV pri)
      IA   IB   IC   IN   VA   VB   VC   VS
THD (%)  19   22   11   0    2    4    2    2
RMS      35.40 41.79 38.60 0.00 21.61 21.54 21.50 21.50
Fund.    34.77 40.80 38.35 0.00 21.60 21.52 21.50 21.50

Harmonic
2 (%)    0    0    0    0    0    0    0    0
3 (%)    7   14   4    0    0    4    0    0
4 (%)    0    0    0    0    0    0    0    0
5 (%)    3   12   6    0    2    0    0    0
6 (%)    0    0    0    0    0    0    0    0
7 (%)   13   4    2    0    0    0    2    2
8 (%)    0    0    0    0    0    0    0    0
9 (%)    5    6    4    0    0    0    0    0
10 (%)   0    0    2    0    0    0    0    0
11 (%)   6    6    0    0    0    0    0    0
12 (%)   0    0    0    0    0    0    0    0
13 (%)   3    3    6    0    0    0    0    0
14 (%)   0    0    0    0    0    0    0    0
15 (%)   2    3    0    0    0    0    0    0
16 (%)   8    4    0    0    0    0    0    0
=>
    
```

## Load Profile

The SEL-351-6 and -7 feature a programmable Load Profile (LDP) recorder that records as many as 15 metering quantities into nonvolatile memory at fixed time intervals. The LDP saves several days to several weeks of the most recent data depending on the LDP settings.

## Event Reporting and Sequential Events Recorder (SER)

Event Reports and the SER simplify post-fault analysis and improve understanding of simple and complex protective scheme operations. In response to a user-selected trigger, the voltage, current, frequency, and element status information contained in each event report confirms relay, scheme, and system performance for



every fault. The Global setting LER determines if the relay stores 15-cycle, 30-cycle, or 60-cycle event reports. The relay stores the most recent eleven 60-cycle, twenty-three 30-cycle, or forty-four 15-cycle event reports in nonvolatile memory; a total of 11 seconds of oscillography. The relay always appends relay settings to the bottom of each event report.

The following event report formats are available:

- 1/4-cycle, 1/16-cycle, 1/32-cycle, or 1/128-cycle resolution
- Unfiltered or filtered analog
- ASCII or Compressed ASCII

The relay SER feature stores the latest 1024 entries. Use this feature to gain a broad perspective at a glance. An SER entry helps to monitor input/output change-of-state occurrences, element pickup/dropout, and recloser state changes.

The IRIG-B time-code input synchronizes the SEL-351 time to within 1 ms of the time-source input. A convenient source for this time code is an SEL communications processor (combining data and IRIG signals via Serial Port 2 on the SEL-351) or an SEL GPS clock connected to the high-accuracy BNC IRIG-B connector on the SEL-351 rear panel. The optional SEL-2812-compatible fiber-optic serial port is also an IRIG-B source when paired with a compatible serial transceiver which transmits IRIG-B.

## Synchrophasor Measurements

Send synchrophasor data using IEEE C37.118-2005 protocol to SEL synchrophasor applications. These include the SEL-3306 Synchrophasor Processor, SEL-3378 Synchrophasor Vector Processor (SVP), SEL-3530 Real-Time Automation Controller (RTAC), and the SEL SYNCHROWAVE® Central software suite. The SEL-3306 Synchrophasor Processor time correlates data from multiple SEL-351 relays and concentrates the result into a single output data stream. The SEL-3378 SVP enables control applications based on synchrophasors. Directly measure the oscillation modes of your power system. Act on the result. Properly control islanding of distributed generation using wide-area phase angle slip and acceleration measurements. With the SVP you have the power to customize synchrophasor control application based on the unique requirements of your power system. Then use SEL SYNCHROWAVE software to archive and display wide-area system measurements, which are precisely time-aligned using synchrophasor technology.

The data rate of SEL-351 synchrophasors is selectable with a range of one to sixty messages per second. This flexibility is important for efficient use of communications capacity. The SEL-351 phasor

measurement accuracy meets the highest IEEE C37.118-2005 Level 1 requirement of 1 percent total vector error (TVE). This means you can use the low-cost SEL-351 in any application that otherwise would have required purchasing a separate dedicated phasor measurement unit (PMU).

Backward compatibility with the SEL Fast Message Protocol is maintained in the SEL-351. Send data from one message per second to slower rates such as one message per minute using this protocol. The slow data rates are useful for integration into an existing SCADA scan rate. Use with the SEL communications processors, or the SEL-3530 RTAC, to change nonlinear state estimation into linear state estimation. If all necessary lines include synchrophasor measurements then state estimation is no longer necessary. The system state is directly measured.

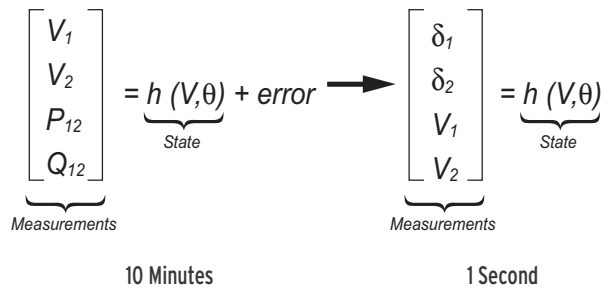

**Figure 13 Synchrophasor Measurements Turn State Estimation Into State Measurement**

## Improve Situational Awareness

Provide improved information to system operators. Advanced synchrophasor-based tools provide a real-time view of system conditions. Use system trends, alarm points, and preprogrammed responses to help operators prevent a cascading system collapse and maximize system stability. Awareness of system trends provides operators with an understanding of future values based on measured data.

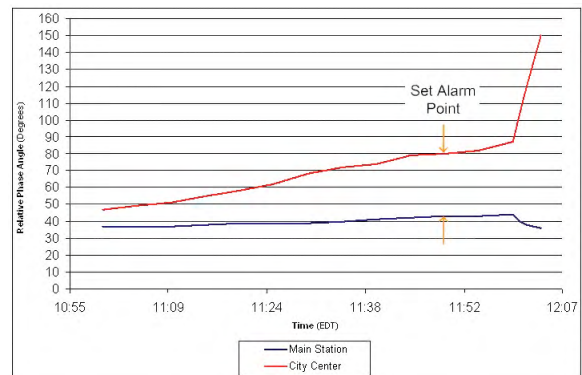

**Figure 14 Visualization of Phase Angle Measurements Across a Power System**

- Increase system loading while maintaining adequate stability margins.
- Improve operator response to system contingencies such as overload conditions, transmission outages, or generator shutdown.
- Advance system knowledge with correlated event reporting and real-time system visualization.
- Validate planning studies to improve system load balance and station optimization.

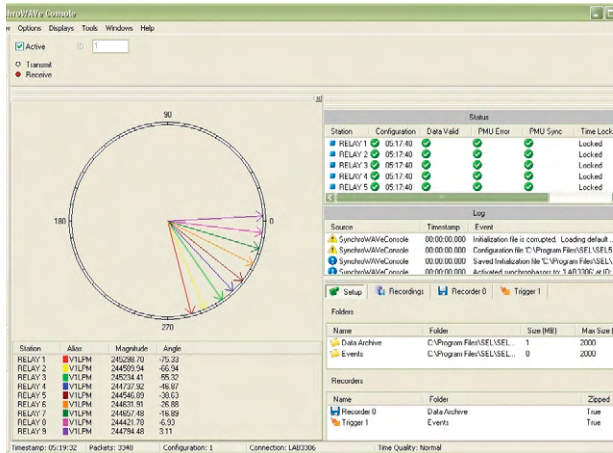

**Figure 15 SEL-5078 SYNCHROWAVE Console Real-Time, Wide-Area Visualization Tool**

## Voltage Sag, Swell, Interruption Records

The SEL-351-7 can perform automatic voltage disturbance monitoring for three-phase systems. (This function is not available when only single-phase voltage is connected and PTCOON = SINGLE.) The Sag/Swell/Interruption (SSI) recorder uses the SSI Relay Word bits to determine when to start (trigger) and when to stop recording. The SSI recorder uses nonvolatile memory, so de-energizing the relay will not erase any stored SSI data.

The recorded data is available through the SSI report, which includes date, time, current, voltage, and Voltage Sag/Swell/Interruption (VSSI) element status during voltage disturbances, as determined by programmable settings, VINT, VSAG, and VSWELL. When the relay is recording a disturbance, entries are automatically added to the SSI report at one of four rates: once per quarter-cycle, once per cycle, once per 64 cycles, or once per day.

## Demand Current Threshold Alarm

Use overload and unbalanced current threshold alarms for phase, negative-sequence, neutral, and residual demand currents.

Two types of demand-measuring techniques are offered: thermal and rolling.

Select the demand ammeter time constant from 5 to 60 minutes.

## Circuit Breaker Operate Time and Contact Wear Monitor

Circuit breakers experience mechanical and electrical wear every time they operate. Intelligent scheduling of breaker maintenance takes into account manufacturer's published data of contact wear versus interruption levels and operation count. With the breaker manufacturer's maintenance curve as input data, the SEL-351 breaker monitor feature compares this input data to the measured (unfiltered) ac current at the time of trip and the number of close to open operations.

Every time the breaker trips, it integrates the measured current information. When the result of this integration exceeds the breaker wear curve threshold (*Figure 16*) the relay alarms via output contact, serial port, or front-panel display. This kind of information allows timely and economical scheduling of breaker maintenance.

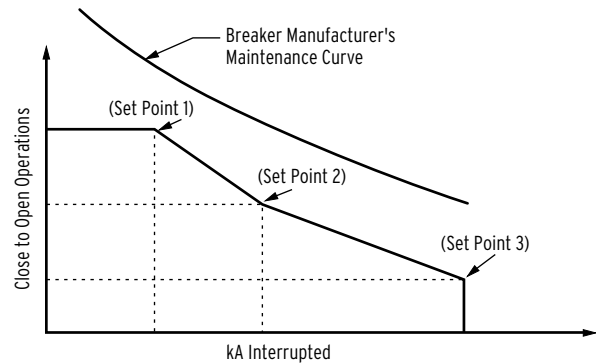

**Figure 16 Breaker Contact Wear Curve and Settings**

The relay monitors and records electrical and mechanical breaker operate times and minimum dc voltage for open and close operations. Use the settable alarm thresholds to issue warning alarms for slow mechanical or electrical trip or close operations. Inspect reports for the most recent operation, or gather trending data for as many as 128 previous operations. Retrieve breaker monitor reports through FTP or Manufacturing Message Specification (MMS) file transfer.

## Substation Battery Monitor

The SEL-351 measures and reports the substation battery voltage connected to the power supply terminals. The relay includes two programmable threshold comparators and associated logic for alarm and control. For example, if the battery charger fails, the measured dc falls below a programmable threshold. The SEL-351 alarms operations personnel before the substation battery



voltage falls to unacceptable levels. Monitor these thresholds with SEL communications processors and trigger messages, telephone calls, or other actions.

The measured dc voltage appears in the METER display and the VDC column of the event report. Use the event report column data to see an oscillographic display of the battery voltage. You can see how much the substation battery voltage drops during trip, close, and other control operations.

## Fault Locator

The SEL-351 provides a valuable estimate of fault location even during periods of substantial load flow. The fault locator uses fault type, replica line impedance settings, and fault conditions to calculate fault location without communications channels, special instrument transformers, or pre-fault information. This feature contributes to efficient dispatch of line crews and fast restoration of service. The fault locator requires three-

phase voltage inputs. Wye-connected voltages are required for phase and ground fault distance calculations. Only phase fault distance calculations are available with delta-connected voltages. The fault locator is not available when no voltage or single-phase voltages are connected. The fault locator also does not operate for ground faults on ungrounded, high-impedance grounded, or Petersen Coil grounded systems.

## Automation

### Flexible Control Logic and Integration Features

The SEL-351 Protection System is equipped with two 10/100BASE-T Ethernet ports on the rear panel, a front-panel USB port, and three independently-operated serial ports: one EIA-232 serial port on the front panel and two EIA-232 serial ports on the rear panel. Communications port ordering options include replacing the standard metallic Ethernet ports with a 100BASE-FX optical Ethernet port, dual-redundant 100BASE-FX optical Ethernet ports, or with one 10/100BASE-T metallic and one 100BASE-FX fiber port. Additional options include an isolated EIA-485 rear-panel port or SEL-2812-compatible rear-panel fiber-optic port. The USB Type-B port on the front panel allows for fast local communication. A special driver required for USB communication is provided with the product literature CD.

The relay does not require special communications software. Use any system that emulates a standard terminal system. Establish communication by connecting computers, modems, protocol converters, data concentrators, port switchers, communications processors, and printers.

Connect multiple SEL-351 relays to an SEL communications processor, an SEL real-time automation controller (RTAC), and SEL computing platform, or an SEL synchrophasor vector processor for advanced data collection, protection, and control schemes (see *Figure 17*).

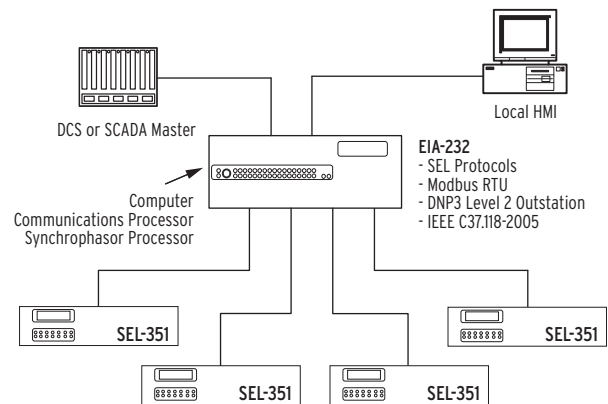

**Figure 17 Typical Serial Communications Architecture**

SEL manufactures a variety of standard cables for connecting this and other relays to a variety of external devices. Consult your SEL representative for more information on cable availability. The SEL-351 can communicate directly with SCADA systems, computers, and RTUs via serial or Ethernet port for local or remote communication (see *Figure 18*).

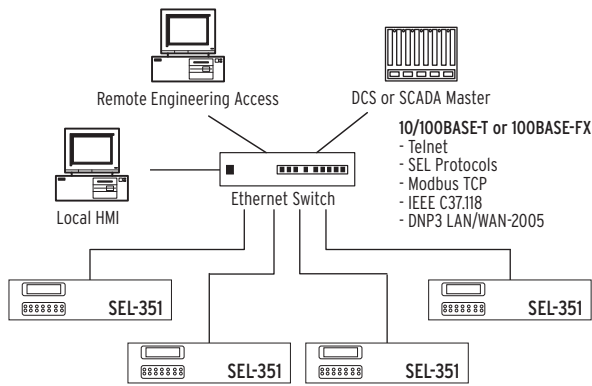

**Figure 18 Typical Ethernet Communications Architecture**

### Dual-Port Ethernet Network Configuration Options

The dual-port Ethernet option increases network reliability and availability by incorporating the relay with external managed or unmanaged switches. Implement a self-healing ring structure with managed switches, or use unmanaged switches in a dual-redundant configuration (see *Figure 19* and *Figure 20*).

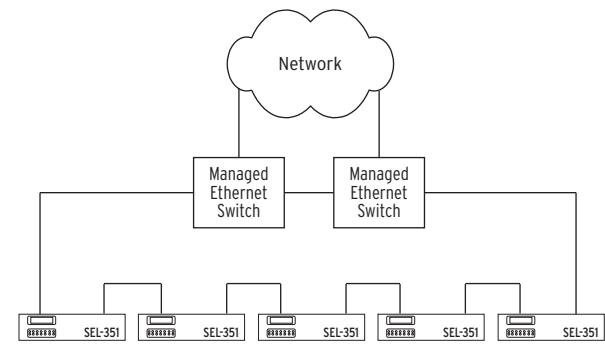

**Figure 19 Self-Healing Ring Using Internal Ethernet Switch**

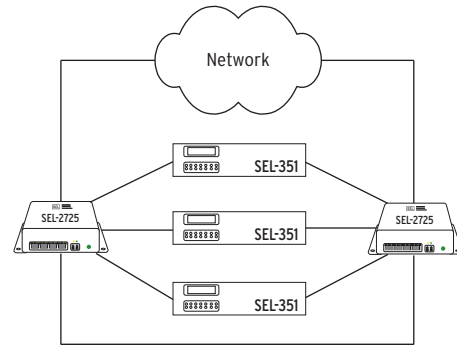

**Figure 20 Failover Network Topology**

*Table 6* lists the communications protocols available on the SEL-351 for protection, monitoring, control, interrogation, setting, and reporting.

**Table 6 Open Communications Protocols**

Type	Description
IEC 61850	Ethernet-based international standard for interoperability between intelligent devices in a substation. Operates remote bits, breaker controls, and I/O. Monitors Relay Word bits and analog quantities. Use MMS file transfer to retrieve event and breaker monitor reports.
Simple ASCII	Plain language commands for human and simple machine communication. Use for metering, setting, self-test status, event reporting, and other functions.
Compressed ASCII	Comma-delimited ASCII data reports. Allows external devices to obtain relay data in an appropriate format for direct import into spreadsheets and database programs. Data are checksum protected.
Extended Fast Meter and Fast Operate	Serial or Telnet binary protocol for machine-to-machine communication. Quickly updates SEL communications processors, RTUs, and other substation devices with metering information, relay element and I/O status, time-tags, open and close commands, and summary event reports. Data are checksum protected. Binary and ASCII protocols operate simultaneously over the same communications lines so binary SCADA metering information is not lost while an engineer or technician is transferring an event report or communicating with the relay using ASCII communication through the same relay communications port.
SEL Distributed Port Switch (LMD) Protocol	Enables multiple SEL devices to share a common communications bus (two-character address setting range is 01–99). Use this protocol for low-cost, port-switching applications.
Fast SER Protocol	Provides serial or Ethernet SER data transfers with original time stamps to an automated data collection system.
Modbus RTU or TCP	Serial or Ethernet-based Modbus with point remapping. Includes access to metering data, protection elements, contact I/O, targets, relay summary events, and settings groups.
DNP3 Serial or LAN/WAN	Serial or Ethernet-based Distributed Network Protocol with point remapping. Includes access to metering data, protection elements, contact I/O, targets, SER, relay summary event reports, and settings groups.
IEEE C37.118-2005	Serial or Ethernet Phasor Measurement Protocol. Streams synchrophasor data to archiving historian for postdisturbance analysis, to visualization software for real-time monitoring, or to synchrophasor data processor for real-time control.

## Control Logic and Integration

SEL-351 control logic improves integration in the following ways:

- ▶ **Replace traditional panel control switches.** As many as 16 local control switch functions (Local Bits LB1–LB16) can be programmed for operation through the CNTRL front-panel pushbutton. Set, clear, or pulse selected Local Bits and program the front-panel operator pushbuttons and LEDs and the Local Bits into your control scheme with SELOGIC control equations. Use the Local Bits to perform functions such as turning ground tripping and auto-reclosing on and off or a breaker trip/close.
- ▶ **Eliminate RTU-to-relay wiring.** Use serial or LAN/WAN communication to control as many as 32 remote control switches (Remote Bits RB1–RB32). Set, clear, or pulse selected Remote Bits over serial port or network communication using ASCII, DNP, or Modbus commands. Program the Remote Bits into your control scheme with SELOGIC control equations. Use Remote Bits for SCADA-type control operations such as trip, close, and turning autoreclose on or off.
- ▶ **Replace traditional latching relays.** Perform traditional latching relay functions, such as “remote control enable”, with 16 internal logic latch control switches (Latch Bits LT1–LT16). Program latch set and latch reset conditions with SELOGIC control equations. Set or reset the nonvolatile Latch Bits using optoisolated inputs, remote control switches, local control switches, or any programmable logic condition. The Latch Bits retain their state when the relay loses power.
- ▶ **Replace traditional indicating panel lights.** Use 16 programmable rotating messages on the front-panel LCD display to define custom text messages (e.g., Breaker Open, Breaker Closed, and real-time analog quantities) that report power system or relay conditions. Use SELOGIC control equations to control which rotating display messages are displayed.
- ▶ **Eliminate external timers.** Provide custom protection or control schemes with 16 general purpose SELOGIC control equation timers. Each timer has

independent time-delay pickup and dropout settings. Program each timer input with any desired element (e.g., time qualify a current element). Assign the timer output to trip logic, transfer trip communication, or other control scheme logic.

- ▶ **Eliminate settings changes.** Selectable setting groups make the SEL-351 ideal for applications requiring frequent setting changes and for adapting the protection to changing system conditions.

The relay stores six setting groups. Select the active setting group by optoisolated input, command, or other programmable conditions. Use these setting groups to cover a wide range of protection and control contingencies.

Changing setting groups switches logic and relay element settings. Program groups for different operating conditions, such as feeder paralleling, station maintenance, seasonal operations, emergency contingencies, loading, source changes, and downstream relay setting changes.

## Fast SER Protocol

SEL Fast Sequential Events Recorder (SER) Protocol provides SER events to an automated data collection system. SEL Fast SER Protocol is available on any serial port. Devices with embedded processing capability can use these messages to enable and accept unsolicited binary SER messages from SEL-351 Relays.

SEL relays and communications processors have two separate data streams that share the same serial port. The normal serial interface consists of ASCII character commands and reports that are intelligible to people using a terminal or terminal emulation package. The binary data streams can interrupt the ASCII data stream to obtain information, and then allow the ASCII data stream to continue. This mechanism allows a single communications channel to be used for ASCII communication (e.g., transmission of a long event report) interleaved with short bursts of binary data to support fast acquisition of metering or SER data.

## Added Capabilities

### MIRRORED BITS<sup>®</sup> Communications

The SEL-patented MIRRORED BITS communications technology provides bidirectional digital communication between any two MIRRORED BITS-capable devices. MIRRORED BITS can operate independently on as many as two EIA-232 serial ports on a single SEL-351-6 or -7 (not available on the SEL-351-5).

This bidirectional digital communication creates eight additional virtual outputs (transmitted MIRRORED BITS) and eight additional virtual inputs (received MIRRORED BITS) for each serial port operating in the MIRRORED BITS mode (see *Figure 21*). Use these MIRRORED BITS to transmit/receive information between upstream relays and downstream recloser control (e.g., SEL-351R) to enhance coordination and achieve faster tripping for downstream faults. MIRRORED BITS technology also

helps reduce total scheme operating time by eliminating the need to assert output contacts to transmit information.

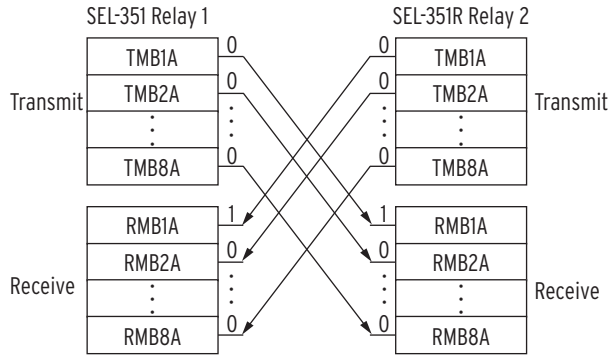

Channel A Relay Word bits shown. Channel B Relay Word bits are TMB1B to TMB8B and RMA1B to RMA8B.

**Figure 21 MIRRORING BITS Transmit and Receive Relay Word Bits (Shown for Channel A)**

## Status and Trip Target LEDs

The SEL-351 includes 16 status and trip target LEDs on the front panel to indicate if the relay is enabled (healthy), follow the reclosing relay state, and to latch in on various trip conditions. This combination of targets is explained in *Table 7* and shown in *Figure 22*.

**Table 7 Description of Front-Panel LEDs**

Target LED	Function
ENABLED	Relay powered properly and self-tests are okay.
TRIP	Trip occurred.
INST	Trip due to instantaneous overcurrent element operation.
COMM	Trip triggered by pilot scheme (e.g., POTT).
SOTF	Switch-onto-fault trip.
50	Inst./def.-time overcurrent trip.
51	Time-overcurrent trip.
81	Underfrequency trip.
RECLOSE STATE	
RESET	Ready for reclose cycle.
CYCLE	Actively in trip/reclose cycle mode.
LOCKOUT	Reclosing relay is in lockout state.
FAULT TYPE	
A, B, C (fixed logic)	Involved phases latch in on trip.
G	Ground involved in fault.
N	Neutral element (channel IN) trip.

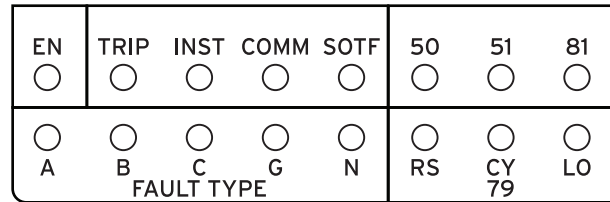

**Figure 22 Status and Trip Target LEDs**

# Wiring Diagram

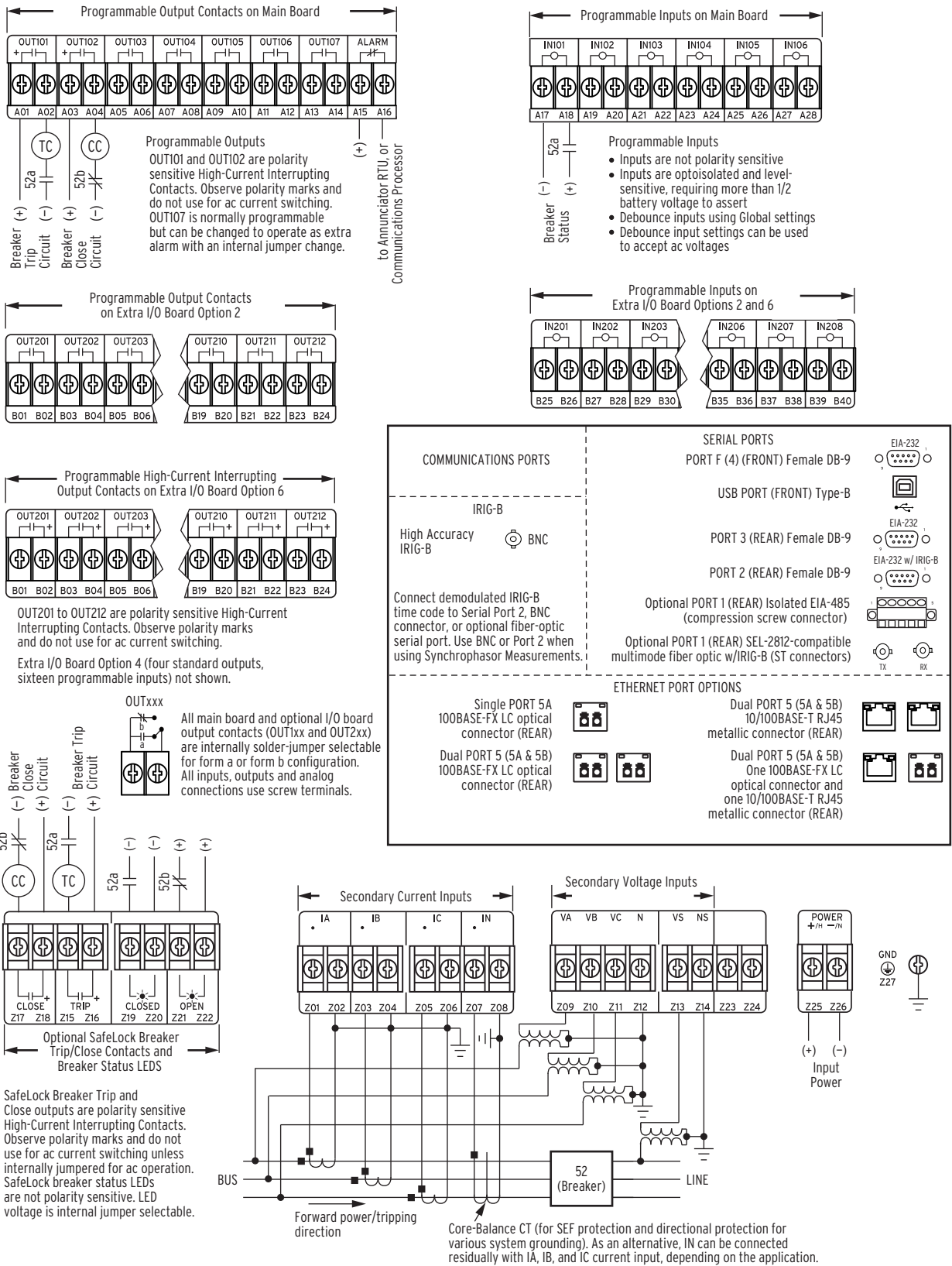
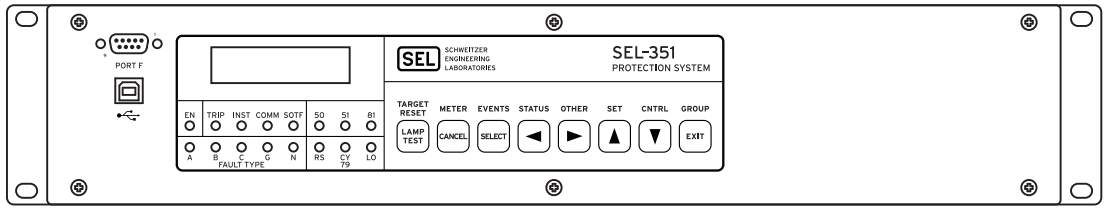

Figure 23 Example SEL-351 Wiring Diagram (Wye-Connected PTs; Synchronism-Check Voltage Input)

# Mechanical Diagrams



Rack Mount With USB Port  
(also available in panel or projection mount)

14354a

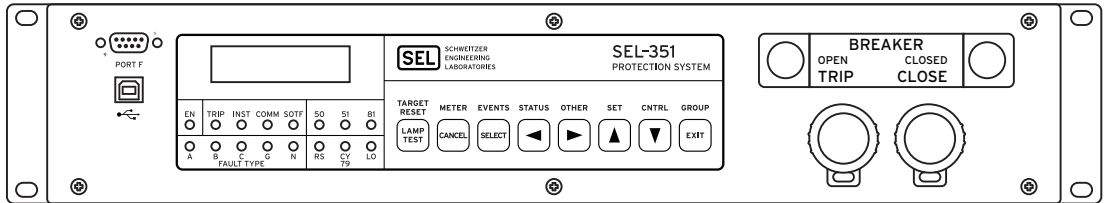

Rack Mount With USB Port and SafeLock Trip/Close Pushbuttons

14287a

**Figure 24 SEL-351 Horizontal Front-Panel Drawings (2U)**

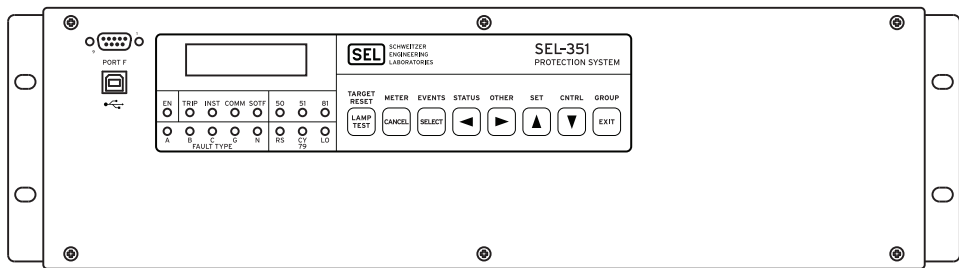

Rack Mount With USB Port  
(also available in panel or projection mount)

14355a

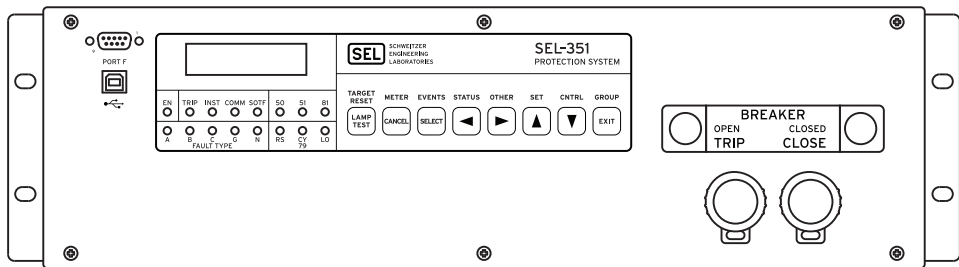

Rack Mount With USB Port and SafeLock Trip/Close Pushbuttons

14289a

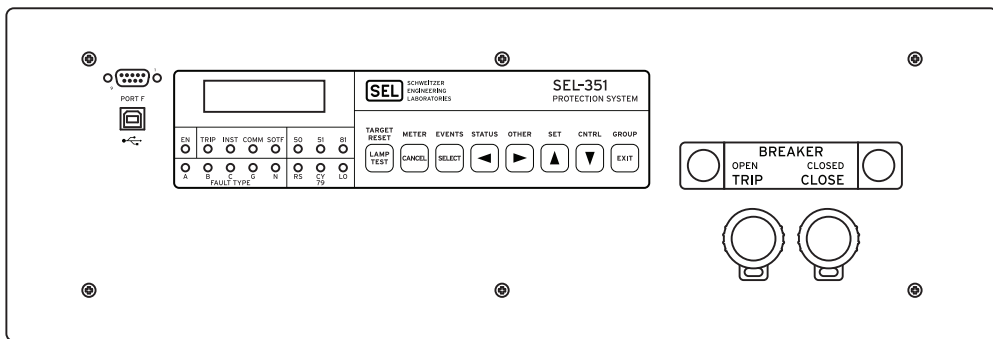

Panel or Projection Mount With USB Port and SafeLock Trip/Close Pushbuttons

14288a

**Figure 25 SEL-351 Horizontal Front-Panel Drawings (3U)**

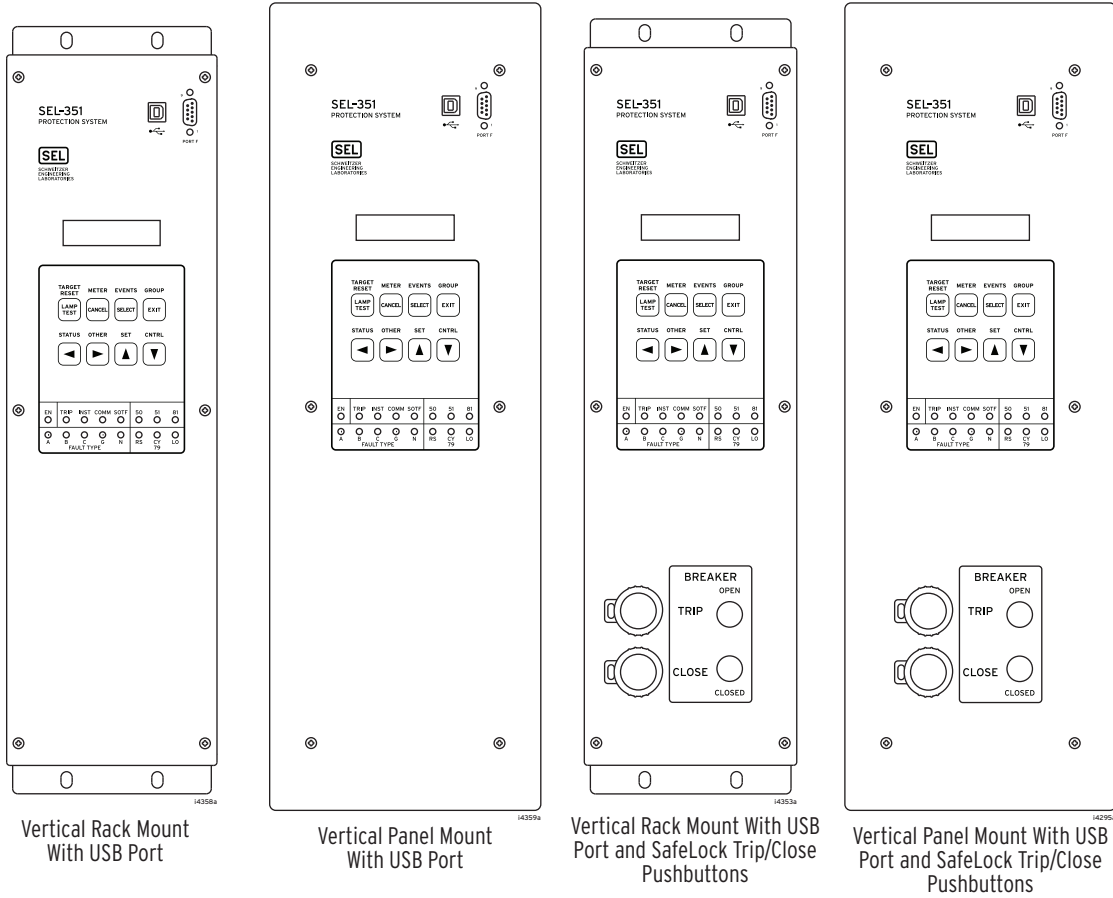
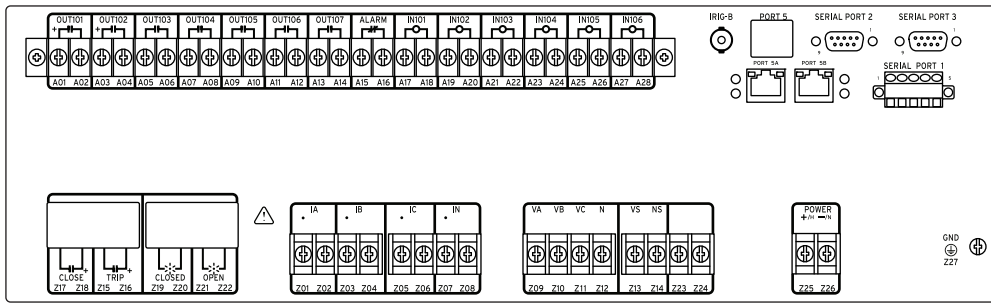
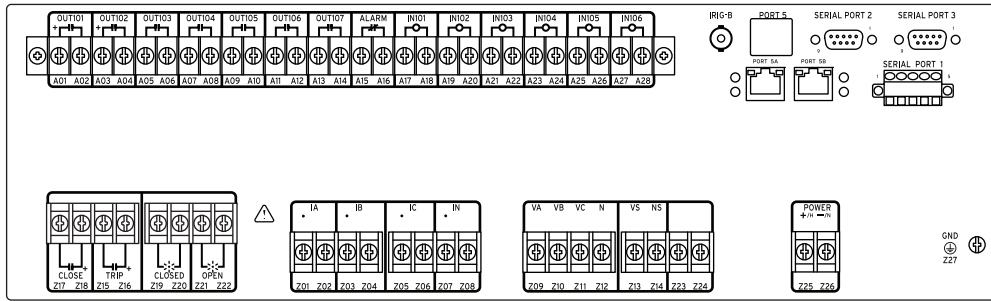

Figure 26 SEL-351 Vertical Front-Panel Drawings (3U)



Standard



With Optional SafeLock Trip/Close Pushbuttons

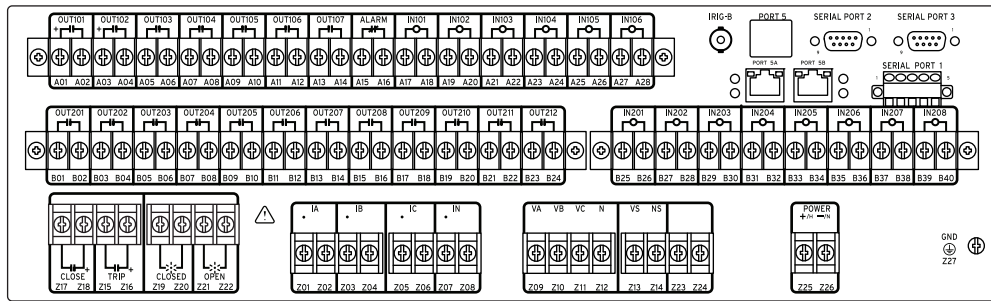

With Optional Extra I/O Board (standard I/O contacts shown, also available with high-current interrupting contacts) and Optional SafeLock Trip/Close Pushbuttons

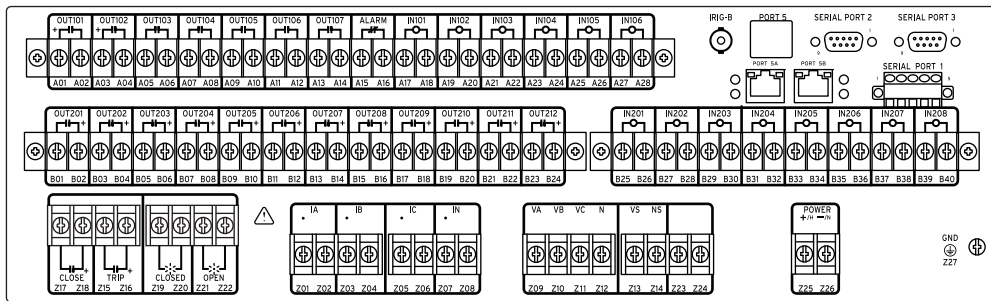

With Optional Extra I/O Board (high-current interrupting contacts shown, also available with standard contacts) and Optional SafeLock Trip/Close Pushbuttons

Vertical mount is identical to horizontal mount configuration rotated by 90 degrees counterclockwise.

**Figure 27 SEL-351 Rear-Panel Drawings (3U) (refer to Figure 29 for communications port configurations)**



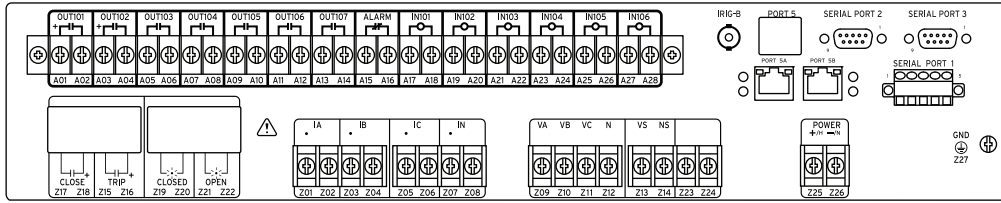

Standard

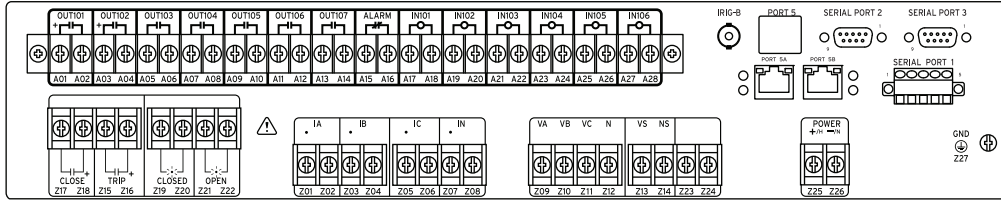

Optional SafeLock Trip/Close Pushbuttons

Vertical mount is identical to horizontal mount configuration rotated by 90 degrees counterclockwise.

**Figure 28 SEL-351 Rear-Panel Drawings (2U) (refer to Figure 29 for communications port configurations)**

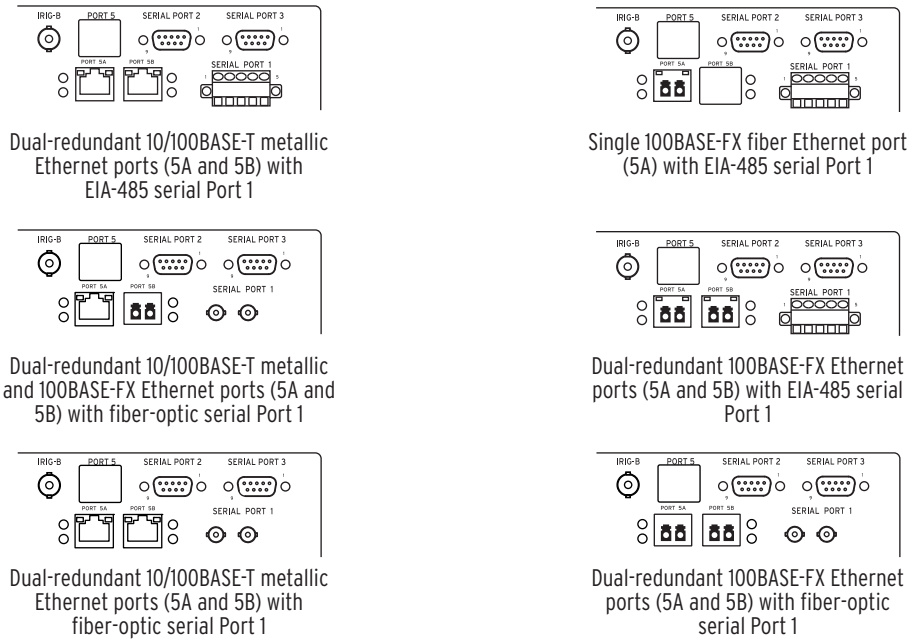

**Figure 29 SEL-351 Rear-Panel Communications Port Configurations**

# Relay Mounting

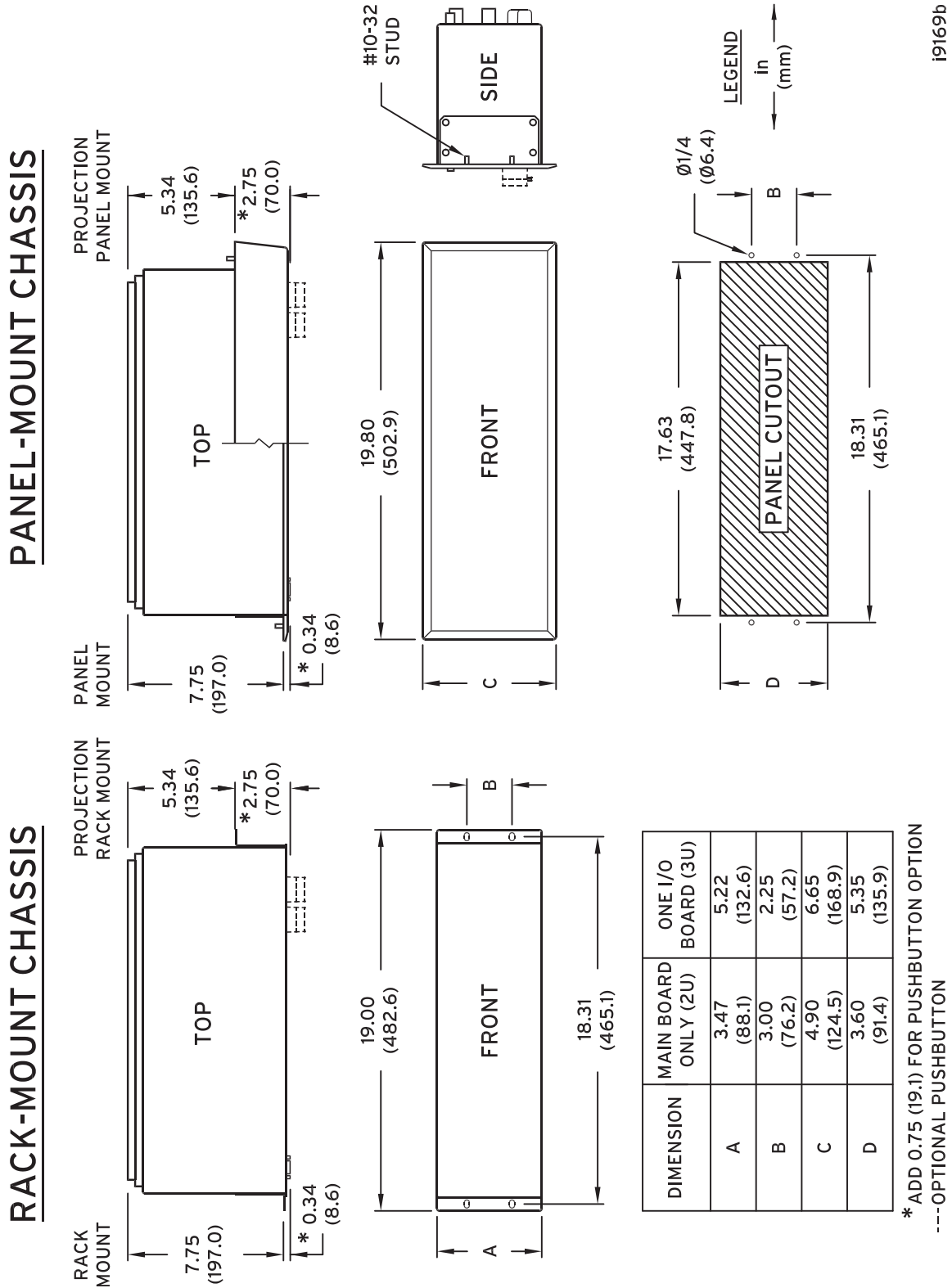

Figure 30 SEL-351 Dimensions and Drill Plan for Rack-Mount and Panel-Mount Models

19169b

# Specifications

**Important:** Do not use the following information to order an SEL-351. Refer to the actual ordering information sheets.

## Compliance

Designed and manufactured under an ISO 9001 certified quality management system  
UL Listed to US and Canadian safety standards (File E212775; NRGU, NRGU7)  
CE Mark  
RCM Mark

## General

### Terminal Connections

**Note:** Terminals or stranded copper wire. Ring terminals are recommended. Minimum temperature rating of 75°C.

#### Tightening Torque

Terminals A01–A28  
Terminals B01–B40  
(if present): 1.1–1.3 Nm (9–12 in-lb)

Terminals Z01–Z27: 1.1–1.3 Nm (9–12 in-lb)

Serial Port 1  
(EIA-485, if present): 0.6–0.8 Nm (5–7 in-lb)

### AC Voltage Inputs

#### Nominal Range

Line to Neutral: 67–120 Vrms

Line to Line  
(open delta): 115–260 Vrms

Continuous: 300 Vrms

Short-Term Overvoltage: 600 Vac for 10 seconds

Burden: 0.03 VA @ 67 V; 0.06 VA @ 120 V;  
0.8 VA @ 300 V

### AC Current Inputs

#### IA, IB, IC, and Neutral Channel IN

5 A Nominal: 15 A continuous, 500 A for 1 s,  
linear to 100 A symmetrical,  
1250 A for 1 cycle

Burden: 0.27 VA @ 5 A, 2.51 VA @ 15 A

1 A Nominal: 3 A continuous, 100 A for 1 s,  
linear to 20 A symmetrical,  
250 A for 1 cycle

Burden: 0.13 VA @ 1 A, 1.31 VA @ 3 A

#### Additional Neutral Channel IN Options

0.2 A Nominal Neutral Channel  
(IN) Current Input: 15 A continuous, 500 A for 1 second, linear  
to 6.4 A symmetrical  
1250 A for 1 cycle

Burden: 0.00009 VA @ 0.2 A, 0.54 VA @ 15 A

0.05 A Nominal Neutral Channel  
(IN) Current Input: 15 A continuous, 500 A for 1 second, linear  
to 6.4 A symmetrical  
1250 A for 1 cycle

Burden: 0.00005 VA @ 0.05 A,  
0.0054 VA @ 1.5 A

**Note:** The 0.2 A nominal neutral channel IN option is used for directional control on low-impedance grounded, Petersen Coil grounded, and ungrounded/ high-impedance grounded systems (see Table 4.3 in the instruction manual). The 0.2 A nominal channel can also provide nondirectional sensitive earth fault (SEF) protection. The 0.05 A nominal neutral channel IN option is a legacy nondirectional SEF option.

## Power Supply

Rated: 125/250 Vdc nominal or 120/230 Vac nominal

Range: 85–350 Vdc or 85–264 Vac

Burden: <25 W

Rated: 48/125 Vdc nominal or 120 Vac nominal

Range: 38–200 Vdc or 85–140 Vac

Burden: <25 W

Rated: 24/48 Vdc nominal

Range: 18–60 Vdc polarity dependent

Burden: <25 W

## Frequency and Rotation

**Note:** 60/50 Hz system frequency and ABC/ACB phase rotation are user-settable.

Frequency Tracking Range: 40–65 Hz (Zero-crossing detection method, preferred source: VA-N terminals. Backup source(s) VB-N or VC-N, depending on PT configuration.)

Maximum Rate of Change: ~20 Hz/s (The relay will not measure faster-changing frequencies, and will revert to nominal frequency if the condition is maintained for more than 0.25 s.)

## Output Contacts

### Standard

#### DC Output Ratings

Make: 30 A

Carry: 6 A continuous carry at 70°C  
4 A continuous carry at 85°C

1 s Rating: 50 A

MOV Protected: 270 Vac/360 Vdc/75 J

Pickup Time: Less than 5 ms

Dropout Time: Less than 5 ms, typical

#### Breaking Capacity (10,000 operations):

24 V	0.75 A	L/R = 40 ms
48 V	0.50 A	L/R = 40 ms
125 V	0.30 A	L/R = 40 ms
250 V	0.20 A	L/R = 40 ms

#### Cyclic Capacity (2.5 cycle/second):

24 V	0.75 A	L/R = 40 ms
48 V	0.50 A	L/R = 40 ms
125 V	0.30 A	L/R = 40 ms
250 V	0.20 A	L/R = 40 ms

**Note:** Make per IEEE C37.90-1989.

**Note:** Breaking and Cyclic Capacity per IEC 60255-0-20:1974.

**Note:** EA certified relays do not have MOV protected standard output contacts.

### AC Output Ratings

Maximum Operational Voltage ( $U_e$ ) Rating: 240 Vac

Insulation Voltage ( $U_i$ ) Rating (excluding EN 61010-1): 300 Vac

Utilization Category: AC-15 (control of electromagnetic loads > 72 VA)

Contact Rating Designation:	B300 (B = 5 A, 300 = rated insulation voltage)
Voltage Protection Across Open Contacts:	270 Vac, 40 J
Rated Operational Current ( $I_o$ ):	3 A @ 120 Vac 1.5 A @ 240 Vac
Conventional Enclosed Thermal Current ( $I_{thc}$ ) Rating:	5 A
Rated Frequency:	50/60 $\pm$ 5 Hz
Electrical Durability Make VA Rating:	3600 VA, $\cos \phi = 0.3$
Electrical Durability Break VA Rating:	360 VA, $\cos \phi = 0.3$

#### High-Current Interruption for OUT101, OUT102, and Extra I/O Board

Make:	30 A
Carry:	6 A continuous carry at 70°C 4 A continuous carry at 85°C
1 s Rating:	50 A
MOV Protection:	330 Vdc/145 J
Pickup Time:	Less than 5 ms
Dropout Time:	Less than 8 ms, typical

#### Breaking Capacity (10,000 operations):

24 V	10 A	L/R = 40 ms
48 V	10 A	L/R = 40 ms
125 V	10 A	L/R = 40 ms
250 V	10 A	L/R = 20 ms

#### Cyclic Capacity (4 cycles in 1 second, followed by 2 minutes idle for thermal dissipation):

24 V	10 A	L/R = 40 ms
48 V	10 A	L/R = 40 ms
125 V	10 A	L/R = 40 ms
250 V	10 A	L/R = 20 ms

**Note:** Make per IEEE C37.90-1989.

**Note:** Do not use high-current interrupting output contacts to switch ac control signals. These outputs are polarity dependent.

**Note:** Breaking and Cyclic Capacity per IEC 60255-0-20:1974.

#### SafeLock® Trip/Close Pushbuttons

##### Resistive DC or AC Load With Arc Suppression Disabled

Make:	30 A
Carry:	6 A continuous carry
1 s Rating:	50 A
MOV Protection:	250 Vac/330 Vdc/130 J

#### Breaking Capacity (10,000 operations):

48 V	0.50 A	L/R = 40 ms
125 V	0.30 A	L/R = 40 ms
250 V	0.20 A	L/R = 40 ms

**Note:** Make per IEEE C37.90-1989.

##### High-Interrupt DC Outputs With Arc Suppression Enabled

Make:	30 A
Carry:	6 A continuous carry
1 s Rating:	50 A
MOV Protection:	330 Vdc/130 J

#### Breaking Capacity (10,000 operations):

48 V	10 A	L/R = 40 ms
125 V	10 A	L/R = 40 ms
250 V	10 A	L/R = 20 ms

**Note:** Make per IEEE C37.90-1989.

#### Breaker Open/Closed LEDs

250 Vdc:	on for 150–300 Vdc;	192–288 Vac
125 Vdc:	on for 80–150 Vdc;	96–144 Vac
48 Vdc:	on for 30–60 Vdc;	
24 Vdc:	on for 15–30 Vdc	

**Note:** With nominal control voltage applied, each LED draws 8 mA (max.). Jumpers may be set to 125 Vdc for 110 Vdc input and set to 250 Vdc for 220 Vdc input.

#### Optoisolated Input Ratings

##### When Used With DC Control Signals

250 Vdc:	on for 200–300 Vdc;	off below 150 Vdc
220 Vdc:	on for 176–264 Vdc;	off below 132 Vdc
125 Vdc:	on for 105–150 Vdc;	off below 75 Vdc
110 Vdc:	on for 88–132 Vdc;	off below 66 Vdc
48 Vdc:	on for 38.4–60 Vdc;	off below 28.8 Vdc
24 Vdc:	on for 15–30 Vdc	

##### When Used With AC Control Signals

250 Vdc:	on for 170.6–300 Vac;	off below 106.0 Vac
220 Vdc:	on for 150.3–264.0 Vac;	off below 93.2 Vac
125 Vdc:	on for 89.6–150.0 Vac;	off below 53.0 Vac
110 Vdc:	on for 75.1–132.0 Vac;	off below 46.6 Vac
48 Vdc:	on for 32.8–60.0 Vac;	off below 20.3 Vac
24 Vdc:	on for 12.8–30.0 Vac	

**Note:** AC mode is selectable for each input via Global settings IN101D–IN106D and IN201D–IN216D. AC input recognition delay from time of switching: 0.75 cycles maximum pickup, 1.25 cycles maximum dropout.

**Note:** All optoisolated inputs draw less than 10 mA of current at nominal voltage or ac rms equivalent.

#### Time-Code Inputs

Relay accepts demodulated IRIG-B time-code input at Port 2, on the rear-panel BNC output, or through the optional SEL-2812-compatible fiber-optic serial port.

Port 2, Pin 4 Input Current:	1.8 mA typical at 4.5 V (2.5 k $\Omega$ resistive)
BNC Input Current:	4 mA typical at 4.5 V (750 $\Omega$ resistive when input voltage is greater than 2 V)

#### Synchronization Accuracy

Internal Clock:	$\pm$ 1 $\mu$ s
Synchphasor Reports (e.g., MET PM, EVE P, CEV P):	$\pm$ 10 $\mu$ s
All Other Reports:	$\pm$ 5 ms

#### Simple Network Time Protocol (SNTP) Accuracy

Internal Clock:	$\pm$ 5 ms
-----------------	------------

#### Unsynchronized Clock Drift

Relay Powered:	2 minutes per year typical
----------------	----------------------------

#### Communications Ports

EIA-232:	1 front, 2 rear
EIA-485:	1 rear with 2100 Vdc of isolation, optional
Fiber-Optic Serial Port:	SEL-2812-compatible port, optional
Wavelength:	820 nm
Optical Connector Type:	ST
Fiber Type:	Multimode
Typical TX Power:	–16 dBm
RX Min. Sensitivity:	–24 dBm
Fiber Size:	62.5/125 $\mu$ m
Per Port Data Rate Selections:	300, 1200, 2400, 4800, 9600, 19200, 38400, 57600

USB:	1 front (Type-B connector, CDC class device)
Ethernet:	2 standard 10/100BASE-T rear ports (RJ45 connector) 1 or 2 100BASE-FX rear ports optional (LC connectors) Internal Ethernet switch included with second Ethernet port.

## Dimensions

Refer to *Figure 30*.

## Weight

11 lb (5.0 kg)—2U rack unit height relay
15 lb (6.8 kg)—3U rack unit height relay

## Operating Temperature

–40° to +185°F (–40° to +85°C)  
(LCD contrast impaired for temperatures below –20°C.)  
**Note:** Temperature range is not applicable to UL-compliant installations.

## Type Tests

### Electromagnetic Compatibility Emissions

Emissions:	IEC 60255-25:2000 Class A
------------	---------------------------

### Electromagnetic Compatibility Immunity

Conducted RF Immunity:	IEC 60255-22-6:2001 Severity Level: 10 Vrms IEC 61000-4-6:2008 Severity Level: 10 Vrms
Digital Radio Telephone RF Immunity:	ENV 50204:1995 Severity Level: 10 V/m at 900 MHz and 1.89 GHz
Electrostatic Discharge Immunity:	IEC 60255-22-2:2008 Severity Level 2, 4, 6, 8 kV contact, 2, 4, 8, 15 kV air IEC 61000-4-2:2008 Severity Level 2, 4, 6, 8 kV contact, 2, 4, 8, 15 kV air IEEE C37.90.3-2001 Severity Level 2, 4, and 8 kV contact, 4, 8, and 15 kV air
Fast Transient/Burst Immunity:	IEC 60255-22-4:2008 Severity Level: Class A 4 kV at 5 kHz 2 kV at 5 kHz on communications ports IEC 61000-4-4:2004 + CRGD:2006 Severity Level: 4 kV, 5 kHz
Power Supply Immunity:	IEC 60255-11:2008 IEC 61000-4-11:2004 IEC 61000-4-29:2000
Radiated Radio Frequency Immunity:	IEC 60255-22-3:2007 Severity Level: 10 V/m IEC 61000-4-3:2010 Severity Level: 10 V/m IEEE C37.90.2-2004 Severity Level: 35 V/m
Surge Withstand Capability Immunity:	IEC 60255-22-1:2007 Severity Level: 2.5 kV peak common mode, 1.0 kV peak differential mode IEEE C37.90.1-2002 Severity Level: 2.5 kV oscillatory; 4.0 kV fast transient waveform

## Environmental

Cold:	IEC 60068-2-1:2007 Severity Level: 16 hours at –40°C
Damp Heat, Cyclic:	IEC 60068-2-30:2005 Severity Level: 25°C to 55°C, 6 cycles, Relative Humidity: 95%

Dry Heat:	IEC 60068-2-2:2007 Severity Level: 16 hours at +85°C
Vibration:	IEC 60255-21-1:1988 Severity Level: Class 1 Endurance, Class 2 Response IEC 60255-21-2:1988 Severity Level: Class 1—Shock Withstand, Bump, and Class 2—Shock Response IEC 60255-21-3:1993 Severity Level: Class 2 (Quake Response)

## Safety

Dielectric:	IEC 60255-5:2000 Severity Level: 2500 Vac on contact inputs, contact outputs, and analog inputs. 3100 Vdc on power supply. Type Tested for one minute. IEEE C37.90-2005 Severity Level: 2500 Vac on contact inputs, contact outputs, and analog inputs. 3100 Vdc on power supply. Type Tested for one minute.
Impulse:	IEC 60255-5:2000 Severity Level: 0.5 Joule, 5 kV IEEE C37.90-2005 Severity Level: 0.5 Joule, 5 kV
IP Code:	IEC 60529:2001 + CRDG:2003 Severity Level: IP30
Product Safety:	C22.2 No. 14 – 95 Canadian Standards Association, Industrial control equipment, industrial products UL 508 Underwriters Laboratories Inc., Standard for safety: Industrial control equipment

## Processing Specifications and Oscilloscopy

### AC Voltage and Current Inputs

128 samples per power system cycle, 3 dB low-pass filter cut-off frequency of 3 kHz

### Digital Filtering

Digital low-pass filter then decimate to 32 samples per cycle followed by one-cycle cosine filter.  
Net filtering (analog plus digital) rejects dc and all harmonics greater than the fundamental.

### Protection and Control Processing

4 times per power system cycle

### Oscilloscopy

Length:	15, 30, or 60 cycles
Total Storage:	11 seconds of analog and binary
Sampling Rate:	128 samples per cycle unfiltered 32 and 16 samples per cycle unfiltered and filtered 4 samples per cycle filtered
Trigger:	Programmable with Boolean expression
Format:	ASCII and Compressed ASCII Binary COMTRADE (128 samples per cycle unfiltered)
Time-Stamp Resolution:	1 $\mu$ s when high-accuracy time source is connected ( <b>EVE P</b> or <b>CEV P</b> commands). 1 ms otherwise.
Time-Stamp Accuracy:	See <i>Time-Code Inputs</i> on page 28.

### Sequential Events Recorder

Time-Stamp Resolution:	1 ms
Time-Stamp Accuracy (with respect to time source):	±5 ms

### Relay Element Pickup Ranges and Accuracies

Accuracy of cycle-based timers is specified for steady-state frequency.

#### Instantaneous/Definite-Time Overcurrent Elements

Pickup Range:	0.25–100.00 A, 0.01 A steps (5 A nominal) 1.00–170.00 A, 0.01 A steps (5 A nominal—for phase-to-phase elements) 0.050–100.000 A, 0.010 A steps (5 A nominal—for residual-ground elements) 0.05–20.00 A, 0.01 A steps (1 A nominal) 0.20–34.00 A, 0.01 A steps (1 A nominal—for phase-to-phase elements) 0.010–20.000 A, 0.002 A steps (1 A nominal—for residual-ground elements) 0.005–2.500 A, 0.001 A steps (0.2 A nominal neutral channel (IN) current input) 0.005–1.500 A, 0.001 A steps (0.05 A nominal neutral channel (IN) current input)
Steady-State Pickup Accuracy:	±0.05 A and ±3% of setting (5 A nominal) ±0.01 A and ±3% of setting (1 A nominal) ±0.001 A and ±3% of setting (0.2 A nominal neutral channel (IN) current input) ±0.001 A and ±5% of setting (0.05 A nominal neutral channel (IN) current input)
Transient Overreach:	±5% of pickup
Time Delay:	0.00–16,000.00 cycles, 0.25 cycle steps
Timer Accuracy:	±0.25 cycle and ±0.1% of setting

**Note:** See pickup and reset time curves in *Figure 3.5* and *Figure 3.6* in the instruction manual.

#### Breaker Failure Current Detectors and Logic

Pickup Range:	0.5–100.00 A, 0.01 A steps (5 A nominal) 0.1–20.00 A, 0.01 A steps (1 A nominal)
Steady-State Pickup Accuracy:	±0.05 A and ±3% of setting (5 A nominal) ±0.01 A and ±3% of setting (1 A nominal)
Transient Overreach:	±5% of pickup
Reset Time:	≤1 cycle
Pickup Time:	≤1 cycle for currents greater than 2 multiples of pickup
Time Delay:	0.00–16,000.00 cycles, 0.25 cycle steps
Timer Accuracy:	±0.25 cycle and ±0.1% of setting

### Time-Overcurrent Elements

Pickup Range:	0.25–16.00 A, 0.01 A steps (5 A nominal) 0.10–16.00 A, 0.01 A steps (5 A nominal—for residual-ground elements) 0.05–3.20 A, 0.01 A steps (1 A nominal) 0.02–3.20 A, 0.01 A steps (1 A nominal—for residual-ground elements) 0.005–0.640 A, 0.001 A steps (0.2 A nominal neutral channel (IN) current input) 0.005–0.160 A, 0.001 A steps (0.05 A nominal neutral channel (IN) current input)
Steady-State Pickup Accuracy:	±0.05 A and ±3% of setting (5 A nominal) ±0.01 A and ±3% of setting (1 A nominal) ±0.005 A and ±3% of setting (0.2 A nominal neutral channel (IN) current input) ±0.001 A and ±5% of setting (0.05 A nominal neutral channel (IN) current input)
Time-Dial Range:	0.50–15.00, 0.01 steps (US) 0.05–1.00, 0.01 steps (IEC) 0.10–2.00, in 0.01 steps (recloser curves)
Curve Timing Accuracy:	±1.50 cycles and ±4% of curve time for current between 2 and 30 multiples of pickup ±1.50 cycles and ±4% of curve time for current less than 1 multiple of pickup ±3.50 cycles and ±4% of curve time for current between 2 and 30 multiples of pickup for 0.05 A nominal neutral channel (IN) current input ±3.50 cycles and ±4% of curve time for current less than 1 multiple of pickup for 0.05 A nominal neutral channel (IN) current input

#### Second-Harmonic Blocking Elements

Pickup Range:	5–100% of fundamental, 1% steps
Steady-State Pickup Accuracy:	2.5 percentage points
Pickup/Dropout Time:	<1.25 cycles
Time Delay:	0.00–16,000.00 cycles, 0.25 cycle steps
Timer Accuracy:	±0.25 cycle and ±0.1% of setting

#### Under- and Overvoltage Elements

Pickup Ranges	
Wye-Connected (Global setting PTCNN = WYE):	0.00–200.00 V, 0.01 V steps (negative-sequence element) 0.00–300.00 V, 0.01 V or 0.02 V steps (various elements) 0.00–520.00 V, 0.02 V steps (phase-to-phase elements)
Open-Delta Connected (when available, by Global setting PTCNN = DELTA):	0.00–120.00 V, 0.01 V steps (negative-sequence elements) 0.00–170.00 V, 0.01 V steps (positive-sequence element) 0.00–300.00 V, 0.01 V steps (various elements)

Steady-State Pickup Accuracy:	±0.5 V plus ±1% for 12.5–300.00 V (phase and synchronizing elements) ±0.5 V plus ±2% for 12.5–300.00 V (negative-, positive-, and zero-sequence elements, phase-to-phase elements)
Transient Overreach:	±5% of pickup

**Synchronism-Check Elements**

Slip Frequency Pickup Range:	0.005–1.000 Hz, 0.001 Hz steps
Slip Frequency Pickup Accuracy:	±0.003 Hz
Phase Angle Range:	0–80°, 1° steps
Phase Angle Accuracy:	±4° when  slip frequency  ≤ 0.4 Hz ±10° when 0.4 Hz <  slip frequency  < 1.0 Hz

**Under- and Overfrequency Elements**

Pickup Range:	40.10–65.00 Hz, 0.01 Hz steps	
Steady-State <i>plus</i> Transient Overshoot:	±0.01 Hz	
Pickup/Dropout Time:	Maximum instantaneous element response time to a step change in frequency (dF)	
dF ≤ 0.3 Hz	NFREQ = 50 Hz	NFREQ = 60 Hz
81DnP-Initial Frequency  ≤ 0.5 kDf	45 ms	40 ms
81DnP-Initial Frequency  > 0.5 kDf	60 ms	50 ms
dF > 0.3 Hz	NFREQ = 50 Hz	NFREQ = 60 Hz
81DnP-Initial Frequency  ≤ 0.5 kDf	75 ms	60 ms
81DnP-Initial Frequency  > 0.5 kDf	85 ms	70 ms
Time Delay:	2.00–16,000.00 cycles, 0.25-cycle steps	
Timer Accuracy:	±0.25 cycle and ±0.1% of setting	
Undervoltage Frequency Element Block Range:	25.00–300.00 V <sub>LN</sub> (wye) or V <sub>LL</sub> (open delta)	

**Rate-of-Change-of-Frequency Element**

Pickup Range:	0.10–15.00 Hz/sec, 0.01 Hz/sec steps
Dropout:	95% of pickup
Pickup Accuracy:	±100 mHz/s and ±3.33% of pickup
Pickup/Dropout Time:	See <i>Equation 3.1</i> in the instruction manual.
Pickup Time Delay:	0.10–60.00 seconds, 0.01 second steps
Dropout Time Delay:	0.00–60.00 seconds, 0.01 second steps
Timer Accuracy:	±6 ms and ±0.1% of setting

**Timers**

Pickup Ranges:	0.00–999,999.00 cycles, 0.25-cycle steps (reclosing relay and some programmable timers) 0.00–16,000.00 cycles, 0.25-cycle steps (some programmable and other various timers)
Pickup and Dropout Accuracy for all Timers:	±0.25 cycle and ±0.1% of setting

**Substation Battery Voltage Monitor**

Pickup Range:	20–300 Vdc, 1 Vdc steps
Pickup Accuracy:	±2% of setting ±2 Vdc

**Fundamental Metering Accuracy**

Accuracies are specified at 20°C, at nominal system frequency, and voltages 67–250 V unless noted otherwise.

V <sub>A</sub> , V <sub>B</sub> , V <sub>C</sub> :	±0.2% (67.0–250 V; wye-connected) ±0.4% typical (250–300 V; wye-connected)
V <sub>AB</sub> , V <sub>BC</sub> , V <sub>CA</sub> :	±0.4% (67.0–250 V; delta-connected) ±0.8% typical (250–300 V; delta-connected)
V <sub>S</sub> :	±0.2% (67.0–250 V) ±0.4% typical (250–300 V)
3V <sub>0</sub> , V <sub>1</sub> , V <sub>2</sub> (3V <sub>0</sub> not available with delta-connected inputs):	±0.6% (67.0–250 V) ±1.2% typical (250–300 V)
I <sub>A</sub> , I <sub>B</sub> , I <sub>C</sub> :	±4 mA and ±0.1% (1.0–100 A) (5 A nominal) ±6 mA and ±0.1% (0.25–1.0 A) (5 A nominal) ±1 mA and ±0.1% (0.2–20 A) (1 A nominal) ±2 mA and ±0.1% (0.05–0.2 A) (1 A nominal) Temperature coefficient: [(0.0002%)/(°C) <sup>2</sup> ] • (°C – 20°C) <sup>2</sup>
I <sub>N</sub> :	±4 mA and ±0.1% (1.0–100 A) (5 A nominal) ±6 mA and ±0.1% (0.25–1.0 A) (5 A nominal) ±1 mA and ±0.1% (0.2–20 A) (1 A nominal) ±2 mA and ±0.1% (0.05–0.2 A) (1 A nominal) ±1.6 mA and ±0.1% (0.005–4.5 A) (0.2 A or 0.05 A nominal channel IN current input)
I <sub>1</sub> , 3I <sub>0</sub> , 3I <sub>2</sub> :	±0.05 A and ±3% (0.5–100 A) (5 A nominal) ±0.01 A and ±3% (0.1–20 A) (1 A nominal)

**Phase Angle Accuracy**

I <sub>A</sub> , I <sub>B</sub> , I <sub>C</sub> :	±0.5° (1.0–100 A) (5 A nominal) ±3° (0.25–1.0 A) (5 A nominal) ±0.5° (0.2–20 A) (1 A nominal) ±5° (0.05–0.2 A) (1 A nominal)
V <sub>A</sub> , V <sub>B</sub> , V <sub>C</sub> , V <sub>S</sub> (wye-connected voltages):	±0.5°
V <sub>AB</sub> , V <sub>BC</sub> , V <sub>CA</sub> , V <sub>S</sub> (delta-connected voltages):	±1.0°

MW/MVAR (A, B, C, and three-phase; wye-connected voltages)	
MW/MVAR (three-phase; open-delta connected voltages; balanced conditions)	
Accuracy (MW/MVAR)	at load angle
for phase current ≥ 0.2 • I <sub>NOM</sub> :	
0.35% / –	0° or 180° (unity power factor)
0.40% / 6.00%	±8° or ±172°
0.75% / 1.50%	±30° or ±150°
1.00% / 1.00%	±45° or ±135°
1.50% / 0.75%	±60° or ±120°
6.00% / 0.40%	±82° or ±98°
– / 0.35%	±90° (power factor = 0)

## Energy Meter

Accumulators:	Separate IN and OUT accumulators updated twice per second, transferred to nonvolatile storage once per day.
ASCII Report Resolution:	0.01 MWh
Accuracy:	The accuracy of the energy meter depends on applied current and power factor as shown in the power metering accuracy table above. The additional error introduced by accumulating power to yield energy is negligible when power changes slowly compared to the processing rate of twice per second.

## Synchrophasor Accuracy

### Maximum Data Rate in Messages per Second

IEEE C37.118 Protocol:	60 (nominal 60 Hz system) 50 (nominal 50 Hz system)
SEL Fast Message Protocol:	1
IEEE C37.118-2005 Accuracy:	Level 1 at maximum message rate when phasor has the same frequency as phase A voltage, frequency-based phasor compensation is enabled (PHCOMP = Y), and the narrow-bandwidth filter is selected (PMAPP = N). Out-of-band interfering frequency (Fs) test, $10 \text{ Hz} \leq F_s \leq (2 \cdot \text{NFREQ})$ .
Current Range:	$(0.1-2) \cdot I_{\text{NOM}}$ ( $I_{\text{NOM}} = 1 \text{ A}$ or $5 \text{ A}$ )
Frequency Range:	$\pm 5 \text{ Hz}$ of nominal (50 or 60 Hz)
Voltage Range:	30 V–250 V
Phase Angle Range:	$-179.99^\circ$ to $180^\circ$

## Harmonic Metering Accuracy

### Voltages $V_A$ , $V_B$ , $V_C$ , $V_S$ (Wye or Single-Phase); $V_{AB}$ , $V_{BC}$ , $V_S$ (Delta)

Accuracies valid for THD < 100%, 30 V < fundamental < 200 V sec, 50 Hz or 60 Hz	
RMS and Fundamental Magnitude:	$\pm 5\%$
THD Percentage:	$\pm 5$ percentage points
02 Through 16	
Harmonic Percentage:	$\pm 5$ percentage points

### Currents $I_A$ , $I_B$ , $I_C$ , $I_N$

Accuracies valid for THD < 100%, fundamental voltage < 200 V, 50 Hz or 60 Hz	
5 A Nominal:	0.25 A < fundamental current < 5 A sec
1 A Nominal:	0.05 A < fundamental current < 1 A sec
0.2 A and 0.05 A Nominal (IN channel only):	0.01 A < fundamental current < 1 A sec

RMS and Fundamental Magnitude:	$\pm 5\%$
THD Percentage:	$\pm 5$ percentage points
02 Through 16	
Harmonic Percentage:	$\pm 5$ percentage points

## Power Element Accuracy

### Single-Phase Power Elements

Pickup Setting 0.33–2 VA (5 A nominal), 0.07–0.4 VA (1 A nominal):	$\pm 0.05 \text{ A} \cdot (\text{L-N voltage secondary})$ and $\pm 10\%$ of setting at unity power factor for power elements and zero power factor for reactive power element (5 A nominal) $\pm 0.01 \text{ A} \cdot (\text{L-N voltage secondary})$ and $\pm 10\%$ of setting at unity power factor for power elements and zero power factor for reactive power element (1 A nominal)
Pickup Setting 2–13000 VA (5 A nominal), 0.4–2600 VA (1 A nominal):	$\pm 0.025 \text{ A} \cdot (\text{L-N voltage secondary})$ and $\pm 5\%$ of setting at unity power factor (5 A nominal) $\pm 0.005 \text{ A} \cdot (\text{L-N voltage secondary})$ and $\pm 5\%$ of setting at unity power factor (1 A nominal)

### Three-Phase Power Elements

Pickup Setting 1–6 VA (5 A nominal), 0.2–1 VA (1 A nominal):	$\pm 0.05 \text{ A} \cdot (\text{L-L voltage secondary})$ and $\pm 10\%$ of setting at unity power factor for power elements and zero power factor for reactive power element (5 A nominal) $\pm 0.01 \text{ A} \cdot (\text{L-L voltage secondary})$ and $\pm 10\%$ of setting at unity power factor for power elements and zero power factor for reactive power element (1 A nominal)
Pickup Setting 6–39000 VA (5 A nominal), 1–7800 VA (1 A nominal):	$\pm 0.025 \text{ A} \cdot (\text{L-L voltage secondary})$ and $\pm 5\%$ of setting at unity power factor for power elements and zero power factor for reactive power element (5 A nominal) $\pm 0.005 \text{ A} \cdot (\text{L-L voltage secondary})$ and $\pm 5\%$ of setting at unity power factor for power elements and zero power factor for reactive power element (1 A nominal)

The quoted three-phase power element accuracy specifications are applicable as follows:

- Wye-connected voltages (PTCONN = WYE): any condition
- Open-delta connected voltages (PTCONN = DELTA), with properly configured broken-delta 3V0 connection (VSCONN = 3V0): any condition
- Open-delta connected voltages, without broken-delta 3V0 connection (VSCONN = VS): balanced conditions only

© 2009–2017 by Schweitzer Engineering Laboratories, Inc. All rights reserved.

All brand or product names appearing in this document are the trademark or registered trademark of their respective holders. No SEL trademarks may be used without written permission. SEL products appearing in this document may be covered by U.S. and Foreign patents.

Schweitzer Engineering Laboratories, Inc. reserves all rights and benefits afforded under federal and international copyright and patent laws in its products, including without limitation software, firmware, and documentation.

The information in this document is provided for informational use only and is subject to change without notice. Schweitzer Engineering Laboratories, Inc. has approved only the English language document.

This product is covered by the standard SEL 10-year warranty. For warranty details, visit selinc.com or contact your customer service representative.

## SCHWEITZER ENGINEERING LABORATORIES, INC.

2350 NE Hopkins Court • Pullman, WA 99163-5603 U.S.A.

Tel: +1.509.332.1890 • Fax: +1.509.332.7990

selinc.com • info@selinc.com

