



SEL-311C-1 Transmission Protection System

Powerful Solutions for Transmission Line Protection



Major Features and Benefits

The SEL-311C Transmission Protection System is an advanced, full-featured, three-pole trip, three-pole reclose relay for transmission protection applications.

Protection Functions

- Four zones of mho phase-distance elements, and four zones of mho and quadrilateral ground-distance elements provide comprehensive distance protection for transmission lines.
- Settings allow three-phase wye or three-phase delta voltage inputs.
- Coupling capacitor voltage transformer (CCVT) transient overreach logic enhances security of Zone 1 elements.
- Out-of-step logic blocks distance elements for stable power swings or trips for unstable power swings.
- Additional resistance blinders unblock distance elements if a three-phase fault occurs during a swing.
- Negative-sequence directional overcurrent elements unblock distance elements if an unbalanced fault occurs during a power swing.
- Load-encroachment logic distinguishes between heavy load and three-phase faults.
- Built-in communications-assisted trip scheme logic permits fast trip times, reducing fault duration that adversely impacts system stability.
- Phase, negative-sequence, and residual-ground overcurrent elements with directional control optimize network protection for lines and equipment.
- Best Choice Ground Directional Element[®] logic optimizes directional element performance and requires no directional settings.
- High-speed breaker failure element and native breaker failure logic enhance breaker failure detection.

- Implement load shedding and other control schemes with over/underfrequency and over/undervoltage elements and powerful SELOGIC[®] control equations.
- SELOGIC control equations permit custom programming for traditional and unique protection, automation, and control functions.

Automatic Reclosing and Synchronism Check

- Program as many as four shots of automatic reclosing.
- Supervise manual or automatic reclosing with synchronism check and voltage condition logic.

Synchrophasors

- Improve operator awareness of system conditions with standard IEEE C37.118-2005 Level 1 synchrophasors at as many as 60 messages per second.
- Synchronize 128 sample-per-cycle oscillography and event reports to the microsecond to reconstruct complex disturbances. Synchronize meter reports to verify proper phasing.
- Use the “MRI of the power system” to replace state estimation with state measurement.

Monitoring

- Improve maintenance scheduling using circuit breaker contact wear monitor and substation battery voltage monitors.
- Use alarm elements to inhibit reclosing and provide local and remote alarm indication.
- Analyze oscillographic and Sequential Events Recorder (SER) reports for rapid commissioning, testing, and post-fault diagnostics.
- Use unsolicited SER protocol to allow station-wide collection of binary SER messages with original time stamp for easy chronological analysis.
- Synchronize all reports with IRIG-B on the standard rear-panel BNC or on serial Port 2, from Simple Network Time Protocol (SNTP) on the standard or optional Ethernet connections, or via DNP serial or Ethernet protocols. Connect all possible time sources and the relay automatically selects the best.

Fault Locator

- Efficiently dispatch line crews to quickly isolate line problems and restore service faster.
- Ensure proper distance element operation with fault resistance calculations for phase and ground faults.

Operator Interface and Controls

- Standard target LEDs annunciate trip and status indication and fault type.
- Ten optional programmable operator pushbuttons and indicating LEDs with configurable labels eliminate expensive panel-mounted control switches, lights, and associated wiring.
- Optional programmable target LEDs increase the flexibility of annunciating trip and status indication.
- Two-line rotating LCD display provides added operator information with programmable display points.
- Optional SafeLock[®] trip/close pushbuttons with high-visibility breaker status LEDs eliminate expensive breaker control switches and position indicating lights. The breaker status LED clusters are bright and easy to see from all viewing angles.

Communications Protocols

- Optional IEC 61850 MMS and GOOSE. As many as seven MMS sessions, guaranteed GOOSE performance with 24 subscriptions and eight publications.
- Standard Modbus[®] with label-based map settings (serial and Ethernet—as many as three sessions).
- Standard DNP3 Level 2 with label-based map settings (serial and Ethernet—as many as six sessions).
- IEEE C37.118-2005 synchrophasor protocol (serial and Ethernet).
- ASCII, SEL Fast Meter, SEL Fast Message, SEL Unsolicited SER, SEL Fast Operate, and SEL Distributed Port Switch (LMD) serial protocols are all standard.
- Standard Telnet and integrated web server on Ethernet.
- Standard dual-channel MIRRORRED BITS[®] communications.
- Parallel redundancy protocol (when supported by hardware).

Communications Hardware

Two 10/100BASE-T Ethernet ports with RJ45 connector included.

- One or two 10/100BASE-FX Ethernet ports with LC multimode fiber-optic connectors optional.
- One 10/100BASE-T Ethernet port and one 10/100BASE-FX Ethernet port with LC multimode fiber-optic connectors optional.
- Front-panel high-speed USB Type-B port included.
- Front-panel EIA-232 DB-9 serial port included.
- Two rear-panel EIA-232 DB-9 ports included.
- One optional rear-panel EIA-485 port with five-position compression terminal block.
- One optional SEL-2812-compatible fiber-optic serial port.

Other Features and Options

- Nominal 1 A or 5 A current inputs.
- Available 750 KB of on-board storage space for ACSELERATOR QuickSet settings file, ACSELERATOR QuickSet design template, or anything else you choose.
- Expanded I/O is available in the 3U chassis. Order any one of the following I/O options:
 - Option X: No extra I/O board
 - Option 2: Additional 8 Inputs and 12 Standard Outputs
 - Option 4: Additional 16 Inputs and 4 Standard Outputs
 - Option 5: Additional 8 Inputs and 8 High-Speed, High Interrupting Current Outputs
 - Option 6: Additional 8 Inputs and 12 High Interrupting Current Outputs

Functional Overview

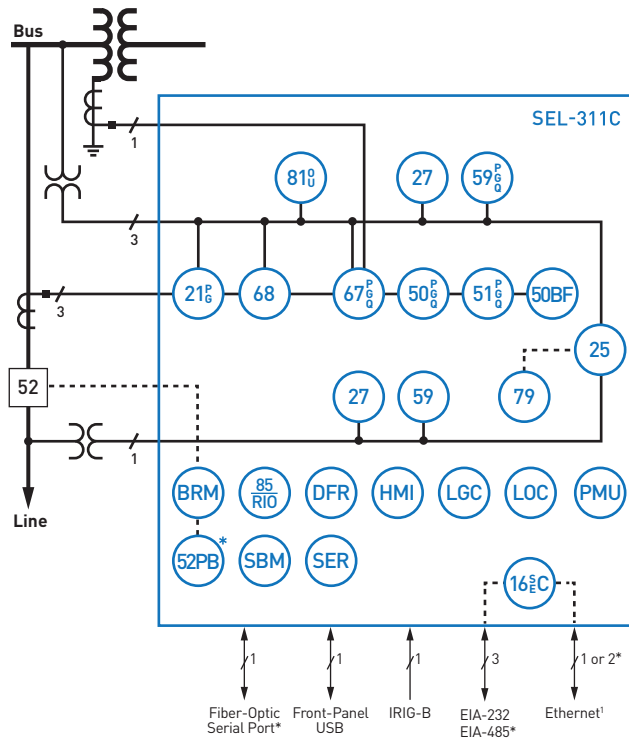

Figure 1 Functional Diagram

ANSI NUMBERS/ACRONYMS AND FUNCTIONS

16 SEC	Access Security (Serial, Ethernet)
21 (P, G)	Distance (Phase Mho, Ground Mho, Ground Quad)
25	Synchronism Check
27	Undervoltage
50 (P, G, Q)	Overcurrent (Phase, Ground, Neg. Seq.)
50BF	Breaker Failure Overcurrent
51 (P, G, Q)	Time-Overcurrent (Phase, Ground, Neg. Seq.)
52PB	Trip/Close Pushbuttons
59	Overvoltage
67 (P, G, Q)	Directional Overcurrent (Phase, Ground, Neg. Seq.)
68	Out-of-Step Block/Trip
79	Autoreclosing
81 (O, U)	Over-/Underfrequency
85 RIO	SEL MIRRORED BITS® Communications
DFR	Event Reports
HMI	Operator Interface
LGC	Expanded SELogic® Control Equations
MET	High-Accuracy Metering
PMU	Synchrophasors
SER	Sequential Events Recorder

ADDITIONAL FUNCTIONS

BRM	Breaker Wear Monitor
LDE	Load Encroachment
LOC	Fault Locator
SBM	Station Battery Monitor

¹ Copper or Fiber-Optic
* Optional Feature

Protection Features

The SEL-311C contains protective elements and control logic to protect overhead transmission lines and underground cables. It includes four zones of phase and ground mho distance elements, plus four zones of ground quadrilateral distance elements. These distance elements, together with overcurrent functions, are applied in com-

munications-assisted and stepped-distance protection schemes. You can further tailor the relay to your particular application using advanced SELOGIC control equations.

The relay has six independent setting groups. With this flexibility, the relay may be automatically configured for many operating conditions: substitute line relay, line configuration changes, source changes, etc.

Mho Distance Elements

The SEL-311C uses mho characteristics for phase- and ground-distance protection. Two zones are fixed in the forward direction, and the remaining two zones can be set for either forward or reverse. *Figure 2* illustrates an example of three forward zones and one reverse zone.

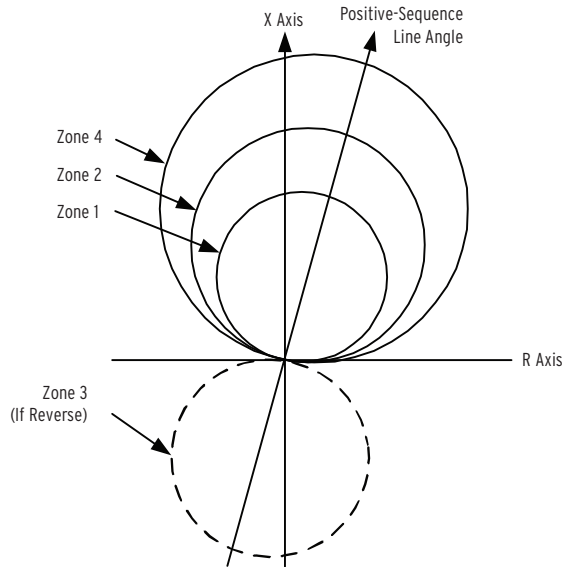

Figure 2 Phase and Ground Mho Distance Characteristics

All mho elements use positive-sequence memory polarization that expands the operating characteristic in proportion to the source impedance. This provides dependable, secure operation for close-in faults.

Figure 3 shows the forward-reaching mho characteristic for a forward phase-to-phase fault. The mho circle expands to the source impedance Z_S , but never more than the set relay reach, Z_R .

Depending on the application, the user can select from zero to four zones of distance protection.

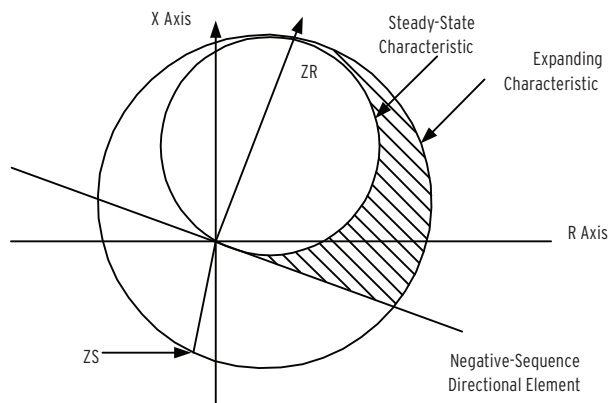

Figure 3 Phase-to-Phase Element Response for a Forward Phase-to-Phase Fault

Load Encroachment

Load-encroachment logic prevents operation of the phase-distance elements under high load conditions. This unique feature permits load to enter a predefined area of the phase-distance characteristic without causing a trip. *Figure 4* shows the load-encroachment characteristic.

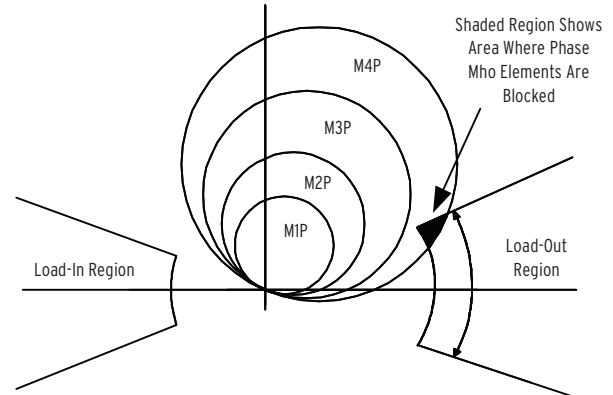

Figure 4 Load-Encroachment Characteristic

Quadrilateral Distance Elements

The SEL-311C provides four zones of quadrilateral ground-distance characteristics. The top line of the quadrilateral characteristic automatically tilts with load flow to avoid under- and overreaching. The ground mho and quadrilateral distance elements may be used individually, concurrently, or not at all.

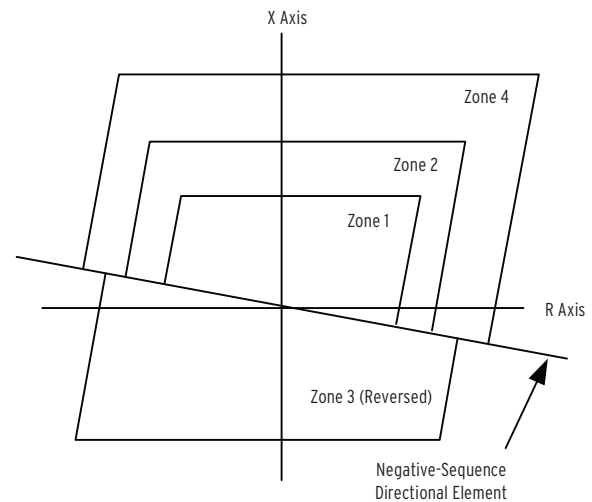

Figure 5 Quadrilateral Ground-Distance Characteristics

Each of the eight ground-distance elements has an individual reach setting. The ground-distance elements include two zero-sequence compensation factor settings (k_{01} , k_0) to accurately calculate ground fault impedance.

High-Speed Breaker Failure Protection

Detect a failed circuit breaker quickly with built-in breaker failure detection elements and logic. Dropout of conventional overcurrent elements can be extended by subsidence current, especially following high-current faults. The high-speed 50BF element drops out less than one cycle after successful breaker operation, even with subsidence current. Faster dropout times mean faster breaker failure detection and clearing times. Use the breaker failure trip and retrip timers to trigger dedicated breaker failure trip logic. Built-in breaker failure elements and logic save valuable programmable logic for other tasks.

Overcurrent Elements

The SEL-311C includes four phase, four negative-sequence, and four ground instantaneous overcurrent elements with torque control and definite-time functions. The SEL-311C also includes one phase, one negative-sequence, and one ground inverse time-overcurrent element, each with torque control.

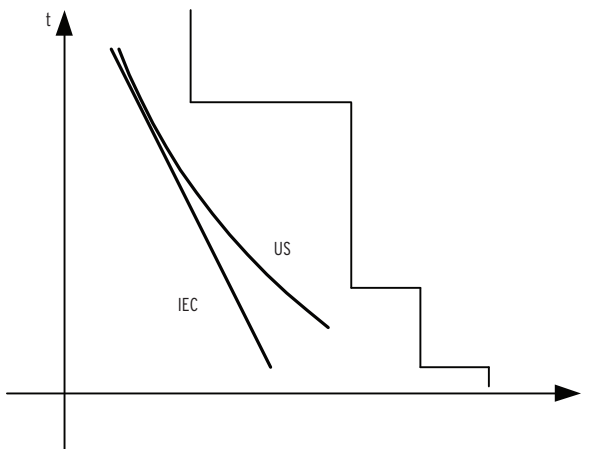

Figure 6 Instantaneous, Definite-Time, and Inverse Time-Overcurrent Characteristics

The time-overcurrent curves (shown in *Table 1*) have two reset characteristic choices for each time-overcurrent element. One choice resets the elements if current drops below pickup for at least one cycle. The other choice emulates the reset characteristic of an electromechanical induction disc relay.

Table 1 Time-Overcurrent Curves

U.S.	IEC
Moderately Inverse	Standard Inverse
Inverse	Very Inverse
Very Inverse	Extremely Inverse
Extremely Inverse	Long-Time Inverse
Short-Time Inverse	Short-Time Inverse

Directional Elements Increase Sensitivity and Security

Distance elements provide well-controlled reach. Directional overcurrent elements provide increased sensitivity.

Use ground and negative-sequence directional overcurrent elements to detect high-resistance faults when using communications-assisted tripping schemes.

The SEL-311C includes a number of directional elements that are used to supervise overcurrent elements and distance elements. The negative-sequence directional element can be applied in virtually any application regardless of the amount of negative-sequence voltage available at the relay location.

Ground overcurrent elements are directionally controlled by three directional elements working together:

- Negative-sequence voltage-polarized directional element
- Zero-sequence voltage-polarized directional element
- Zero-sequence current-polarized directional element

Our patented Best Choice Ground Directional Element logic selects the best ground directional element for the system conditions and simplifies directional element settings. You may override this automatic setting feature for special applications.

Undervoltage and Overvoltage Elements for Extra Protection and Control

Phase undervoltage, overvoltage, and sequence overvoltage elements help you create protection and control schemes, such as:

- Hot-bus, dead-line, or hot-line, dead-bus recloser control.
- Blown transformer high-side fuse detection logic.
- Undervoltage load shedding.

Frequency Elements

Six levels of over- (81O) or underfrequency (81U) elements detect abnormal system frequency. Use the independently time-delayed output of these elements to initiate load-shedding schemes. Phase undervoltage supervision prevents undesired frequency element operation during faults.

Metering and Monitoring

Complete Metering Capabilities

Extensive metering capabilities are provided by the SEL-311C, as shown in *Table 2*. Metering accuracies are provided in the *Specifications on page 23*.

Table 2 Metering Capabilities (Wye-Connected Voltages)

Quantities	Description
Currents $I_{A,B,C,N}$, I_G	Input currents and residual ground current ($I_G = 3I_0 = I_A + I_B + I_C$)
Voltages $V_{A,B,C}$, V_S	Wye-connected and synchronism-check voltage inputs
Power $MW_{A,B,C,3P}$ $MVAR_{A,B,C,3P}$	Single-phase and three-phase megawatts and megavars
Energy $MWh_{A,B,C,3P}$ $MVARh_{A,B,C,3P}$	Single-phase and three-phase megawatt and megavar hours, in and out
Power Factor $PF_{A,B,C,3P}$	Single-phase and three-phase power factor
Sequence I_1 , $3I_2$, $3I_0$, V_1 , V_2 , $3V_0$	Positive-, negative-, and zero-sequence currents and voltages
Frequency $FREQ$ (Hz)	Instantaneous power system frequency (monitored on channel V_A , or $3I_1$ when voltages are not connected)
Power Supply Vdc	Battery voltage
Demand and Peak Currents $I_{A,B,C,N,G}$, $3I_2$	Phase, neutral, ground, and negative-sequence currents
Demand and Peak Power $MW_{A,B,C,3P}$ $MVAR_{A,B,C,3P}$	Single- and three-phase megawatts and megavars, in and out

Event Reporting and Sequential Events Recorder

Event reports and Sequential Events Recorder features simplify post-fault analysis and help you improve your understanding of simple and complex protective scheme operations. They also aid in testing and troubleshooting relay settings and protection schemes.

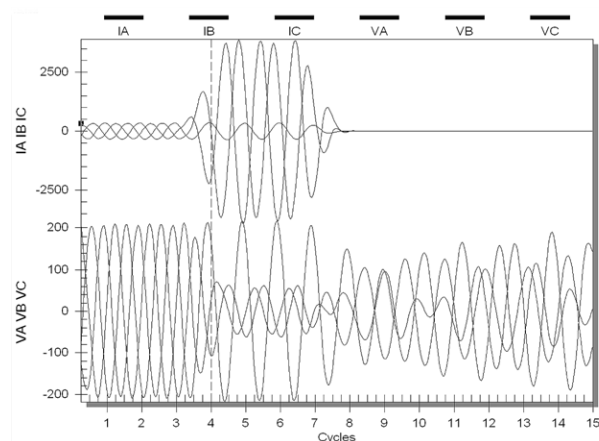

Figure 7 SEL-5601 Graph Event Reports

In response to a user-selected trigger, the voltage, current, and element status information contained in each event report confirms relay, scheme, and system performance for every fault. Decide how much detail is necessary when you request an event report: 1/4-cycle, 1/16-cycle, 1/32-cycle, or 1/128-cycle resolution, filtered, or raw analog data. For each report the relay stores the most recent 15, 30, 60, or 180 cycles of data in nonvolatile memory. The relay stores a total of 12 seconds of event report data. Relay settings active at the event trigger are appended to the bottom of each event report.

Event report information can be used in conjunction with the ACSELERATOR Analytic Assistant® SEL-5601 Software to produce oscillographic type reports suitable for inclusion in analysis documents and reports. An example of event report data showing an A-B-G fault is presented in *Figure 7* and *Figure 8*.

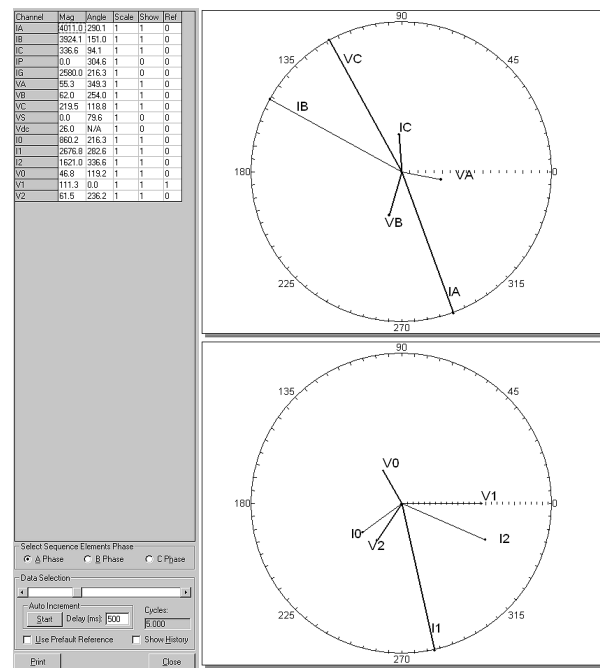

Figure 8 SEL-5601 Phasors

Event Summary

Each time the relay generates a standard event report, it also generates a corresponding event summary. This is a concise description of an event that includes the following information:

- Relay identification
- Event date and time
- Event type
- Fault location
- Recloser shot count at time of trigger
- System frequency at time of trigger
- Fault type at time of trip
- Prefault and fault phase and polarizing current levels
- Prefault and fault calculated zero- and negative-sequence currents
- Phase voltages
- Status of all MIRRORED BITS channels
- Trip and close times of day
- Breaker status (open/close)
- Fault resistance

With an appropriate setting, the relay will automatically send an event summary in ASCII text to one or more ports each time an event report is triggered.

Sequential Events Recorder

The relay SER stores the latest 1024 entries. Use this feature to gain a broad perspective of relay element operation. Items for triggering an SER entry include: input/output change of state, element pickup/dropout, recloser state changes, etc.

The IRIG-B time-code input synchronizes the SEL-311C SER time stamps to within 1 ms of the time-source input. A convenient source for this time code is a communications processor (via Serial Port 2 on the SEL-311C) or an SEL-2407[®] Satellite-Synchronized Clock or SEL-2401 clock. The optional SEL-2812-compatible fiber-optic serial port is also an IRIG-B source when paired with a compatible serial transceiver that transmits IRIG-B.

The relay also synchronizes the internal clock to an NTP server via SNTP with 5 ms accuracy. Connect all possible time sources (IRIG, SNTP, DNP) and the relay automatically selects the most accurate.

Synchrophasor Measurements

Send synchrophasor data using IEEE C37.118-2005 protocol to SEL synchrophasor applications. These include the SEL-3378 Synchrophasor Vector Processor (SVP), SEL-3530 Real-Time Automation Controller (RTAC), and the SEL SYNCHROWAVE[®] software suite. The SEL-3378 SVP enables control applications based on synchrophasors. Directly measure the oscillation modes of your power system. Act on the result. Properly control islanding of distributed generation using wide-area phase angle slip and acceleration measurements. With the SVP you have the power to customize synchrophasor control applications based on the unique requirements of your power sys-

tem. Then use SEL SYNCHROWAVE software to archive and display wide-area system measurements, which are precisely time-aligned using synchrophasor technology.

The data rate of SEL-311C synchrophasors is selectable, with a range of one to sixty messages per second. This flexibility is important for efficient use of communication capacity. The SEL-311C phasor measurement accuracy meets the highest IEEE C37.118-2005 Level 1 requirement of 1 percent total vector error (TVE). This means you can use the low-cost SEL-311C in any application that otherwise would have required purchasing a separate dedicated phasor measurement unit (PMU).

Backward compatibility with the SEL Fast Message Protocol is maintained in the SEL-311C. Send data from one message per second to slower rates such as one message per minute using this protocol. The slow data rates are useful for integration into an existing SCADA scan rate. Use with the SEL communications processors, or the SEL-3530 RTAC, to change nonlinear state estimation into linear state estimation. If all necessary lines include synchrophasor measurements then state estimation is no longer necessary. The system state is directly measured.

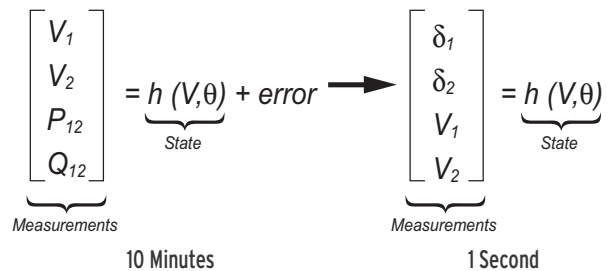

Figure 9 Synchrophasor Measurements Turn State Estimation Into State Measurement

Improve Situational Awareness

Provide improved information to system operators. Advanced synchrophasor-based tools provide a real-time view of system conditions. Use system trends, alarm points, and pre-programmed responses to help operators prevent a cascading system collapse and maximize system stability. Awareness of system trends provides operators with an understanding of future values based on measured data.

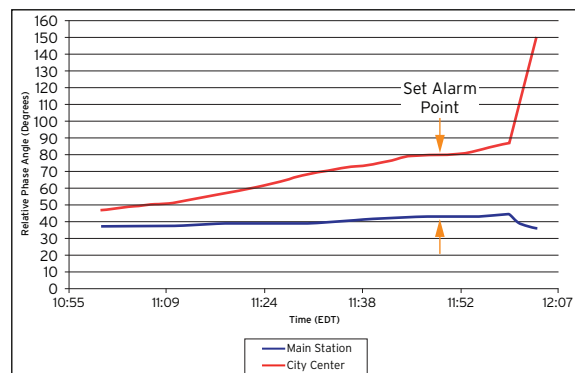

Figure 10 Visualization of Phase Angle Measurements Across a Power System

- Increase system loading while maintaining adequate stability margins.
- Improve operator response to system contingencies such as overload conditions, transmission outages, or generator shutdown.
- Advance system knowledge with correlated event reporting and real-time system visualization.
- Validate planning studies to improve system load balance and station optimization.

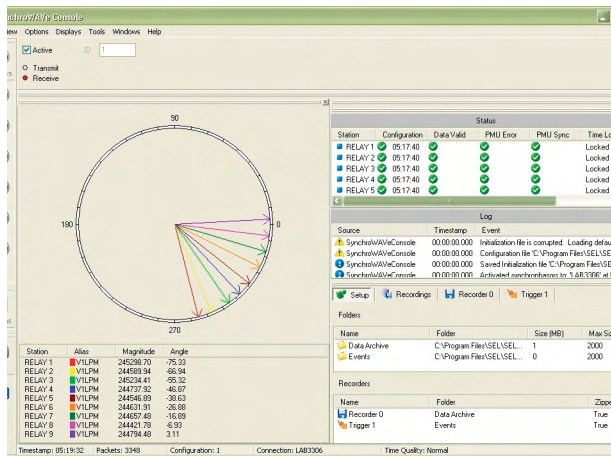

Figure 11 SEL-5078 SYNCHROWAVE Console Software Provides a Real-Time, Wide-Area Visualization Tool

Substation Battery Monitor for DC Quality Assurance

The SEL-311C measures and reports the substation battery voltage presented to its power supply terminals. The relay includes two programmable threshold comparators and associated logic for alarm and control. For example, if the battery charger fails, the measured dc voltage falls below a programmable threshold and operations personnel are then notified before the substation battery voltage falls to unacceptable levels. Monitor these thresholds with an SEL communications processor and trigger messages, telephone calls, or other actions.

The measured dc voltage is reported in the METER display via communications, on the LCD, and in the event report. Use the event report data to see an oscillographic display of the battery voltage. You can see how much the substation battery voltage drops during trip, close, and other control operations.

Breaker Monitor Feature Allows for Intelligent Breaker Maintenance Scheduling

Circuit breakers experience mechanical and electrical wear every time they operate. Effective scheduling of breaker maintenance takes into account the manufacturer's

published data of contact wear versus interruption levels and operation count. The SEL-311C breaker monitor feature compares the breaker manufacturer's published data to the interrupted current.

Each time a monitored breaker trips, the relay integrates the interrupted current with previously stored current values. When the results exceed the threshold set by the breaker wear curve (Figure 12), the relay initiates an alarm via an output contact or the front-panel display. The typical settings shown in Figure 12 are:

- Set Point 1 approximates the continuous load current rating of the breaker
- Set Point 3 is the maximum rated interrupting current for the particular breaker
- Set Point 2 is some intermediate current value that provides the closest visual "fit" to the manufacturer's curve

The wear for each pole of each monitored breaker is calculated separately since the breaker monitor accumulates current by phase. When first applying the relay, preload any previous estimated breaker wear. The incremental wear for the next interruption, and all subsequent interruptions, is added to the prestored value for a total wear value. Reset the breaker monitor operation counters, cumulative interrupted currents by pole, and percent wear by pole after breaker maintenance or installing a new breaker.

The breaker monitor report lists the number of internal and external trips for each breaker, the total accumulated rms current by phase, and the percent wear by pole. The relay monitors and records electrical and mechanical breaker operate times and minimum dc voltage for open and close operations. Use the settable alarm thresholds to issue warning alarms for slow mechanical or electrical trip or close operations. Inspect reports for the most recent operation, or gather trending data for as many as 128 previous operations. Retrieve breaker monitor reports through FTP or Manufacturing Message Specification (MMS) file transfer.

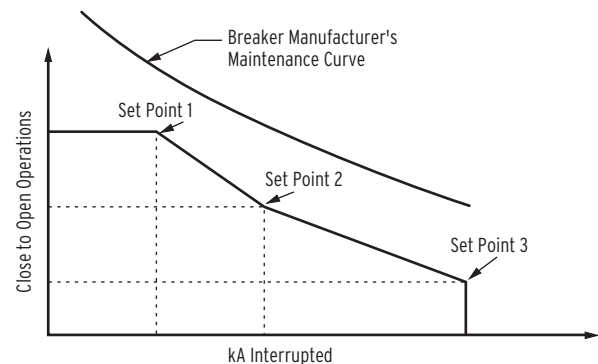

Figure 12 Breaker Contact Wear Curve and Settings

Operator Controls and Reclosing

Optional Operator Controls Eliminate Traditional Panel Control Switches

Ten programmable operator pushbutton controls and associated programmable LEDs are available, eliminating the need for traditional panel control switches and lights. Change operator control and LED functions using SELOGIC control equations and configurable labels. The Sequential Events Recorder (SER) report can be set to track operator controls.

Optional SafeLock Trip/Close Pushbuttons and Indicating LEDs

Optional SafeLock trip/close pushbuttons (see *Figure 13*) and bright indicating LEDs allow breaker control independent of the relay. The trip/close pushbuttons are electrically separate from the relay, operating even if the relay is powered down. Make the extra connections at terminals Z15 through Z22. See *Figure 27* through *Figure 28* for front-panel and rear-panel views. *Figure 14* shows one possible set of connections.

The trip/close pushbuttons incorporate an arc suppression circuit for interrupting dc trip or close current to protect the internal electrical contacts. To use these pushbuttons with ac trip or close circuits, disable the arc suppression for either pushbutton by changing jumpers inside the SEL-311C. The operating voltage ranges of the BREAKER CLOSED and BREAKER OPEN indicating LEDs are also jumper selectable.

Note: The SafeLock trip/close pushbuttons and breaker status LEDs always have configurable labels.

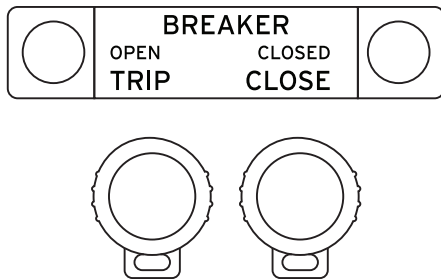

Figure 13 SafeLock Trip/Close Pushbuttons and Indicators

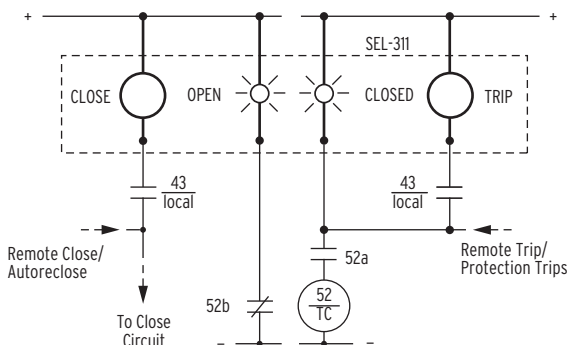

Figure 14 Optional SafeLock Trip/Close Pushbuttons and Indicating LEDs

Local and Remote Control Example

Under certain operating conditions it is desirable to temporarily disable ground fault protection. This is accomplished in a variety of ways using SELOGIC control equations with local and remote control. As shown in *Figure 15*, achieve remote disable/enable control using an optoisolated input or communications port. The local control switch function handles local disable/enable control. Output contacts, ports and the local LCD display points indicate ground relay operating status. Local and remote control capabilities require programming SELOGIC control equations.

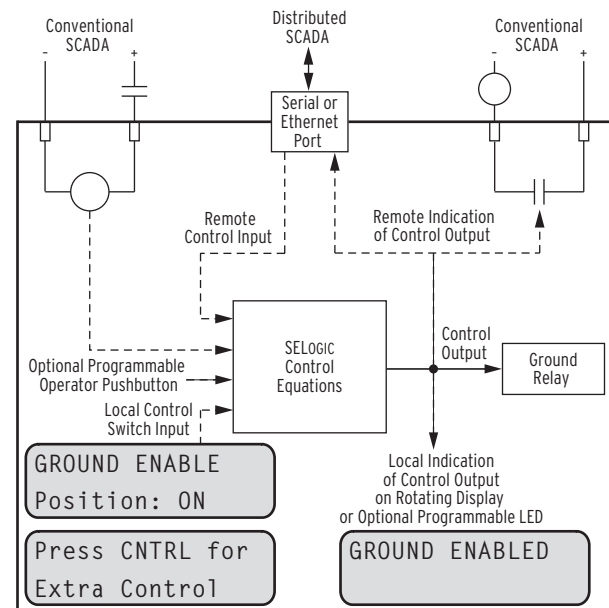

Figure 15 Local and Remote Control Using SELogic Control Equations (Ground Relay Example)

Programmable Autoreclosing

The SEL-311C autoreclose flexibility allows many different reclosing strategies to meet traditional and custom requirements. The SEL-311C can autoreclose a circuit breaker as many as four times before lockout. Use SELOGIC control equations to enable and disable reclosing, define reclose initiation and supervision conditions, shot counter advance and drive-to-lockout conditions, close supervision and close failure conditions, and open interval timer start and stall conditions. Separate time

delays are available for reset-from-successful-reclose and reset-from-lockout conditions. The reset timer can be stalled if the relay detects an overcurrent condition after the breaker closes to prevent the recloser from resetting before the relay trips on a permanent slow-clearing fault.

Program the SEL-311C to perform unconditional reclose, conditional reclose using voltage check and synchrocheck functions, and even autosynchronizing when the two systems are asynchronous. The front-panel LEDs (RESET and LOCKOUT) track the recloser state.

Relay and Logic Settings Software

ACSELERATOR QuickSet[®] SEL-5030 Software program uses the Microsoft[®] Windows[®] operating system to simplify settings and provide analysis support for the SEL-311C.

Use ACSELERATOR QuickSet to create and manage relay settings and analyze events:

- ▶ Develop settings offline with an intelligent settings editor that only allows valid settings.
- ▶ Create SELOGIC control equations with a drag and drop graphical editor and/or text editor.
- ▶ Use online help to assist with configuring proper settings.
- ▶ Organize settings with the relay database manager.
- ▶ Load and retrieve settings using a simple PC communications link.

- ▶ Enter settings into a settings template generated with licensed versions of the SEL ACSELERATOR QuickSet software. Send resulting settings and the template to the relay with a single action. When reading settings from the relay, ACSELERATOR QuickSet also retrieves the template and compares the settings generated by the template to those in use by the relay, alerting you to any differences.
- ▶ Analyze power system events with the integrated waveform and harmonic analysis tools.

Use ACSELERATOR QuickSet to aid with monitoring, commissioning, and testing the SEL-311C:

- ▶ Use the human-machine interface (HMI) to monitor meter data, Relay Word bits, and output contacts status during testing.
- ▶ Use the PC interface to remotely retrieve breaker wear and other power system data.

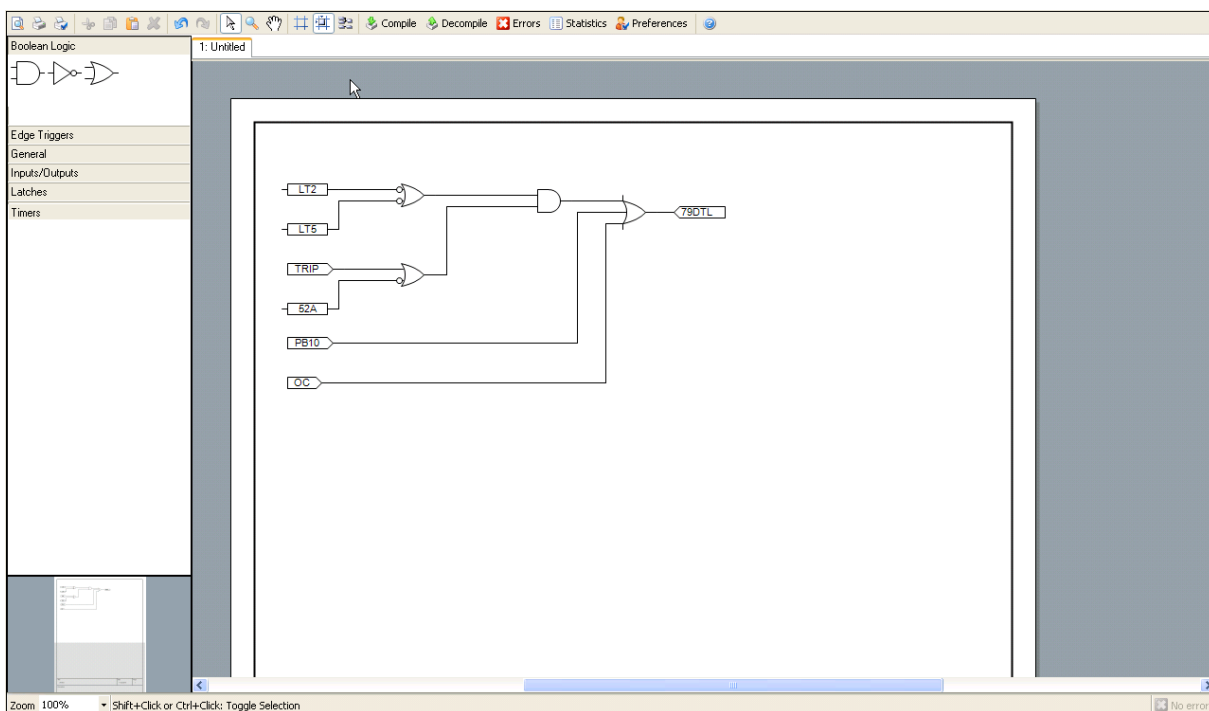

Figure 16 ACSELERATOR QuickSet Software Screen

Fault Locator

The SEL-311C provides an accurate fault location calculation even during periods of substantial load flow. The fault locator uses fault type, replica line impedance settings, and fault conditions to calculate fault location without communications channels, special instrument transformers, or pre-fault information. This feature contributes to efficient dispatch of line crews and fast restoration of service.

Fault location quantities include distance to fault, per-unit distance to fault, impedance to fault location, and fault resistance. These fault location quantities are provided in the event reports and event summaries.

Integrated Web Server

An embedded web server is included in every SEL-311C relay. Browse to the relay with any standard web browser to safely read settings, verify relay self-test status, inspect meter reports, and read relay configuration and event history. The web server allows no control or modification actions at Access Level 1 (ACC), so users can be confident that an inadvertent button press will have no adverse effects. *Figure 17* shows an example of a settings display web page.

The web server allows users with the appropriate engineering access level (2AC) to upgrade the firmware over an Ethernet connection. An Ethernet port setting enables or disables this feature, with the option of requiring front-panel confirmation when the file is completely uploaded.

The SEL-311C firmware files contain cryptographic signatures that enable the SEL-311C to recognize official SEL firmware. A digital signature, computed using the Secure Hash Algorithm 1 (SHA-1), is appended to the compressed firmware file. Once the firmware is fully uploaded to the relay, the relay verifies the signature using a Digital Signature Algorithm security key that SEL stored on the device. If the signature is valid, the firmware is upgraded in the relay. If the relay cannot verify the signature, it reverts back to the previously installed firmware.

SEL-311C Active Group Settings (SHO)			
Group 1 Settings:			
RID = SEL-311	CTR = 200	CTRN = 200	TID = STATION A
VNOM = 67.00	Z1MAG = 7.80	Z1ANG = 84.00	PTR = 560.00
LL = 100.00	E21XG = 3	EADV = N	PTRS = 560.00
E51P = N	E32 = AUTO	E5OP = 1	ZOMAG = 24.80
EDD, SOTF = Y	ELOP = Y	E51G = Y	E21P = 3
E79 = N	Z1P = 6.24	E00S = N	E50G = N
50PP1 = 0.50	50GZ1 = 0.50	EVOLT = N	E51Q = Y
Z1MG = 6.24	KQM1 = 0.726	EBBPT = N	ELOAD = Y
XG1 = 6.24	Z2GD = 20.00	ECCVT = N	E25 = N
RG1 = 2.50	Z3D = OFF	ESV = 1	ECOMM = POTT
50L1 = 0.50	Z3GD = OFF	Z2P = 9.36	ESV = 1
KQA1 = -3.89	51GP = 0.75	Z3P = 1.87	E81 = N
Z1PD = OFF	51QP = 2.20	Z3MG = 1.87	EDEM = THM
Z2GD = 20.00	Z1F = 6.50	XG2 = 9.36	
Z3D = OFF	PLAR = 150.00	XG3 = 1.87	
50P1P = 15.00	DIR3 = R	RG2 = 5.00	
67P1D = 0.00	ORDER = QVI	50GZ1 = 0.50	
51GP = 0.75	50QRP = 0.25	KQA1 = -3.89	
51QP = 2.20	50GRP = 0.25	Z2PD = 20.00	
Z1F = 6.50		Z3GD = OFF	
PLAR = 150.00		Z3D = OFF	
DIR3 = R		Z3P = 1.87	
ORDER = QVI		Z3MG = 1.87	
50QRP = 0.25		XG2 = 9.36	
50GRP = 0.25		XG3 = 1.87	
		RG2 = 5.00	
		50GZ1 = 0.50	
		KQA1 = -3.89	
		Z2PD = 20.00	
		Z3GD = OFF	
		Z3D = OFF	
		Z3P = 1.87	
		Z3MG = 1.87	
		XG2 = 9.36	
		XG3 = 1.87	
		RG2 = 5.00	
		50GZ1 = 0.50	
		KQA1 = -3.89	
		Z2PD = 20.00	
		Z3GD = OFF	
		Z3D = OFF	
		Z3P = 1.87	
		Z3MG = 1.87	
		XG2 = 9.36	
		XG3 = 1.87	
		RG2 = 5.00	
		50GZ1 = 0.50	
		KQA1 = -3.89	
		Z2PD = 20.00	
		Z3GD = OFF	
		Z3D = OFF	
		Z3P = 1.87	
		Z3MG = 1.87	
		XG2 = 9.36	
		XG3 = 1.87	
		RG2 = 5.00	
		50GZ1 = 0.50	
		KQA1 = -3.89	
		Z2PD = 20.00	
		Z3GD = OFF	
		Z3D = OFF	
		Z3P = 1.87	
		Z3MG = 1.87	
		XG2 = 9.36	
		XG3 = 1.87	
		RG2 = 5.00	
		50GZ1 = 0.50	
		KQA1 = -3.89	
		Z2PD = 20.00	
		Z3GD = OFF	
		Z3D = OFF	
		Z3P = 1.87	
		Z3MG = 1.87	
		XG2 = 9.36	
		XG3 = 1.87	
		RG2 = 5.00	
		50GZ1 = 0.50	
		KQA1 = -3.89	
		Z2PD = 20.00	
		Z3GD = OFF	
		Z3D = OFF	
		Z3P = 1.87	
		Z3MG = 1.87	
		XG2 = 9.36	
		XG3 = 1.87	
		RG2 = 5.00	
		50GZ1 = 0.50	
		KQA1 = -3.89	
		Z2PD = 20.00	
		Z3GD = OFF	
		Z3D = OFF	
		Z3P = 1.87	
		Z3MG = 1.87	
		XG2 = 9.36	
		XG3 = 1.87	
		RG2 = 5.00	
		50GZ1 = 0.50	
		KQA1 = -3.89	
		Z2PD = 20.00	
		Z3GD = OFF	
		Z3D = OFF	
		Z3P = 1.87	
		Z3MG = 1.87	
		XG2 = 9.36	
		XG3 = 1.87	
		RG2 = 5.00	
		50GZ1 = 0.50	
		KQA1 = -3.89	
		Z2PD = 20.00	
		Z3GD = OFF	
		Z3D = OFF	
		Z3P = 1.87	
		Z3MG = 1.87	
		XG2 = 9.36	
		XG3 = 1.87	
		RG2 = 5.00	
		50GZ1 = 0.50	
		KQA1 = -3.89	
		Z2PD = 20.00	
		Z3GD = OFF	
		Z3D = OFF	
		Z3P = 1.87	
		Z3MG = 1.87	
		XG2 = 9.36	
		XG3 = 1.87	
		RG2 = 5.00	
		50GZ1 = 0.50	
		KQA1 = -3.89	
		Z2PD = 20.00	
		Z3GD = OFF	
		Z3D = OFF	
		Z3P = 1.87	
		Z3MG = 1.87	
		XG2 = 9.36	
		XG3 = 1.87	
		RG2 = 5.00	
		50GZ1 = 0.50	
		KQA1 = -3.89	
		Z2PD = 20.00	
		Z3GD = OFF	
		Z3D = OFF	
		Z3P = 1.87	
		Z3MG = 1.87	
		XG2 = 9.36	
		XG3 = 1.87	
		RG2 = 5.00	
		50GZ1 = 0.50	
		KQA1 = -3.89	
		Z2PD = 20.00	
		Z3GD = OFF	
		Z3D = OFF	
		Z3P = 1.87	
		Z3MG = 1.87	
		XG2 = 9.36	
		XG3 = 1.87	
		RG2 = 5.00	
		50GZ1 = 0.50	
		KQA1 = -3.89	
		Z2PD = 20.00	
		Z3GD = OFF	
		Z3D = OFF	
		Z3P = 1.87	
		Z3MG = 1.87	
		XG2 = 9.36	
		XG3 = 1.87	
		RG2 = 5.00	
		50GZ1 = 0.50	
		KQA1 = -3.89	
		Z2PD = 20.00	
		Z3GD = OFF	
		Z3D = OFF	
		Z3P = 1.87	
		Z3MG = 1.87	
		XG2 = 9.36	
		XG3 = 1.87	
		RG2 = 5.00	
		50GZ1 = 0.50	
		KQA1 = -3.89	
		Z2PD = 20.00	
		Z3GD = OFF	
		Z3D = OFF	
		Z3P = 1.87	
		Z3MG = 1.87	
		XG2 = 9.36	
		XG3 = 1.87	
		RG2 = 5.00	
		50GZ1 = 0.50	
		KQA1 = -3.89	
		Z2PD = 20.00	
		Z3GD = OFF	
		Z3D = OFF	
		Z3P = 1.87	
		Z3MG = 1.87	
		XG2 = 9.36	
		XG3 = 1.87	
		RG2 = 5.00	
		50GZ1 = 0.50	
		KQA1 = -3.89	
		Z2PD = 20.00	
		Z3GD = OFF	
		Z3D = OFF	
		Z3P = 1.87	
		Z3MG = 1.87	
		XG2 = 9.36	
		XG3 = 1.87	
		RG2 = 5.00	
		50GZ1 = 0.50	
		KQA1 = -3.89	
		Z2PD = 20.00	
		Z3GD = OFF	
		Z3D = OFF	
		Z3P = 1.87	
		Z3MG = 1.87	
		XG2 = 9.36	
		XG3 = 1.87	
		RG2 = 5.00	
		50GZ1 = 0.50	
		KQA1 = -3.89	
		Z2PD = 20.00	
		Z3GD = OFF	
		Z3D = OFF	
		Z3P = 1.87	
		Z3MG = 1.87	
		XG2 = 9.36	
		XG3 = 1.87	
		RG2 = 5.00	
		50GZ1 = 0.50	
		KQA1 = -3.89	
		Z2PD = 20.00	
		Z3GD = OFF	
		Z3D = OFF	
		Z3P = 1.87	
		Z3MG = 1.87	
		XG2 = 9.36	
		XG3 = 1.87	
		RG2 = 5.00	
		50GZ1 = 0.50	
		KQA1 = -3.89	
		Z2PD = 20.00	
		Z3GD = OFF	
		Z3D = OFF	
		Z3P = 1.87	
		Z3MG = 1.87	
		XG2 = 9.36	
		XG3 = 1.87	
		RG2 = 5.00	
		50GZ1 = 0.50	
		KQA1 = -3.89	
		Z2PD = 20.00	
		Z3GD = OFF	
		Z3D = OFF	
		Z3P = 1.87	
		Z3MG = 1.87	
		XG2 = 9.36	
		XG3 = 1.87	
		RG2 = 5.00	
		50GZ1 = 0.50	
		KQA1 = -3.89	
		Z2PD = 20.00	
		Z3GD = OFF	
		Z3D = OFF	
		Z3P = 1.87	
		Z3MG = 1.87	
		XG2 = 9.36	
		XG3 = 1.87	
		RG2 = 5.00	
		50GZ1 = 0.50	
		KQA1 = -3.89	
		Z2PD = 20.00	
		Z3GD = OFF	
		Z3D = OFF	
		Z3P = 1.87	
		Z3MG = 1.87	
		XG2 = 9.36	
		XG3 = 1.87	
		RG2 = 5.00	
		50GZ1 = 0.50	
		KQA1 = -3.89	
		Z2PD = 20.00	
		Z3GD = OFF	
		Z3D = OFF	
		Z3P = 1.87	
		Z3MG = 1.87	
		XG2 = 9.36	
		XG3 = 1.87	
		RG2 = 5.00	
		50GZ1 = 0.50	
		KQA1 = -3.89	
		Z2PD = 20.00	
		Z3GD = OFF	
		Z3D = OFF	
		Z3P = 1.87	
		Z3MG = 1.87	
		XG2 = 9.36	
		XG3 = 1.87	
		RG2 = 5.00	
		50GZ1 = 0.50	
		KQA1 = -3.89	
		Z2PD = 20.00	
		Z3GD = OFF	

Communications

Ethernet, Serial, and USB Port Features

The SEL-311C Transmission Protection System is equipped with two 10/100BASE-T Ethernet ports on the rear panel and three independently-operated serial ports: one EIA-232 serial port on the front panel, a USB port on the front panel, and two EIA-232 serial ports on the rear panel. Communications port ordering options include replacing the standard metallic Ethernet ports with a 100BASE-FX optical Ethernet port, dual-redundant 100BASE-FX optical Ethernet ports, or with one 10/100BASE-T metallic and one 100BASE-FX fiber port. Additional options include an isolated EIA-485 rear-panel port or SEL-2812-compatible rear-panel fiber-optic port. The USB Type-B port on the front panel allows for fast local communications. A special driver required for USB communications is provided with the product literature CD.

The relay does not require special communications software. Use any system that emulates a standard terminal system. Establish communications by connecting computers, modems, protocol converters, data concentrators, port switchers, communications processors, and printers.

Connect multiple SEL-311C relays to an SEL communications processor, an SEL real-time automation controller (RTAC), and SEL computing platform, or an SEL synchrophasor vector processor for advanced data collection, protection, and control schemes (see *Figure 18*).

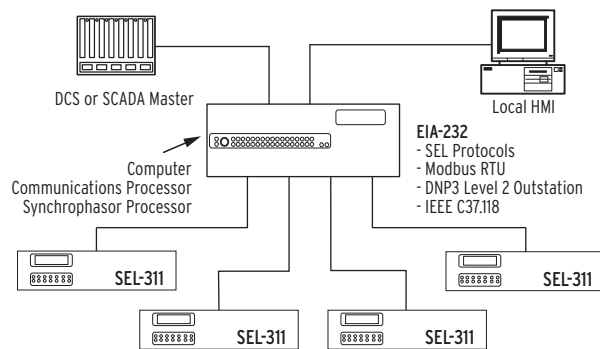

Figure 18 Typical Serial Communications Architecture

SEL manufactures a variety of standard cables for connecting this and other relays to a variety of external devices. Consult your SEL representative for more information on cable availability. The SEL-311C can communicate directly with SCADA systems, computers, and RTUs via serial or Ethernet port for local or remote communications (see *Figure 19*).

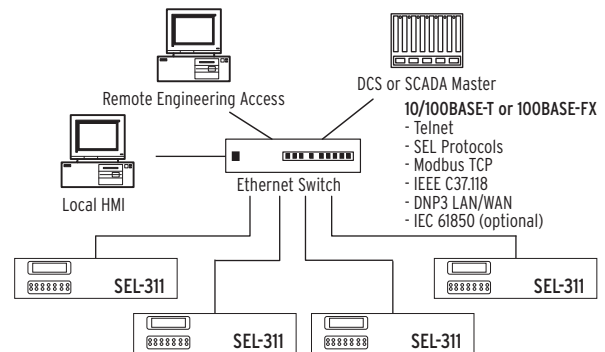

Figure 19 Typical Ethernet Communications Architecture

Dual-Port Ethernet Network Configuration Options

The dual-port Ethernet option increases network reliability and availability by incorporating the relay with external managed or unmanaged switches. Implement a self-healing ring structure with managed switches, or use unmanaged switches in a dual-redundant configuration (see *Figure 20* and *Figure 21*).

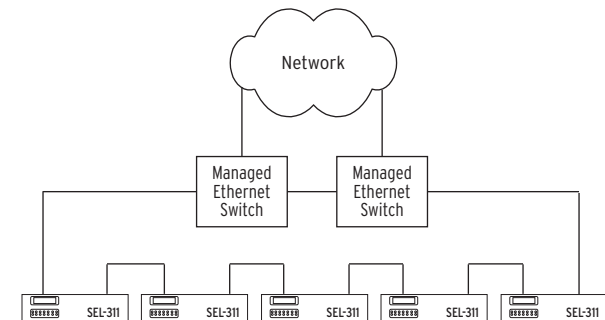

Figure 20 Self-Healing Ring Using Internal Ethernet Switch

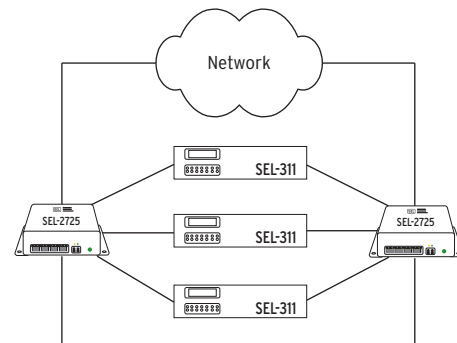

Figure 21 Failover Network Topology

Table 3 lists the communications protocols available on the SEL-311C for protection, monitoring, control, interrogation, setting, and reporting.

Table 3 Open Communications Protocols

Type	Description
IEC 61850	Ethernet-based international standard for interoperability between intelligent devices in a substation. Operates remote bits, breaker controls, and I/O. Monitors Relay Word bits and analog quantities. Use MMS file transfer to retrieve COMTRADE file format event reports.
Simple ASCII	Plain language commands for human and simple machine communications. Use for metering, setting, self-test status, event reporting, and other functions.
Compressed ASCII	Comma-delimited ASCII data reports. Allows external devices to obtain relay data in an appropriate format for direct import into spreadsheets and database programs. Data are checksum protected.
Extended Fast Meter and Fast Operate	Serial or Telnet binary protocol for machine-to-machine communications. Quickly updates SEL communications processors, RTUs, and other substation devices with metering information, relay element and I/O status, time-tags, open and close commands, and summary event reports. Data are checksum protected. Binary and ASCII protocols operate simultaneously over the same communications lines so binary SCADA metering information is not lost while an engineer or technician is transferring an event report or communicating with the relay using ASCII communications through the same relay communications port.
SEL Distributed Port Switch (LMD) Protocol	Enables multiple SEL devices to share a common communications bus (two-character address setting range is 01–99). Use this protocol for low-cost, port-switching applications.
Fast SER Protocol	Provides serial or Ethernet SER data transfers with original time stamps to an automated data collection system.
Modbus RTU or TCP	Serial or Ethernet-based Modbus with point remapping. Includes access to metering data, protection elements, contact I/O, targets, relay summary events, and settings groups.
DNP3 Serial or LAN/WAN	Serial or Ethernet-based Distributed Network Protocol with point remapping. Includes access to metering data, protection elements, contact I/O, targets, SER, relay summary event reports, and setting groups.
IEEE C37.118-2005	Serial or Ethernet Phasor Measurement Protocol. Streams synchrophasor data to archiving historian for post-disturbance analysis, to visualization software for real-time monitoring, or to synchrophasor data processor for real-time control.

Automation

Control Logic and Integration

SEL-311C control logic improves integration in the following ways:

- **Replace traditional panel control switches.** Ten conveniently sized programmable operator push-button controls and programmable LEDs are available, eliminating the need for traditional panel control switches and lights. In addition, as many as 16 local control switch functions (Local Bits LB1–LB16) can be programmed for operation through the CNTRL front-panel pushbutton. Set, clear, or pulse selected Local Bits and program the front-panel operator pushbuttons and LEDs and the Local Bits into your control scheme with SELOGIC control equations. Use the Local Bits to perform functions such as turning ground tripping and auto-reclosing on and off or a breaker trip/close.
- **Eliminate RTU-to-relay wiring.** Use serial or LAN/WAN communications to control as many as 32 remote control switches (Remote Bits RB1–RB32). Set, clear, or pulse selected Remote Bits over serial port or network communications using ASCII, DNP, or Modbus commands. Program the Remote Bits into your control scheme with SELOGIC control equations. Use Remote Bits for SCADA-type control operations such as trip, close, and turning autoreclose on or off.
- **Replace traditional latching relays.** Perform traditional latching relay functions, such as “remote control enable”, with 16 internal logic latch control switches (Latch Bits LT1–LT16). Program latch set and latch reset conditions with SELOGIC control equations. Set or reset the nonvolatile Latch Bits using optoisolated inputs, remote control switches, local control switches, or any programmable logic condition. The Latch Bits retain their state when the relay loses power.
- **Replace traditional indicating panel lights.** Use optional programmable LEDs or 16 programmable rotating messages on the front-panel LCD display to define custom text messages (e.g., Breaker Open, Breaker Closed, and real-time analog quantities) that report power system or relay conditions. Use SELOGIC control equations to control which rotating display messages are displayed.
- **Eliminate external timers.** Provide custom protection or control schemes with 16 general purpose SELOGIC control equation timers. Each timer has independent time-delay pickup and dropout settings. Program each timer input with any desired element (e.g., time qualify a current element). Assign the timer output to trip logic, transfer trip communications, or other control scheme logic.

Fast SER Protocol

SEL Fast Sequential Events Recorder Protocol provides SER events to an automated data collection system. SEL Fast SER Protocol is available on any port. Devices with embedded processing capability can use these messages to enable and accept unsolicited binary SER messages from SEL-311C Relays.

SEL relays and communications processors have two separate data streams that share the same serial port. The normal serial interface consists of ASCII character commands and reports that are intelligible to people using a terminal or terminal emulation package. The binary data streams can interrupt the ASCII data stream to obtain information, and then allow the ASCII data stream to continue. This mechanism allows a single

communications channel to be used for ASCII communications (e.g., transmission of a long event report) interleaved with short bursts of binary data to support fast acquisition of metering or SER data.

Security Features

The SEL-311C allows unused serial and Ethernet ports to be individually disabled. To control unauthorized access, the maximum access level (privilege) may be set independently for each port. Unsuccessful access attempts, elevated access, and Ethernet link status may be monitored locally or remotely.

For firmware upgrades, source authenticity is ensured with digitally signed firmware upgrade files.

Added Capabilities

MIRRORED BITS Communications

The SEL-patented MIRRORED BITS communications technology provides bidirectional digital communications between any two MIRRORED BITS-capable devices. MIRRORED BITS can operate independently on as many as two EIA-232 serial ports on a single SEL-311C.

This bidirectional digital communication creates eight additional virtual outputs (transmitted MIRRORED BITS) and eight additional virtual inputs (received MIRRORED BITS) for each serial port operating in the MIRRORED BITS mode (see *Figure 22*). Use these MIRRORED BITS to transmit/receive information between relays for communications-assisted tripping. MIRRORED BITS technology also helps reduce total scheme operating time by eliminating the need to assert output contacts to transmit information.

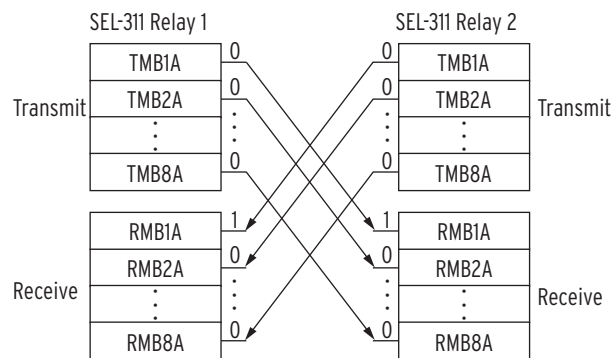

Channel A Relay Word bits shown. Channel B Relay Word bits are TMB1B to TMB8B and RMA1B to RMA8B.

Figure 22 MIRRORED BITS Transmit and Receive Relay Word Bits (Shown for Channel A)

Loss-of-Potential (LOP) Logic Supervises Directional Elements

The SEL-311C includes logic that detects blown potential fuses. Loss-of-potential affects distance and directional element performance. Simple user settings configure LOP logic to either block or enable-forward ground and phase directional elements.

Advanced SELOGIC Control Equations

Advanced SELOGIC control equations put relay logic in the hands of the protection engineer. Assign the relay inputs to suit your application, logically combine selected relay elements for various control functions, and assign outputs to your logic functions.

Programming SELOGIC control equations consists of combining relay elements, inputs, and outputs with SELOGIC control equation operators. Any element in the Relay Word can be used in these equations.

The SELOGIC control equation operators include the following: OR, AND, invert, parentheses, and rising and falling edges of element state changes.

Sixteen general-purpose SELOGIC control equation timers and 32 programmable logic points eliminate external timers and wiring for custom protection or control schemes. Each timer has independent time-delay pickup and dropout settings. Program each timer input with any desired element (e.g., time-qualify a voltage element). Assign the timer or logic point output to trip logic, reclose logic, or other control scheme logic.

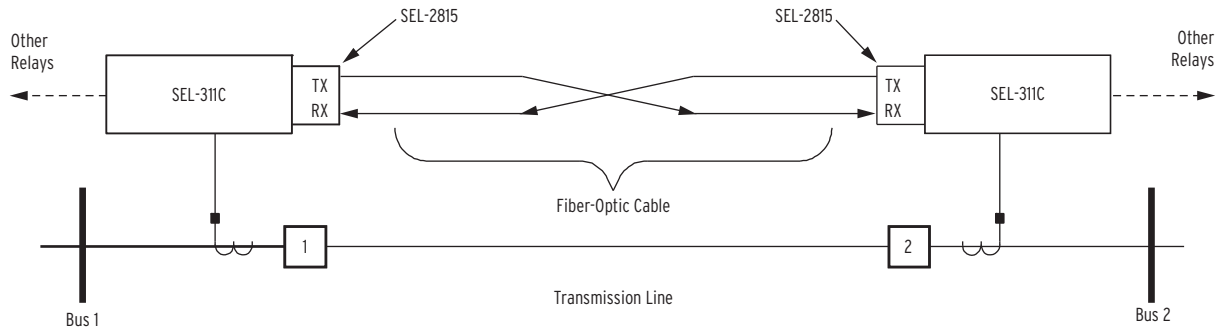

Figure 23 Integral Communications Provide Secure Protection, Monitoring, and Control

Six Independent Setting Groups Increase Operation Flexibility

The relay stores six setting groups. Select the active setting group by contact input, command, or other programmable conditions. Use these setting groups to cover a wide range of protection and control contingencies. Selectable setting

groups make the SEL-311C ideal for applications requiring frequent setting changes and for adapting the protection to changing system conditions.

Selecting a group also selects logic settings. Program group selection logic to adjust settings for different operating conditions, such as station maintenance, seasonal operations, emergency contingencies, loading, source changes, and adjacent relay setting changes.

Additional Features

Front-Panel User Interface

A close-up view of the user interface portion of the SEL-311C front panel is shown in *Figure 25*. It includes a two-line, 16-character LCD, 16 LED target indicators, and 8 pushbuttons for local communication.

Front-Panel Display

The LCD shows event, metering, setting, and relay self-test status information. The display is controlled with the eight multifunction pushbuttons. The target LEDs display relay target information as described in *Table 4*.

The LCD is controlled by the pushbuttons, automatic messages the relay generates, and user-programmed display points. The default display scrolls through any active, nonblank display points. If none are active, the relay displays the A-, B-, and C-phase currents in primary quantities. Each display remains for five seconds, before scrolling continues. Any message generated by the relay due to an alarm condition takes precedence over the normal default display. The EXIT pushbutton returns the display to the default display.

Error messages such as self-test failures are displayed on the LCD in place of the default display.

During power up the current will be displayed until the relay is enabled. When the EN LED indicates the relay is enabled, the active display points will be scrolled.

Status and Trip Target LEDs

The SEL-311C includes 16 status and trip target LEDs on the front panel. These targets are shown in *Figure 24* and explained in *Table 4*.

EN	TRIP	TIME	COMM	SOTF	RECLOSER		51
○	○	○	○	○	RS	LO	○
○	○	○	○	○	○	○	○
A	B	C	G	1	2	3	4
FAULT TYPE				ZONE/LEVEL			

Figure 24 Status and Trip Target LEDs

When the SEL-311C is ordered with programmable operator controls and target LEDs, many of the targets shown in *Figure 24* can be individually programmed for custom operation as trip targets or indicating lights. Program only the targets needed, and maintain factory-default target operation for the remainder.

Table 4 Description of LEDs (Sheet 1 of 2)

Target LED	Function
EN (fixed logic)	Relay powered properly and self-tests okay
TRIP	Indication that a trip occurred
TIME	Time-delayed trip
COMM	Communications-assisted trip
SOTF	Switch-onto-fault trip
RECLOSER	
RS	Ready for reclose cycle
LO	Control in lockout state
51	Time-overcurrent element trip
FAULT TYPE (fixed logic)	
A, B, C	Phases involved in fault
G	Ground involved in fault

Table 4 Description of LEDs (Sheet 2 of 2)

Target LED	Function
ZONE/LEVEL 1-4	Trip by Zone 1–4 distance elements and/or Level 1–4 overcurrent elements

Contact Inputs and Outputs

The base model SEL-311C includes eight output contacts and six optoisolated inputs. Additional outputs and inputs are available by adding an I/O board. Assign the contact inputs for control functions, monitoring logic, and general indication. Except for a dedicated alarm output, each contact output is programmable using SELOGIC control equations.

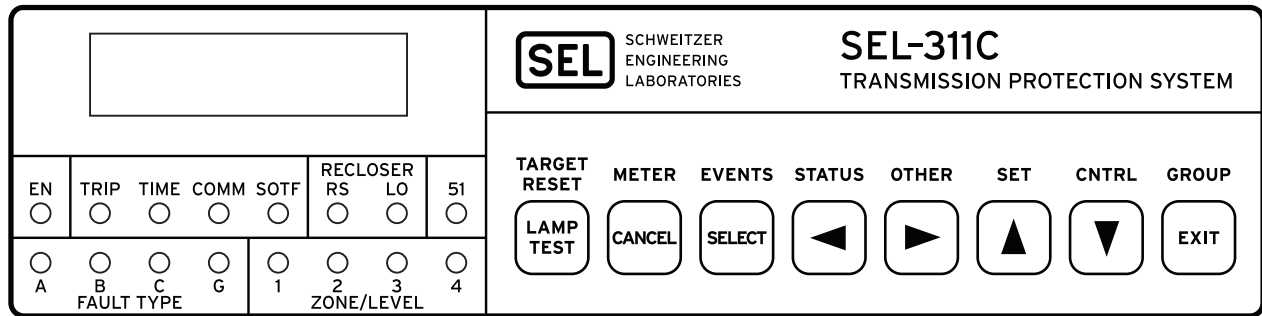

Figure 25 Status and Trip Target LEDs, Front-Panel Display, and Pushbuttons

Communications-Assisted Tripping Schemes

The SEL-311C is the ideal relay for use in transmission pilot-based tripping schemes. Schemes supported include:

- Permissive Overreaching Transfer Tripping (POTT) for two- or three-terminal lines.
- Directional Comparison Unblocking (DCUB) for two- or three-terminal lines.
- Directional Comparison Blocking (DCB).
- Permissive and Direct Underreaching Transfer Trip (PUTT and DUTT, respectively).
- Direct Transfer Tripping (DTT).

Use the SELOGIC control equation TRCOMM to program specific elements, combinations of elements, inputs, etc., to perform communication scheme tripping and other scheme functions. The communication logic of this relay easily handles the following challenges:

- Current reversals.
- Breaker open at one terminal.
- Weak-infeed conditions at one terminal.
- Switch-onto-fault conditions.

Time-step distance and time-overcurrent protection provide reliable backup operation should the channel be lost.

Wiring Diagram

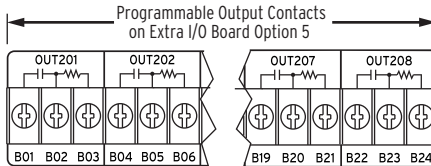
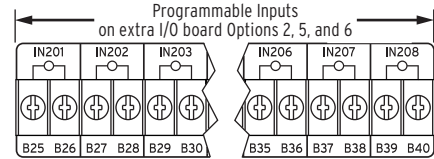
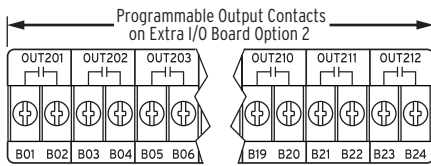
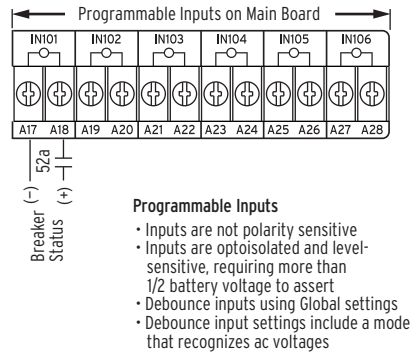
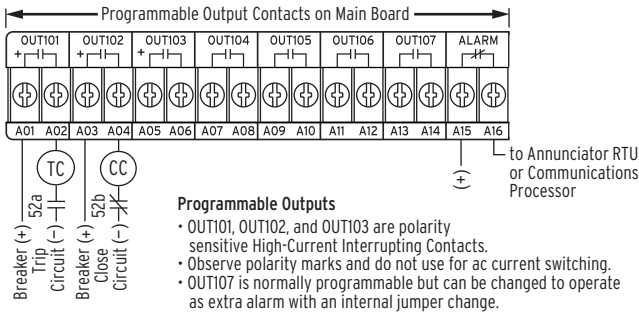

For specialized applications with sensitive auxiliary relays or digital inputs, connect the OUT201-OUT208 third terminal to provide a path for charging the circuit capacitance.

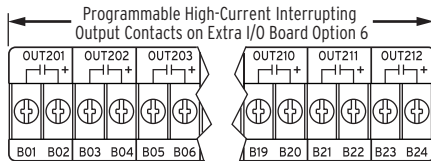

OUT201 to OUT212 are polarity sensitive High-Current Interrupting Contacts. Observe polarity marks and do not use for ac current switching.

Extra I/O Board Option 4 (Four standard outputs, sixteen programmable inputs) not shown.

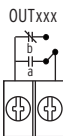

All main board and optional standard and high-current interrupting I/O board output contacts (OUT1xx and OUT2xx) are internally solder-jumper selectable for Form A or Form B configuration. On the high-speed, high current interrupting output board option 5, only OUT208 is solder-jumper selectable for Form A or Form B operation. All inputs, outputs and analog connections use screw terminals.

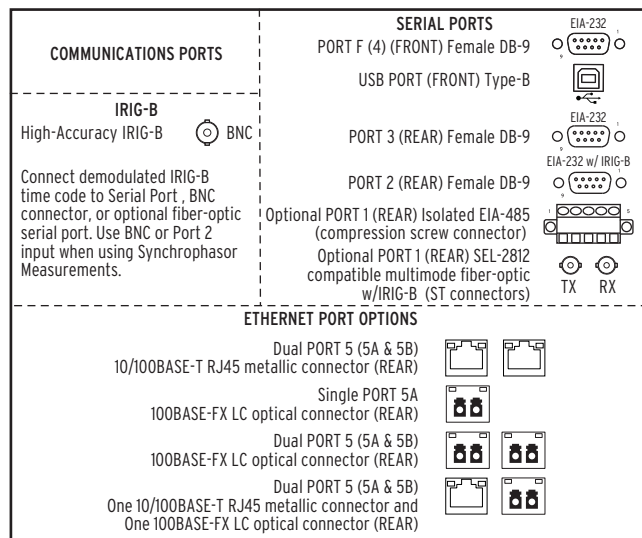

Figure 26 Example SEL-311C Wiring Diagram (Wye-Connected PTs; Synchronism-Check Voltage Input) (1 of 2)

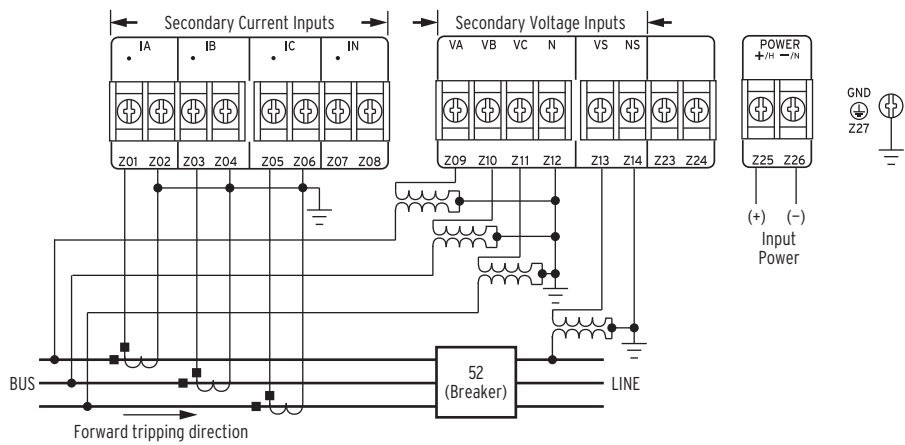
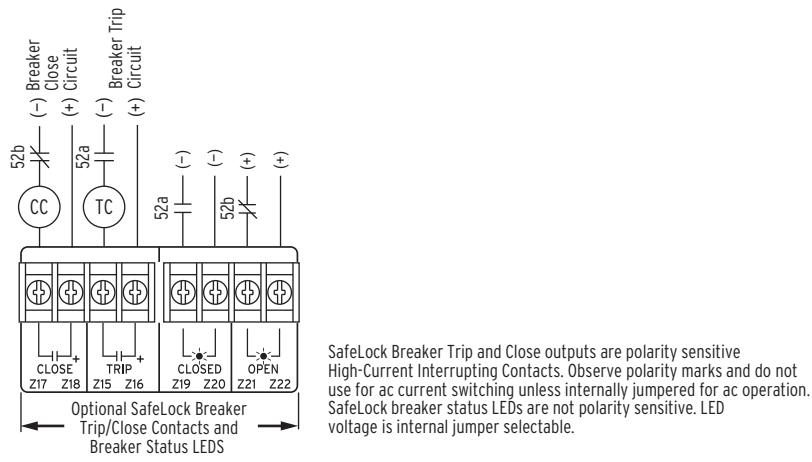

Figure 26 Example SEL-311C Wiring Diagram (Wye-Connected PTs; Synchronism-Check Voltage Input) (2 of 2)

Mechanical Diagrams

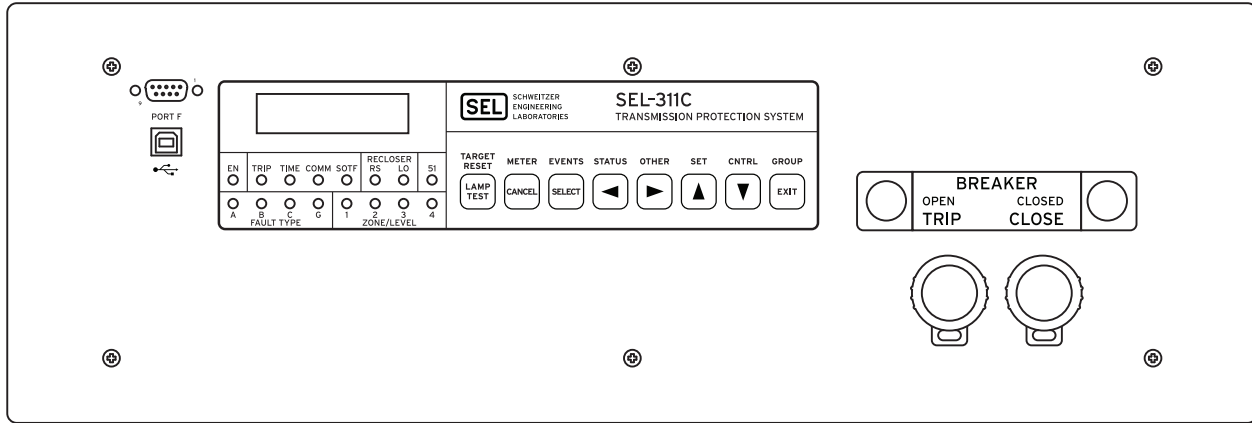
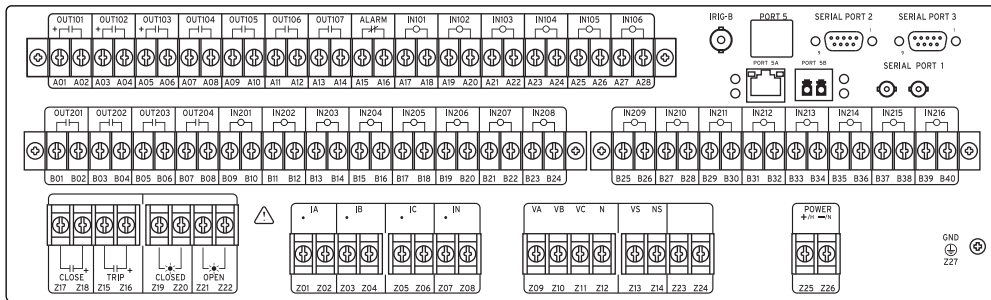

Figure 27 SEL-311C Horizontal Front-Panel Drawing (3U)

15064a



With Optional SafeLock Trip/Close Pushbuttons and Extra I/O Board Option 4

18083a

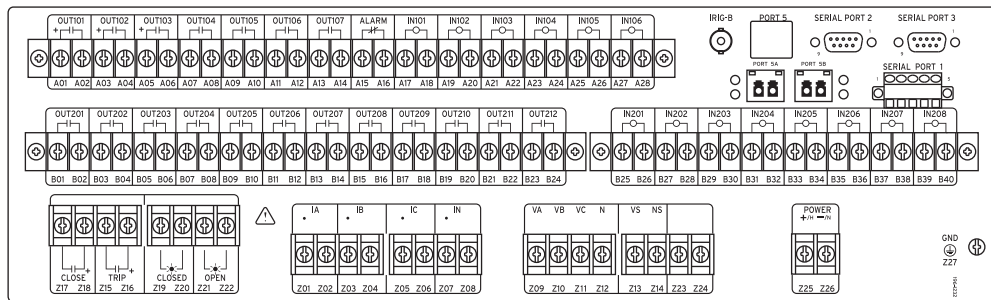

With Optional Extra I/O Board (Option 2 With Standard I/O Contacts Shown, Also Available With Option 6 High-Current Interrupting Contacts, Polarity Marks Not Shown) and Optional SafeLock Trip/Close Pushbuttons

14375b

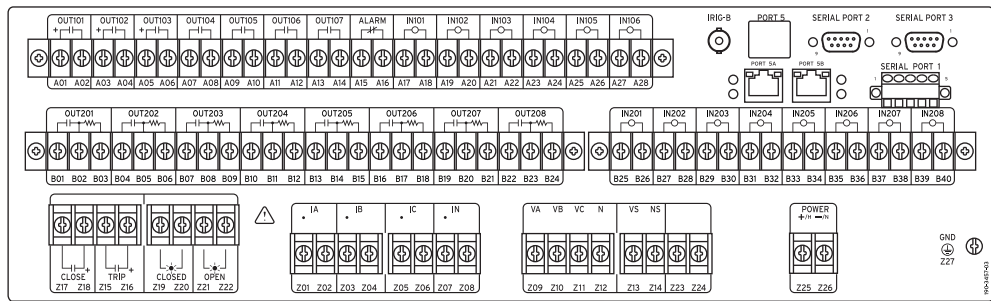

With Optional Extra I/O Board (Option 5 With High-Speed, High-Current Interrupting Contacts) and Optional SafeLock Trip/Close Pushbuttons

15088a

Vertical mount is identical to horizontal mount configuration rotated by 90 degrees counterclockwise.

Figure 28 SEL-311C Rear-Panel Drawings (3U) (Refer to Figure 29 for Communications Port Configurations)

Rear-Panel Communications Port Options

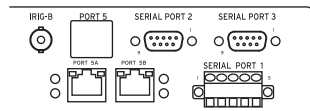

Dual-redundant 10/100BASE-T metallic Ethernet ports (5A and 5B) with EIA-485 serial Port 1

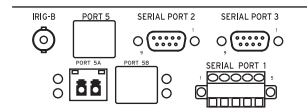

Single 100BASE-FX fiber Ethernet port (5A) with EIA-485 serial Port 1

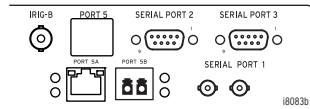

Dual-redundant 10/100BASE-T metallic and 100BASE-FX Ethernet ports (5A and 5B) with fiber-optic serial Port 1

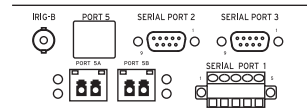

Dual-redundant 100BASE-FX Ethernet ports (5A and 5B) with EIA-485 serial Port 1

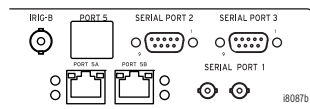

Dual-redundant 10/100BASE-T metallic Ethernet ports (5A and 5B) with fiber-optic serial Port 1

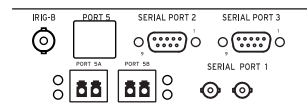

Dual-redundant 100BASE-FX Ethernet ports (5A and 5B) with fiber-optic serial Port 1

Figure 29 SEL-311C Rear-Panel Communications Port Configurations

Relay Mounting

PANEL-MOUNT CHASSIS

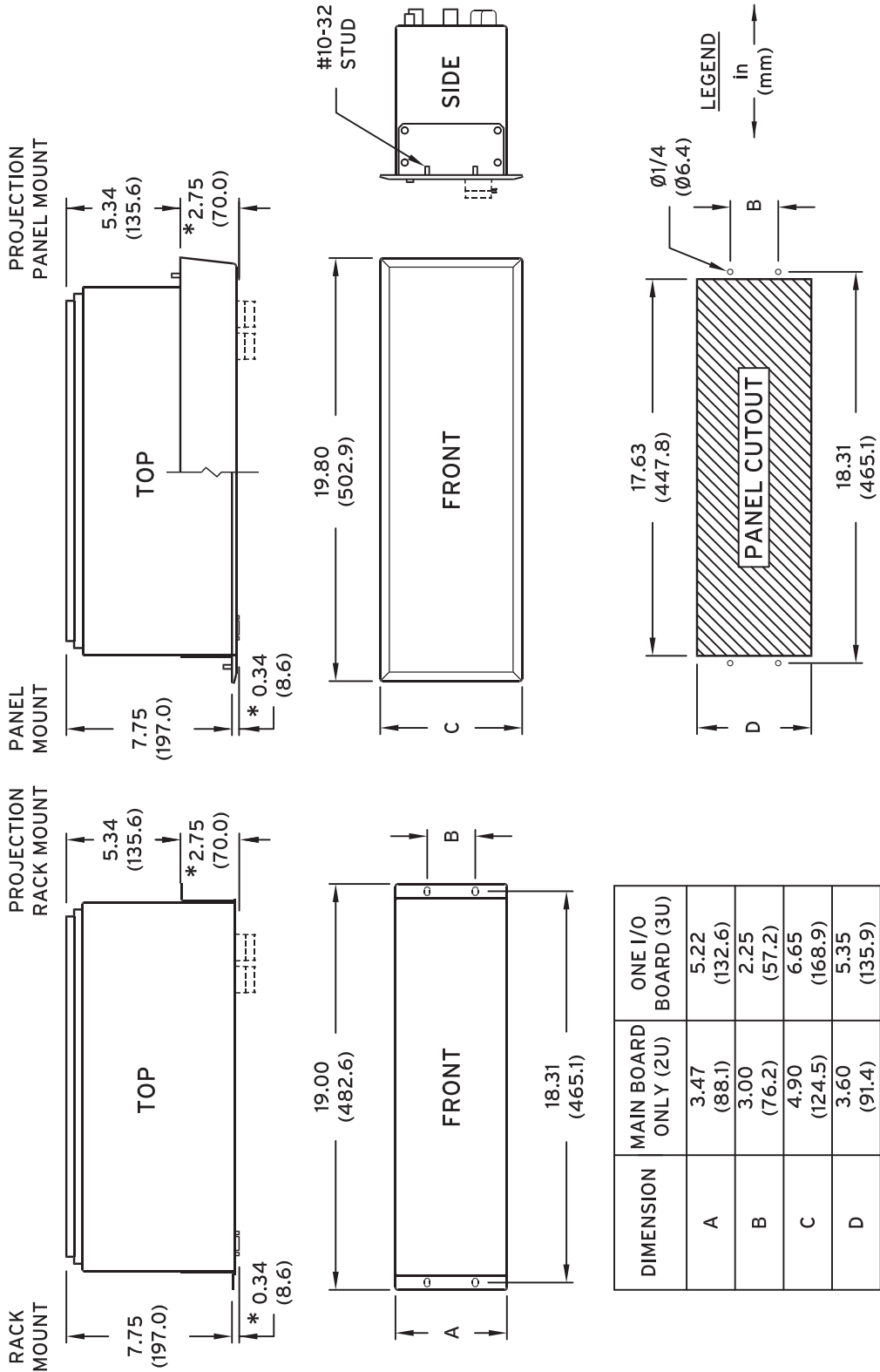

19169b

Figure 30 SEL-311C Dimensions and Drill Plan for Rack-Mount and Panel-Mount Models

Specifications

Important: Do not use the following information to order an SEL-311C. Refer to the actual ordering information sheets.

Compliance

Designed and manufactured under an ISO 9001 certified quality management system
 UL Listed to US and Canadian safety standards (File E212775; NRGU, NRGU7)
 CE Mark
 RCM Mark

General

Terminal Connections

Note: Terminals or stranded copper wire. Ring terminals are recommended. Minimum temperature rating of 75°C (167°F).

Tightening Torque

Terminals A01–A28
 Terminals B01–B40
 (if present): 1.1–1.3 Nm (9–12 in-lb)
 Terminals Z01–Z27: 1.1–1.3 Nm (9–12 in-lb)
 Serial Port 1
 (EIA-485, if present): 0.6–0.8 Nm (5–7 in-lb)

AC Voltage Inputs

Nominal Range
 Line to Neutral: 67–120 Vrms
 Line to Line
 (open delta): 115–260 Vrms
 Continuous: 300 Vrms
 250 Vrms (UL)
 Short-Term Overvoltage: 600 Vac for 10 seconds
 Burden: 0.03 VA @ 67 V; 0.06 VA @ 120 V;
 0.8 VA @ 300 V

AC Current Inputs

IA, IB, IC, and Neutral Channel IN

5 A Nominal: 15 A continuous, 500 A for 1 s,
 linear to 100 A symmetrical,
 1250 A for 1 cycle
 Burden: 0.27 VA @ 5 A, 2.51 VA @ 15 A
 1 A Nominal: 3 A continuous, 100 A for 1 s,
 linear to 20 A symmetrical,
 250 A for 1 cycle
 Burden: 0.13 VA @ 1 A, 1.31 VA @ 3 A

Power Supply

Rated: 125/250 Vdc nominal or 120/230 Vac
 nominal
 Range: 85–350 Vdc or 85–264 Vac
 Burden: <25 W
 Rated: 48/125 Vdc nominal or 120 Vac nominal
 Range: 38–200 Vdc or 85–140 Vac
 Burden: <25 W
 Rated: 24/48 Vdc nominal
 Range: 18–60 Vdc polarity dependent
 Burden: <25 W

Frequency and Rotation

Note: 60/50 Hz system frequency and ABC/ACB phase rotation are user-settable.

Frequency 40.1–65 Hz
 Tracking Range: (V_A or I_1 [positive-sequence current]
 required for frequency tracking; tracking
 switches to I_1 if $V_A < 10$ V).

Output Contacts

Standard

DC Output Ratings

Make: 30 A
 Carry 6 A continuous carry at 70°C
 4 A continuous carry at 85°C
 1 s Rating: 50 A
 MOV Protected: 270 Vac/360 Vdc/75 J
 Pickup Time: Less than 5 ms
 Dropout Time: Less than 5 ms, typical

Breaking Capacity (10,000 operations):

24 V	0.75 A	L/R = 40 ms
48 V	0.50 A	L/R = 40 ms
125 V	0.30 A	L/R = 40 ms
250 V	0.20 A	L/R = 40 ms

Cyclic Capacity (2.5 cycle/second):

24 V	0.75 A	L/R = 40 ms
48 V	0.50 A	L/R = 40 ms
125 V	0.30 A	L/R = 40 ms
250 V	0.20 A	L/R = 40 ms

Note: Make per IEEE C37.90-1989.

Note: Breaking and Cyclic Capacity per IEC 60255-0-20:1974.

Note: EA certified relays do not have MOV protected standard output contacts.

AC Output Ratings

Maximum Operational

Voltage (U_e) Rating: 240 Vac

Insulation Voltage (U_i)

Rating (Excluding
 EN 61010-1): 300 Vac

Utilization Category: AC-15 (control of electromagnetic
 loads > 72 VA)

Contact Rating

Designation: B300 (B = 5 A, 300 = rated insulation
 voltage)

Voltage Protection

Across Open
 Contacts: 270 Vac, 40 J

Rated Operational

Current (I_c): 3 A @ 120 Vac
 1.5 A @ 240 Vac

Conventional Enclosed

Thermal Current
 (I_{the}) Rating: 5 A

Rated Frequency: 50/60 ±5 Hz

Electrical Durability

Make VA Rating: 3600 VA, $\cos \phi = 0.3$

Electrical Durability

Break VA Rating: 360 VA, $\cos \phi = 0.3$

High-Current Interruption for OUT101, OUT102, OUT103, and Extra I/O Board

Make: 30 A

Carry 6 A continuous carry at 70°C
 4 A continuous carry at 85°C

1 s Rating: 50 A

MOV Protection: 330 Vdc/145 J

Pickup Time: Less than 5 ms

Dropout Time: Less than 8 ms, typical

Breaking Capacity (10,000 operations):

24 V	10 A	L/R = 40 ms
48 V	10 A	L/R = 40 ms
125 V	10 A	L/R = 40 ms
250 V	10 A	L/R = 20 ms

Cyclic Capacity (4 cycles in 1 second, followed by 2 minutes idle for thermal dissipation):

24 V	10 A	L/R = 40 ms
48 V	10 A	L/R = 40 ms
125 V	10 A	L/R = 40 ms
250 V	10 A	L/R = 20 ms

Note: Make per IEEE C37.90-1989.

Note: Do not use high-current interrupting output contacts to switch ac control signals. These outputs are polarity dependent.

Note: Breaking and Cyclic Capacity per IEC 60255-0-20:1974.

Fast Hybrid (High-Speed High-Current Interrupting) Option

Make:	30 A
Carry:	6 A continuous carry at 70°C 4 A continuous carry at 85°C
1 s Rating:	50 A
MOV Protection:	250 Vac / 330 Vdc / 145 J
Pickup Time:	Less than 200 µs
Dropout Time:	Less than 8 ms, typical

Breaking Capacity (10,000 operations):

24 V	10 A	L/R = 40 ms
48 V	10 A	L/R = 40 ms
125 V	10 A	L/R = 40 ms
250 V	10 A	L/R = 20 ms

Cyclic Capacity (4 cycles in 1 second, followed by 2 minutes idle for thermal dissipation):

24 V	10 A	L/R = 40 ms
48 V	10 A	L/R = 40 ms
125 V	10 A	L/R = 40 ms
250 V	10 A	L/R = 20 ms

Note: Make per IEEE C37.90-1989.

Note: Breaking and Cyclic Capacity per IEC 60255-0-20:1974.

SafeLock® Trip/Close Pushbuttons

Resistive DC or AC Load With Arc Suppression Disabled

Make:	30 A
Carry:	6 A continuous carry
1 s Rating:	50 A
MOV Protection:	250 Vac/330 Vdc/130 J

Breaking Capacity (2000 operations):

48 V	0.50 A	L/R = 40 ms
125 V	0.30 A	L/R = 40 ms
250 V	0.20 A	L/R = 40 ms

Note: Make per IEEE C37.90-1989.

High-Interrupt DC Outputs With Arc Suppression Enabled

Make:	30 A
Carry:	6 A continuous carry
1 s Rating:	50 A
MOV Protection:	330 Vdc / 130 J

Breaking Capacity (2000 operations):

48 V	10 A	L/R = 40 ms
125 V	10 A	L/R = 40 ms
250 V	10 A	L/R = 20 ms

Note: Make per IEEE C37.90-1989.

Breaker Open/Closed LEDs

250 Vdc:	on for 150–300 Vdc;	192–288 Vac
125 Vdc:	on for 80–150 Vdc;	96–144 Vac
48 Vdc:	on for 30–60 Vdc;	
24 Vdc:	on for 15–30 Vdc	

Note: With nominal control voltage applied, each LED draws 8 mA (max.). Jumpers may be set to 125 Vdc for 110 Vdc input and set to 250 Vdc for 220 Vdc input.

Optoisolated Input Ratings

When Used With DC Control Signals

250 Vdc:	on for 200–300 Vdc;	off below 150 Vdc
220 Vdc:	on for 176–264 Vdc;	off below 132 Vdc
125 Vdc:	on for 105–150 Vdc;	off below 75 Vdc
110 Vdc:	on for 88–132 Vdc;	off below 66 Vdc
48 Vdc:	on for 38.4–60 Vdc;	off below 28.8 Vdc
24 Vdc:	on for 15–30 Vdc	

When Used With AC Control Signals

250 Vdc:	on for 170.6–300 Vac;	off below 106.0 Vac
220 Vdc:	on for 150.3–264.0 Vac;	off below 93.2 Vac
125 Vdc:	on for 89.6–150.0 Vac;	off below 53.0 Vac
110 Vdc:	on for 75.1–132.0 Vac;	off below 46.6 Vac
48 Vdc:	on for 32.8–60.0 Vac;	off below 20.3 Vac
24 Vdc:	on for 12.8–30.0 Vac	

Note: AC mode is selectable for each input via Global settings IN101D–IN106D and IN201D–IN216D. AC input recognition delay from time of switching: 0.75 cycles maximum pickup, 1.25 cycles maximum dropout.

Note: All optoisolated inputs draw less than 10 mA of current at nominal voltage or ac rms equivalent.

Time-Code Inputs

Relay accepts demodulated IRIG-B time-code input at Port 2, at the rear-panel BNC input, or through the optional SEL-2812-compatible fiber-optic serial port.

Port 2, Pin 4 Input Current: 1.8 mA typical at 4.5 V (2.5 kΩ resistive)

BNC Input Current: 4 mA typical at 4.5 V (750 Ω resistive when input voltage is greater than 2 V)

Synchronization Accuracy

Internal Clock: ±1 µs

Synchrophasor Reports

(e.g., **MET PM**,
EVE P, **CEV P**): ±10 µs

All Other Reports: ±5 ms

Simple Network Time Protocol (SNTP) Accuracy

Internal Clock: ±5 ms

Unsynchronized Clock Drift

Relay Powered: 2 minutes per year typical

Communications Ports

EIA-232: 1 front, 2 rear

EIA-485: 1 rear with 2100 Vdc of isolation, optional

Fiber-Optic Serial Port: SEL-2812-compatible port, optional

Wavelength: 820 nm

Optical Connector Type: ST

Fiber Type: Multimode

Typical TX Power: –16 dBm

RX Min. Sensitivity: –24 dBm

Fiber Size: 62.5/125 µm

Per Port Data Rate Selections: 300, 1200, 2400, 4800, 9600, 19200, 38400, 57600

USB: 1 front (Type-B connector, CDC class device)

Ethernet: 2 standard 10/100BASE-T rear ports (RJ45 connector)
1 or 2 100BASE-FX rear ports optional (LC connectors)
Internal Ethernet switch included with second Ethernet port.

Dimensions

Refer to *Figure 30*.

Weight

11 lb (5.0 kg)—2U rack unit height relay

15 lb (6.8 kg)—3U rack unit height relay

Operating Temperature

−40° to +185°F (−40° to +85°C)

(LCD contrast impaired for temperatures below −20°C.)

Note: Temperature range is not applicable to UL-compliant installations.

Type Tests

Environmental Tests

Cold:	IEC 60068-2-1:2007 Environmental testing procedures, Part 2-1: Tests – Test Ad: Cold
Damp Heat, Cyclic:	IEC 60068-2-30:2005 Basic environmental testing procedures, Part 2-30: Tests, Test Db and guidance: Damp heat, cyclic (12 + 12-hour cycle), (six-day type test)
Dry Heat:	IEC 60068-2-2:2007 Environmental testing procedures, Part 2-2: Tests—Test Bd: Dry Heat
Environment:	IEC 60529:2001 + CRDG:2003 Degrees of Protection Provided by Enclosures (IP code): Object penetration and dust ingress, IP30 for category 2 equipment. For use in a Pollution Degree 2 environment

Routine Dielectric and Impulse Tests

Current Inputs, Optoisolated Inputs, and Output Contacts:	2500 Vac for 10 s
Power Supply:	3100 Vdc for 10 s IEC 60255-5 Dielectric Tests: 2000 2500 Vac for 1 minute on analog inputs, optoisolated inputs, and output contacts 3100 Vdc for 1 minute on power supply
Impulse:	IEC 60255-5:2000 Electrical relays, Part 5: Insulation tests for electrical relays. Section 6.1.3: Impulse Voltage Tests, 0.5 Joule 5 kV

Electromagnetic Compatibility (EMC)

Conducted Emissions:	IEC 60255-25:2000 Class A
Radiated Emissions:	IEC 60255-25:2000 Class A

RFI and Interference Tests

Fast Transient Disturbance:	IEC 60255-22-4:2008 Electrical disturbance tests for measuring relays and protection equipment, Section 4: Fast transient disturbance test, Severity Level: Class A 4 kV, 5 kHz on analog and power supply inputs 2 kV, 5 kHz on communications ports, digital inputs, and digital outputs
Radiated EMI:	IEC 60255-22-3:2007 Electrical relays, Section 3: Radiated electromagnetic field disturbance tests, Severity Level 3 (10 V/m) IEEE C37.90.2-2004, Standard for Withstand Capability of Relay Systems to Radiated Electromagnetic Interference from Transceivers, 35 V/m.

Surge Withstand:	IEC 60255-22-1:2007 Electrical disturbance tests for measuring relays and protection equipment, Part 22-1: 1 MHz burst disturbance tests. Severity Level 3 (2.5 kV common mode, 2.5 kV differential) IEEE C37.90.1-2002 2.5 kV oscillatory; 4.0 kV fast transient
ESD:	IEC 60255-22-2:2008 Electrical disturbance tests for measuring relays and protective equipment, Electrostatic discharge tests, Severity Level 4 (8 kV contact discharge all points except serial ports, 15 kV air discharge to all other points)

Vibration and Shock Tests

Shock and Bump:	IEC 60255-21-2:1988 Electrical relays, Part 21: Vibration, shock, bump, and seismic tests on measuring relays and protection equipment, Section Two: Shock and bump tests, Class 1 IEC 60255-21-3:1993 Electrical relays, Part 21: Vibration, shock, bump, and seismic tests on measuring relays and protection equipment, Section Three: Seismic tests, Class 2
Sinusoidal Vibration:	IEC 60255-21-1:1988 Electrical relays, Part 21: Vibration, shock, bump, and seismic tests on measuring relays and protection equipment, Section One: Vibration tests (sinusoidal), Class 1

Processing Specifications and Oscillography

AC Voltage and Current Inputs

128 samples per power system cycle, 3 dB low-pass filter cut-off frequency of 3 kHz

Digital Filtering

Digital low-pass filter then decimate to 32 samples per cycle followed by one-cycle cosine filter.
Net filtering (analog plus digital) rejects dc and all harmonics greater than the fundamental.

Protection and Control Processing

4 times per power system cycle

Oscillography

Length:	15, 30, 60, or 180 cycles
Total Storage:	12 seconds of analog and binary
Sampling Rate:	128 samples per cycle unfiltered 32 and 16 samples per cycle unfiltered and filtered 4 samples per cycle filtered
Trigger:	Programmable with Boolean expression
Format:	ASCII and Compressed ASCII Binary COMTRADE (128 samples per cycle unfiltered)
Time-Stamp Resolution:	1 μ s when high-accuracy time source is connected (EVE P or CEV P commands). 1 ms otherwise.
Time-Stamp Accuracy:	See <i>Time-Code Inputs</i> on page 1.3 in the instruction manual.

Sequential Events Recorder

Time-Stamp Resolution:	1 ms
Time-Stamp Accuracy (with respect to time source):	± 5 ms

Relay Element Pickup Ranges and Accuracies

Mho Phase Distance Elements

Zones 1-4 Impedance Reach

Setting Range:	OFF, 0.05 to 64 Ω sec, 0.01 Ω steps (5 A nominal) OFF, 0.25 to 320 Ω sec, 0.01 Ω steps (1 A nominal) Minimum sensitivity is controlled by the pickup of the supervising phase-to-phase overcurrent elements for each zone.
Accuracy:	$\pm 5\%$ of setting at line angle for $30 \leq \text{SIR} \leq 60$ $\pm 3\%$ of setting at line angle for $\text{SIR} < 30$
Transient Overreach:	$< 5\%$ of setting plus steady-state accuracy

Zones 1-4 Phase-to-Phase Current Fault Detectors (FD)

Setting Range:	0.5–170.00 $A_{p,p}$ secondary, 0.01 A steps (5 A nominal) 0.1–34.00 $A_{p,p}$ secondary, 0.01 A steps (1 A nominal)
Accuracy:	± 0.05 A and $\pm 3\%$ of setting (5 A nominal) ± 0.01 A and $\pm 3\%$ of setting (1 A nominal)
Transient Overreach:	$< 5\%$ of pickup
Max. Operating Time:	See <i>Figure 3.13–Figure 3.16</i> in the instruction manual.

Mho and Quadrilateral Ground Distance Element

Zones 1-4 Impedance Reach

Mho Element Reach:	OFF, 0.05 to 64 Ω sec, 0.01 Ω steps (5 A nominal) OFF, 0.25 to 320 Ω sec, 0.01 Ω steps (1 A nominal)
Quadrilateral Reactance Reach:	OFF, 0.05 to 64 Ω sec, 0.01 Ω steps (5 A nominal) OFF, 0.25 to 320 Ω sec, 0.01 Ω steps (1 A nominal)
Quadrilateral Resistance Reach:	OFF, 0.05 to 50 Ω sec, 0.01 Ω steps (5 A nominal) OFF, 0.25 to 250 Ω sec, 0.01 Ω steps (1 A nominal) Minimum sensitivity is controlled by the pickup of the supervising phase and residual overcurrent elements for each zone.
Accuracy:	$\pm 5\%$ of setting at line angle for $30 \leq \text{SIR} \leq 60$ $\pm 3\%$ of setting at line angle for $\text{SIR} < 30$
Line Angle:	$\geq 45^\circ$ (Quadrilateral)
Transient Overreach:	$< 5\%$ of setting plus steady-state accuracy

Zones 1-4 Phase and Residual Current Fault Detectors (FD)

Setting Range:	0.5–100.00 A secondary, 0.01 A steps (5 A nominal) 0.1–20.00 A secondary, 0.01 A steps (1 A nominal)
Accuracy:	± 0.05 A and $\pm 3\%$ of setting (5 A nominal) ± 0.01 A and $\pm 3\%$ of setting (1 A nominal)
Transient Overreach:	$< 5\%$ of pickup
Max. Operating Time:	See <i>Figure 3.17–Figure 3.20</i> in the instruction manual.

Instantaneous/Definite-Time Overcurrent Elements

Pickup Range:	0.25–100.00 A, 0.01 A steps (5 A nominal) 0.050–100.000 A, 0.010 A steps (5 A nominal—for residual ground elements) 0.05–20.00 A, 0.01 A steps (1 A nominal) 0.010–20.000 A, 0.002 A steps (1 A nominal—for residual ground elements)
Steady-State Pickup Accuracy:	± 0.05 A and $\pm 3\%$ of setting (5 A nominal) ± 0.01 A and $\pm 3\%$ of setting (1 A nominal)
Transient Overreach:	$\pm 5\%$ of pickup
Time Delay:	0.00–16,000.00 cycles, 0.25 cycle steps
Timer Accuracy:	± 0.25 cycle and $\pm 0.1\%$ of setting

Note: See pickup and reset time curves in *Section 3: Distance, Out-of-Step, Overcurrent, Voltage, Synchronism Check, and Frequency Elements* in the instruction manual.

Breaker Failure Current Detectors and Logic

Pickup Range:	0.5–100.00 A, 0.01 A steps (5 A nominal) 0.1–20.00 A, 0.01 A steps (1 A nominal)
Steady-State Pickup Accuracy:	± 0.05 A and $\pm 3\%$ of setting (5 A nominal) ± 0.01 A and $\pm 3\%$ of setting (1 A nominal)
Transient Overreach:	$\pm 5\%$ of pickup
Reset Time:	≤ 1 cycle
Pickup Time:	≤ 1 cycle for current greater than 2 multiples of pickup
Time Delay:	0.00–6000.00 cycles, 0.25-cycle steps
Timer Accuracy:	± 0.25 cycle and $\pm 0.1\%$ of setting

Time-Overcurrent Elements

Pickup Range:	0.25–16.00 A, 0.01 A steps (5 A nominal) 0.10–16.00 A, 0.01 A steps (5 A nominal—for residual ground elements) 0.05–3.20 A, 0.01 A steps (1 A nominal) 0.02–3.20 A, 0.01 A steps (1 A nominal—for residual ground elements)
Steady-State Pickup Accuracy:	± 0.05 A and $\pm 3\%$ of setting (5 A nominal) ± 0.01 A and $\pm 3\%$ of setting (1 A nominal)
Time-Dial Range:	0.50–15.00, 0.01 steps (U.S.) 0.05–1.00, 0.01 steps (IEC)
Curve Timing Accuracy:	± 1.50 cycles and $\pm 4\%$ of curve time for current between 2 and 30 multiples of pickup ± 1.50 cycles and $\pm 4\%$ of curve time for current less than 1 multiple of pickup

Out-of-Step Elements

Blinders (R1) Parallel to the Line Angle:	0.05 to 70 Ω secondary –0.05 to –70 Ω secondary (5 A nominal) 0.25 to 350 Ω secondary –0.25 to –350 Ω secondary (1 A nominal)
Blinders (X1) Perpendicular to the Line Angle:	0.05 to 96 Ω secondary –0.05 to –96 Ω secondary (5 A nominal) 0.25 to 480 Ω secondary –0.25 to –480 Ω secondary (1 A nominal)

Accuracy (Steady State): $\pm 5\%$ of setting plus ± 0.01 A for SIR (source to line impedance ratio) < 30
 $\pm 10\%$ of setting plus ± 0.01 A for $30 \leq \text{SIR} \leq 60$ (5 A nominal)
 $\pm 5\%$ of setting plus ± 0.05 A for SIR (source to line impedance ratio) < 30
 10% of setting plus ± 0.05 A for $30 \leq \text{SIR} \leq 60$ (1 A Nominal)

Transient Overreach: $< 5\%$ of setting plus steady-state accuracy

Positive-Sequence Overcurrent Supervision

Setting Range 1.0–100.0 A, 0.01 A steps (5 A nominal)
 0.2–20.0 A, 0.01 A steps (1 A nominal)
 Accuracy $\pm 3\%$ of setting plus ± 0.05 A (5 A nominal)
 $\pm 3\%$ of setting plus ± 0.01 A (1 A nominal)

Transient Overreach: $< 5\%$ of setting

Under- and Overvoltage Elements

Pickup Ranges

Wye-Connected (Global setting PTCO = WYE): 0.00–200.00 V, 0.01 V steps (negative-sequence element)
 0.00–300.00 V, 0.01 V or 0.02 V steps (various elements)
 0.00–520.00 V, 0.02 V steps (phase-to-phase elements)
 Open-Delta Connected (when available, by Global setting PTCO = DELTA): 0.00–120.00 V, 0.01 V steps (negative-sequence elements)
 0.00–170.00 V, 0.01 V steps (positive-sequence element)
 0.00–300.00 V, 0.01 V steps (various elements)
 Steady-State Pickup Accuracy: ± 0.5 V plus $\pm 1\%$ for 12.5–300.00 V (phase and synchronizing elements)
 ± 0.5 V plus $\pm 2\%$ for 12.5–300.00 V (negative-, positive-, and zero-sequence elements, phase-to-phase elements)

Transient Overreach: $\pm 5\%$ of pickup

Synchronism-Check Elements

Slip Frequency Pickup Range: 0.005–0.500 Hz, 0.001 Hz steps
 Slip Frequency Pickup Accuracy: ± 0.003 Hz
 Phase Angle Range: 0–80°, 1° steps
 Phase Angle Accuracy: $\pm 4^\circ$

Under- and Overfrequency Elements

Pickup Range: 40.10–65.00 Hz, 0.01 Hz steps
 Steady-State plus Transient Overshoot: ± 0.01 Hz for 1 Hz step change
 Pickup/Dropout Time: Maximum instantaneous element response time to a step change in frequency (dF)

NFREQ = 50 Hz NFREQ = 60 Hz

$|81\text{DnP-Initial Freq}| \leq 0.5 |dF|$ 80 ms 67 ms
 $|81\text{DnP-Initial Freq}| > 0.5 |dF|$ 120 ms 100 ms

Time Delay: 2.00–16,000.00 cycles, 0.25-cycle steps
 Timer Accuracy: ± 0.25 cycle and $\pm 0.1\%$ of setting
 Undervoltage Frequency Element Block Range: 20.00–300.00 V_{LN} (wye) or V_{LL} (open-delta)

Timers

Pickup Ranges: 0.00–999,999.00 cycles, 0.25-cycle steps (reclosing relay and some programmable timers)
 0.00–16,000.00 cycles, 0.25-cycle steps (some programmable and other various timers)

Pickup and Dropout Accuracy for all Timers: ± 0.25 cycle and $\pm 0.1\%$ of setting

Substation Battery Voltage Monitor

Pickup Range: 20–300 Vdc, 0.02 Vdc steps
 Pickup accuracy: $\pm 2\%$ of setting ± 2 Vdc

Fundamental Metering Accuracy

Accuracies are specified at 20°C, at nominal system frequency, and voltage 67–250 V unless noted otherwise.

V_A, V_B, V_C : $\pm 0.2\%$ (67.0–250 V; wye-connected)
 $\pm 0.4\%$ typical (250–300 V; wye-connected)
 V_{AB}, V_{BC}, V_{CA} : $\pm 0.4\%$ (67.0–250 V; delta-connected)
 $\pm 0.8\%$ typical (250–300 V; delta-connected)
 V_S : $\pm 0.2\%$ (67.0–250 V)
 $\pm 0.4\%$ typical (250–300 V)

$3V_0, V_1, V_2$ ($3V_0$ not available with delta-connected inputs): $\pm 0.6\%$ (67.0–250 V)
 $\pm 1.2\%$ typical (250–300 V)

I_A, I_B, I_C : ± 4 mA and $\pm 0.1\%$ (1.0–100 A) (5 A nominal)
 ± 6 mA and $\pm 0.1\%$ (0.25–1.0 A) (5 A nominal)
 ± 1 mA and $\pm 0.1\%$ (0.2–20 A) (1 A nominal)
 ± 2 mA and $\pm 0.1\%$ (0.05–0.2 A) (1 A nominal)
 Temperature coefficient: $[(0.0002\%)/(\text{°C})^2] \cdot (\text{°C} - 20\text{°C})^2$

I_N : ± 4 mA and $\pm 0.1\%$ (1.0–100 A) (5 A nominal)
 ± 6 mA and $\pm 0.1\%$ (0.25–1.0 A) (5 A nominal)
 ± 1 mA and $\pm 0.1\%$ (0.2–20 A) (1 A nominal)
 ± 2 mA and $\pm 0.1\%$ (0.05–0.2 A) (1 A nominal)
 Temperature coefficient: $[(0.0002\%)/(\text{°C})^2] \cdot (\text{°C} - 20\text{°C})^2$

$I_1, 3I_0, 3I_2$: ± 0.05 A and $\pm 3\%$ (0.5–100 A) (5 A nominal)
 ± 0.01 A and $\pm 3\%$ (0.1–20 A) (1 A nominal)

Phase Angle Accuracy

I_A, I_B, I_C
 5 A Nominal: $\pm 0.5^\circ$ (1.0–100 A)
 $\pm 3^\circ$ (0.25–1.0 A)
 1 A Nominal: $\pm 0.5^\circ$ (0.2–20 A)
 $\pm 5^\circ$ (0.05–0.2 A)

V_A, V_B, V_C, V_S : $\pm 0.5^\circ$
 V_{AB}, V_{BC}, V_{CA} : $\pm 1.0^\circ$

MW/MVAR (A, B, C, and three-phase; wye-connected voltages) MW/MVAR (three-phase; open-delta connected voltages; balanced conditions)	
Accuracy (MW/MVAR)	at load angle
for phase current $\geq 0.2 \cdot I_{NOM}$:	
0.35% / –	0° or 180° (unity power factor)
0.75% / 1.50%	$\pm 30^\circ$ or $\pm 150^\circ$
1.50% / 0.75%	$\pm 60^\circ$ or $\pm 120^\circ$
– / 0.35%	$\pm 90^\circ$ (power factor = 0)

Energy Meter

Accumulators:	Separate IN and OUT accumulators updated twice per second, transferred to non-volatile storage once per day.
ASCII Report Resolution:	0.01 MWh
Accuracy:	The accuracy of the energy meter depends on applied current and power factor as shown in the power metering accuracy table above. The additional error introduced by accumulating power to yield energy is negligible when power changes slowly compared to the processing rate of twice per second.

Synchrophasor Accuracy**Maximum Data Rate in Messages per Second**

IEEE C37.118 Protocol:	60 (nominal 60 Hz system) 50 (nominal 50 Hz system)
SEL Fast Message Protocol:	1
IEEE C37.118 Accuracy:	Level 1 at maximum message rate when phasor has the same frequency as A-phase voltage, frequency-based phasor compensation is enabled (PHCOMP = Y), and the narrow bandwidth filter is selected (PMAPP = N). Out-of-band interfering frequency (Fs) test, $10 \text{ Hz} \leq F_s \leq (2 \cdot \text{NFREQ})$.
Current Range:	$(0.1-2) \cdot I_{\text{NOM}}$ ($I_{\text{NOM}} = 1 \text{ A or } 5 \text{ A}$)
Frequency Range:	$\pm 5 \text{ Hz}$ of nominal (50 or 60 Hz)
Voltage Range:	30 V–250 V
Phase Angle Range:	-179.99° to 180°

Notes

© 2011-2017 by Schweitzer Engineering Laboratories, Inc. All rights reserved.

All brand or product names appearing in this document are the trademark or registered trademark of their respective holders. No SEL trademarks may be used without written permission. SEL products appearing in this document may be covered by U.S. and Foreign patents.

Schweitzer Engineering Laboratories, Inc. reserves all rights and benefits afforded under federal and international copyright and patent laws in its products, including without limitation software, firmware, and documentation.

The information in this document is provided for informational use only and is subject to change without notice. Schweitzer Engineering Laboratories, Inc. has approved only the English language document.

This product is covered by the standard SEL 10-year warranty. For warranty details, visit selinc.com or contact your customer service representative.

SCHWEITZER ENGINEERING LABORATORIES, INC.

2350 NE Hopkins Court • Pullman, WA 99163-5603 U.S.A.

Tel: +1.509.332.1890 • Fax: +1.509.332.7990

selinc.com • info@selinc.com



* P D S 3 1 1 C - 0 2 *